



Fire Products & Solutions

FA40 OPERATION MANUAL - Issue 0.5

firealert - **FA40**

Residential Controlling & Indicating Equipment (RCIE)



MA475

Dec 2025



Fire Products & Solutions

firealert

FA40 Operation Manual

FireAlert Smoke Alarm System Iss 0.5

This page has deliberately been left blank



Table of contents

Table of contents	3
1 SYSTEM OVERVIEW.....	7
1.1 System Features.....	8
1.2 Terms & Definitions	9
2 SYSTEM COMPONENTS	11
2.1 FireAlert Series Alarms (FA0xx).....	11
2.1.1 Smoke Alarm (FA016)	11
2.1.1.1 Overview Description	11
2.1.1.2 Features	12
2.1.1.3 Specifications	12
2.1.1.4 Operation.....	12
2.1.2 Heat Alarm (FA014).....	13
2.1.2.1 Overview Description	13
2.1.2.2 Features	13
2.1.2.3 Specifications	14
2.1.2.4 Operation.....	14
2.1.3 Multi-Sensor Alarm (FA024) ..COMING SOON.....	15
Overview description.....	15
2.1.3.2 Features	16
2.1.3.3 Specifications	16
2.1.3.4 Operation.....	16
2.2 Easi-fit FA Base (FA000).....	17
2.2.1 Overview Description	17
2.2.2 Head Configuration	18
2.2.3 Status Indicator	19
2.2.4 Reset Button	20
2.2.4.1 FA000 device address identification:	20
2.2.4.2 FA000 device Factory reset:	20
2.3 Residential Control and Indicating Equipment (FA40)	21
2.3.1 Overview Description	21
2.3.2 FA40 Main Control Board	23
2.3.2.1 Description	23
2.3.2.2 Board Connection	24
2.3.2.3 Ancillary Control Facility (ACF) output	26
2.3.2.4 Dip Switches Settings	27
2.3.3 FA40 User Interface Display Board	28
2.3.3.1 Description	28
2.3.3.2 Board Connection	29
2.3.4 The FA40 Power Supply	31
2.3.4.1 Description	31
2.3.4.2 Features	31
2.3.4.3 Specifications	32



2.3.4.4	DIP Switch Settings.....	33
2.3.4.5	Board Connection	34
3	INSTALLATION & COMMISSIONING.....	36
3.1	FA40 Cabinet Installation:	36
3.1.1	Electrical Safeguards	37
3.1.2	Cabinet Mounting	38
3.1.3	Battery Mounting	39
3.1.4	FA40 Battery Calculation	40
3.1.5	FA40 Wiring	40
3.1.5.1	Mains Wiring	40
3.1.5.2	Field Wiring	41
3.1.5.3	Zone Wiring	42
3.1.6	Adding Zone Descriptions	44
3.1.7	Zone block plan.....	45
3.2	FA000 Base Installation & Alarm Heads	46
3.2.1	Location.....	46
3.2.1.1	Smoke and Heat alarms.....	46
3.2.1.2	Locations to avoid (refer to AS1670.6 clause §3.2.3.7).....	47
3.2.2	Mounting	47
3.2.3	FA000 Wiring instructions	48
3.2.3.1	Cable Properties/Selection.....	49
3.2.3.2	Wiring from within the ceiling	49
3.2.3.3	Wiring along the surface of the ceiling (Surface ducting)	49
3.2.3.4	Mounting FA000.....	50
3.2.4	Connecting FA Alarms to the FA Base	51
3.2.5	Removing FA Alarms from the FA Base	52
3.3	FA40 System Setup.....	53
3.3.1	Initial system testing.....	53
3.3.2	Alarms Devices Set-up	54
3.3.2.1	Device Configuration.....	54
3.3.2.2	Alarm devices auto addressing sequence:	57
3.3.2.3	FA40 initial auto addressing trouble shooting guide:	57
3.3.3	FA40 Zone reconfiguration guidance:.....	58
3.3.3.1	Removing the end device from the zone:	58
3.3.3.2	Removing a device from the middle of the zone:.....	58
3.3.3.3	Adding a device to the end of the zone circuit:	59
3.3.3.4	Inserting a device into the middle of the zone:.....	59
4	FA40 OPERATION.....	61
4.1	ALARM TYPE	61
4.2	FA40 Controls.....	62
4.2.1	SILENCE BUZZER	62
4.2.2	LOCATE ALARM	62
4.2.3	SILENCE ALARM	63
4.2.4	ALARM RESET	63
4.2.4.1	FA40 UI Indicator test	63



4.2.5	ACF INHIBIT	64
4.2.6	ACCESS LEVEL	64
4.3	FAULTS	66
5	FUNCTIONAL TESTING	67
5.1	GENERAL	67
5.1.1	Pre-Testing.....	67
5.1.2	Zone Alarm Test:.....	68
5.1.3	Zone Fault Test:.....	68
5.1.4	Power Supply Test:.....	68
5.1.5	ACF Inhibit Function Test:	69
5.1.6	Fire Mode Test:	69
6	TROUBLE SHOOTING	71
6.1	FA Alarms	71
6.1.1.1	FA014, FA016, FA024 Indicator Summary	71
6.1.2	Low Battery Backup Fault	74
6.1.3	Sensor Fault.....	74
6.1.4	End of Life	74
6.1.5	Max Dust compensation	74
6.1.6	Temporarily Silencing the Fault chirps.....	74
7	MAINTENANCE	75
7.1	Cleaning alarms.....	75
7.2	Battery Maintenance.....	75
8	BLOCK WIRING DIAGRAM	76
9	GUARANTEE	77
10	REVISION HISTORY	78

Figure List

Figure 1:	FireAlert Smoke Alarm System	7
Figure 3:	FA016 Smoke Alarm	11
Figure 4:	FA014 Heat Alarm.	13
Figure 5:	FA024 Multi-Sensor Alarm (coming soon).....	15
Figure 6:	FA000	17
Figure 7:	FA000 Interface Board.....	18
Figure 8:	Pressing FA000 Reset button.....	20
Figure 9:	FA40 Main Control Board	23
Figure 10:	FA40 Main Control Board Connection	24
Figure 11:	FA40 User Interface Display Board	28
Figure 12:	FA40 User Interface Board Connection.....	30
Figure 13:	Power Supply Supervision Board.....	31
Figure 14:	Power Supply Supervision Board Connection	34
Figure 15:	Access to FA40's internals.	36
Figure 16:	FA40 Electrical Safeguards.....	37
Figure 17:	FA40 cabinet's mounting positions.....	38
Figure 18:	FA40 Battery Compartment.....	39
Figure 19:	FA40 designated Mains voltage connection	40



Figure 20: FA40 Zone wiring area41

Figure 21: Insertion of the Zone description Label44

Figure 22: Zone block diagram area45

Figure 23: FA000 Mounting Base Plastic46

Figure 24: Smoke Alarm locations inside a room46

Figure 25: Minimum mounting distance from other objects47

Figure 26: FA Alarms removal procedure52

Figure 27: FA000 Base DIP Switch55

Figure 28: 4 x SUB1055 inserted into each FA40 Zone.....55

Figure 29: SUB1055 – FA EOL Device.56

Figure 30: Zone 1 Reconfiguration Guidance.....58

Figure 31: FA40 Alarm Condition Controls62

Figure 32: Access level and ACF Inhibit Control64

Figure 33: FA40 Standard Block Wiring Diagram76

Tables List

Table 1 Dip Switch Settings of FA000 Base18

Table 2: FA000 Base DIP Switch Combinations.....19

Table 3: FA000 Base Fault Indicator19

Table 4: FA40 Specifications.....22

Table 5 FA40 Main Control Board Connection.....25

Table 6 “COM” Dip Switch Positions27

Table 7 Main Control Board Fuse Specifications.27

Table 8 Connection of FA40 User Interface Board29

Table 9 Power Supply Supervision Specifications.....32

Table 10 Power Supply Supervision DIP switch & configurations33

Table 11 Power Supply Supervision Fuse Specifications.....33

Table 12 Connection of the Power Supply Supervision Board34

Table 13 Power Supply Supervision LED indications and description-135

Table 14 Power Supply Supervision LED indications and description -235

Table 15: Electrical Safeguards.....37

Table 16: Zone wiring data example:43

Table 17: System Controls vs Access level65

Table 18 List of all faults and their descriptions of FA40 RCIE66

Table 19: FA014, FA016 & FA024 Indicator & Sound patterns71

Table 20: Memory Mode indicator and Sound patterns.....72

Table 21: Fault Mode and Memory Indicator73

1 SYSTEM OVERVIEW

The FireAlert smoke alarm system (SAS) has been designed to meet the specific requirement of AS1670.6 Fire Detection, Warning, Control and Intercom Systems – System Design, Installation and Commissioning Part 6 Smoke alarm systems and the National Construction Code (NCC) Specifications 20 and 23 for smoke alarm systems.

FireAlert utilises a data-over-power design enabling each FA base device to identify the type of alarm connected. This identification allows the FA40 to distinguish between different alarm types - currently supporting smoke, heat, multi-sensor (smoke/heat) alarms. The FA40 user interface displays the specific alarm type that has initiated the fire alarm through dedicated LED indicators. This critical feature allows occupants to understand the nature and location of the fire alarm, which in turn, identifies the urgency and the most appropriate exit strategy.

FireAlert provides the SAS designer with a full range of fire alarm devices (smoke, heat and multi-sensor) interfaced to Residential Control and Indicating Equipment (RCIE). This combination of RCIE and fire alarm devices provides the necessary design flexibility to enable a fit for purpose life safety solution within class 1a, class 1b boarding houses, class 2, class 3, class 4 & some class 9c residential building applications.

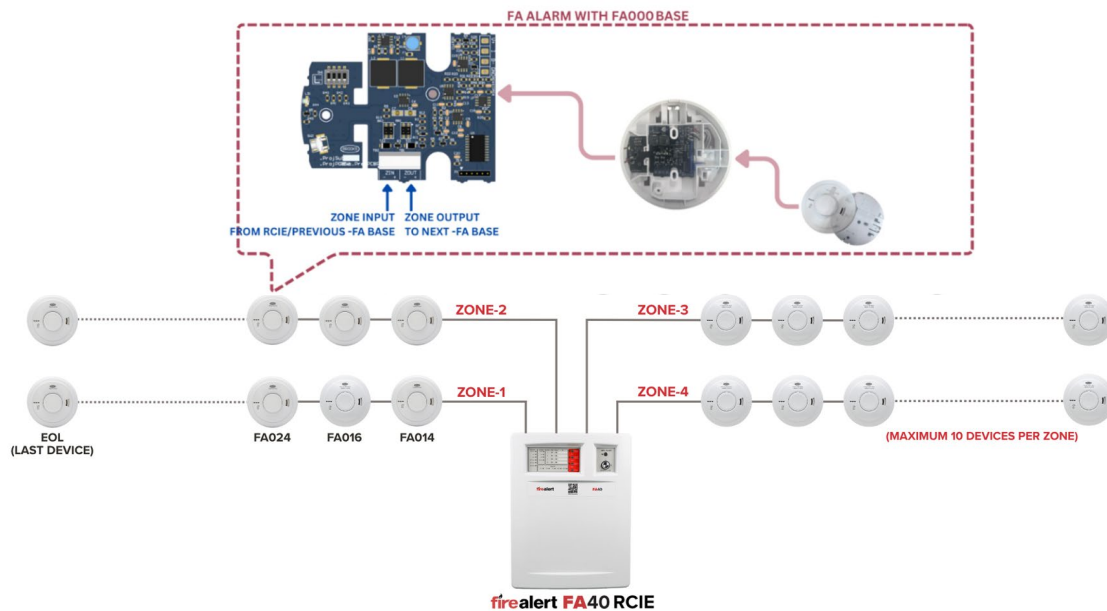

Figure 1: FireAlert Smoke Alarm System

Note: The FA40 RCIE cannot be expanded in either the number of zones or power supply output.



Fire Products & Solutions

firealert

FA40 Operation Manual

FireAlert Smoke Alarm System Iss 0.5

1.1 System Features

- Four zone circuits with up to 10 devices per zone (40 devices total)
- Device type identification for alarm priority with individual LED indicators for smoke, heat, multi-sensor
- Individual zone and common alarm/fault indication
- Comprehensive fault monitoring including open circuit, short circuit, earth fault, PSU fault, and device removal detection
- User-friendly controls: Silence Buzzer, Locate Alarm, Silence Alarm, and Reset functions
- Two-tier access control with key switch for user and technician levels
- ACF (Ancillary Control Function) inhibit capability for maintenance operations
- Battery-backed operation with automatic charging and supervision (24V standby system)
- Dedicated alarm priority outputs (P1 for heat/MCP, P2 for smoke)
- Visual system status indicators for power, fire and fault conditions
- Automatic re-sound feature for new alarm zones
- Zone-specific fault indication for targeted troubleshooting
- Easi-fit FA000 mounting base for ease of installation and servicing of alarm devices
- Supports FA016 smoke, FA014 heat, FA024 multi-sensor



1.2 Terms & Definitions

Terms	Description
FA40	FireAlert, 4 Zone RCIE
FA000	Alarm's mounting Base for connecting FA0xx series alarms to the FA40 RCIE.
FA014	Heat alarm using a Class A1 thermistor sensor, suitable for areas with smoke or fumes.
FA016	Photoelectric smoke alarm designed to detect smouldering fires.
FA024	COMING SOON - Multi-sensor alarm combining smoke and heat detection.
RCIE	Residential Control and Indicating Equipment
Smoke Alarm	A device capable of detecting smoke and generating an alarm condition. <i>(FA016 & FA024) At Brooks all smoke alarms are Type A, photoelectric smoke alarms</i>
Photoelectric Sensor	A sensor that detects visible products of combustion by using a light beam. Light is transmitted into the sensing chamber. When combustion products enter the sensing chamber they reflect the light to the sensor receiver, the sensor sends an alarm signal.
Heat Alarm	A device capable of detecting heat and generating an alarm condition. <i>(FA014 & FA024)</i>
Thermistor	A type of temperature-sensitive resistor whose resistance changes significantly with temperature.
Multi-criteria Alarm (Multi)	A fire alarm device incorporating within one mechanical housing more than one fire sensor with all sensors separately monitored for the presence or absence of an output signal relating to fire development, Where the output signals from each sensor are evaluated according to predefined algorithm to determine when an alarm condition is reached. Smoke + Heat sensor combined into 1 alarm where the alarm condition is determined by a response from both the smoke and heat sensors.
Combination alarm	A fire alarm device incorporating within one mechanical housing more than one fire sensor, with each sensor independently signalling an alarm condition.
CO Alarm	A device capable of detecting increasing levels of carbon monoxide (CO) which signals an alarm condition prior to toxic levels of CO being reached.
Alarm Type	Smoke (FA016), Heat (FA014), Smoke & Heat Multi-Sensor (FA024)
Alarm Condition	Visual and Audible signal to indicate the presence of fire.
Fault Condition	Visual and Audible signal given as indicating the existence of an actual or incipient fault that may prevent an alarm condition or transmission of an alarm signal to interconnected devices
Smoke alarm types	Type A: Smoke alarm that does not contain radioactive materials.
	Type B: Smoke alarm containing radioactive materials.
	Band 1: Response threshold greater than 0.05 dB/m



Smoke alarm Bands (AS 3786:2023)	Band 2: Response threshold greater than 0.2 dB/m
Heat Alarm Class (AS 1603.3:2018)	A1: Response threshold greater than 54°C but less than 65°C <i>(Brooks FA0xx series heat alarms are class A1)</i>
	A2: Response threshold greater than 54°C but less than 70°C
	B: Response threshold greater than 69°C but less than 85°C
	C: Response threshold greater than 84°C but less than 100°C
ACF	Ancillary Control Facility, output to trigger external ancillary devices during alarm condition.
Ancillary Control Facility	A dedicated output of the RCIE which provides for supplementary functionality when the smoke alarm system enters the alarm condition
I2C	A reliable two wire communication protocol.
UART	A hardware communication protocol used for serial communication between devices.
DIP Switch	A switch used to configure device settings.
EOL Resistor	End-of-Line resistor used to supervise wiring integrity in alarm circuits.
EOL Device	A device installed at the end of a transmission path providing a signal to residential control and indicating equipment, to supervise the transmission path.
Alarm zone	Area protected by one or more alarm devices which provides a common identification at the residential control and indicating equipment
Connectible device	Device for supplementary purposes, not conforming to a component standards referenced in AS1670.6, whose operation or failure will not jeopardise the performance of the smoke alarm system
Locate facility	Control facility within the RCIE used in conjunction with the zone alarm devices that enables the specific device or devices in the alarm condition to be identified

2 SYSTEM COMPONENTS

2.1 FireAlert Series Alarms (FA0xx)

Note: For more information on troubleshooting FA series alarm and what the LEDs on the device themselves indicate, refer to §6.1

Note: Brooks MRF module is not compatible with the FA series alarms.

Note: The FA series smoke alarms are not suitable for non-pure sinusoidal power sources.

2.1.1 Smoke Alarm (FA016)

2.1.1.1 Overview Description

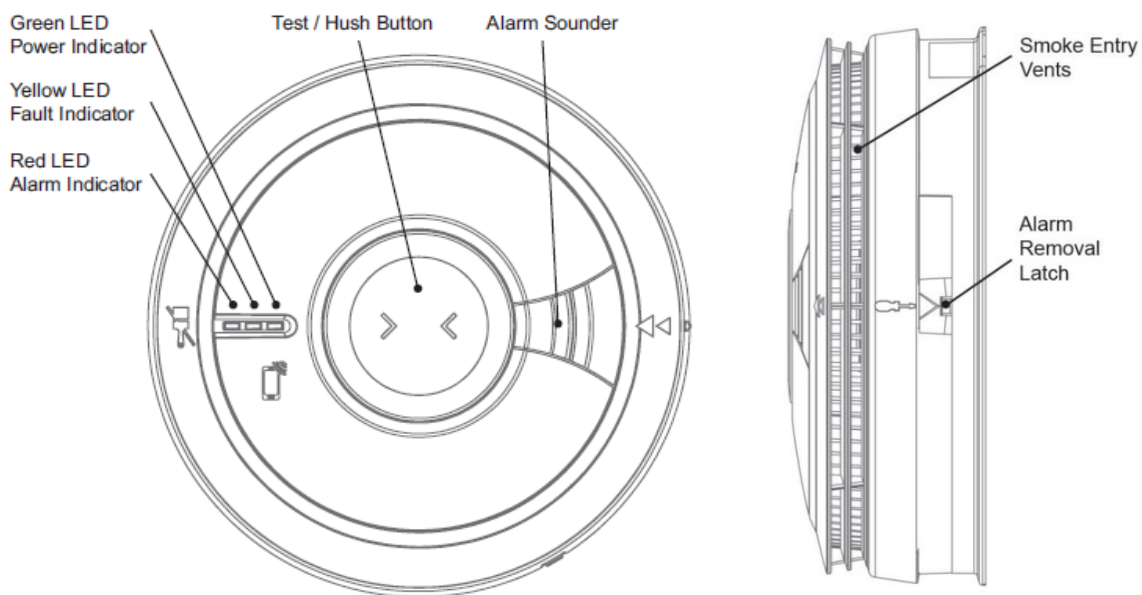

Figure 2: FA016 Smoke Alarm

The FA016 is a Photoelectric Smoke Alarm designed to detect smouldering fires. It is ideal for living rooms, in all sleeping areas, passageways, corridors, hallways and stairwells that are part of a path of travel to the exit door of the building. The smoke sensor is AS 3786:2023 Band 1. The chamber design and integrated insect screen reduces the risk of nuisance alarms; this coupled with the unique dust compensation algorithm extends the service life of the alarm.

The FA016 mounts onto the FA000 base, which draws its main and standby power from the FA40 RCIE. This in turn charges the integrated rechargeable standby battery within the FA016. In the event of power loss from the RCIE, this non removable rechargeable battery provides the FA016 with up to 6 months of operation. This non removable rechargeable battery has a 10-year service life.



The FA016 has a memory feature to identify if that alarm device has previously been in the alarm condition (through the red flashing LED). This feature assists in identifying an alarm device prone to nuisance alarms.

The FA016 self-checks its sensor, battery voltage, and internal circuitry every 48 seconds. Any fault condition found will be indicated by a combination of yellow LED flashes and sounder chirp at the alarm.

FA016 conforms to AS 3786:2014 Amds 1 & 2 as well as AS 3786:2023 Band 1.

2.1.1.2 Features

- **Band 1 Photoelectric Smoke Sensor:** Proven optical sensor for smouldering fires.
- **Test/Hush Button:** Tests sensors and silences alarms for 10 minutes.
- **Visual Indicators:** Green LED (power), Yellow LED (fault), Red LED (alarm/memory).
- **Self-Test:** Automatic periodic testing of sensors, batteries, and electronics.
- **Dust Compensation:** Automatically recalibrates the smoke sensor thereby reducing the false alarms caused by dust or contamination, thereby maximising service life.

2.1.1.3 Specifications

- **Power Supply:** 16 Vdc Power Source.
- **Battery Backup:** 10-year rechargeable lithium cells (6 months backup).
- **Alarm Sound Level:** 85dB(A) at 3 meters.
- **Operating Temperature:** -10°C to +40°C.
- **Humidity Range:** 15% to 95% RH (non-condensing).
- **Dimensions:** Ø150mm x 63mm.
- **Weight:** 350g (including packaging).
- **Approvals:** Conforms to AS 3786:2014 Amds 1 & 2 as well as AS 3786:2023 Band 1.
- **Service Life:** 10 years.

2.1.1.4 Operation

- Green LED indicates 16 Vdc power is available; flashing green indicates backup battery mode.
- Yellow LED and chirps indicate faults (e.g., sensor fault, low battery, end of life).
- Red LED indicates alarm or memory of a prior fire event.
- Use the Hush button to silence nuisance alarms for 10 minutes.

Note: Within the FA40 system, if the hush button is activated directly on the alarm unit, the FA40 panel will not indicate the silence condition.

2.1.2 Heat Alarm (FA014)

2.1.2.1 Overview Description

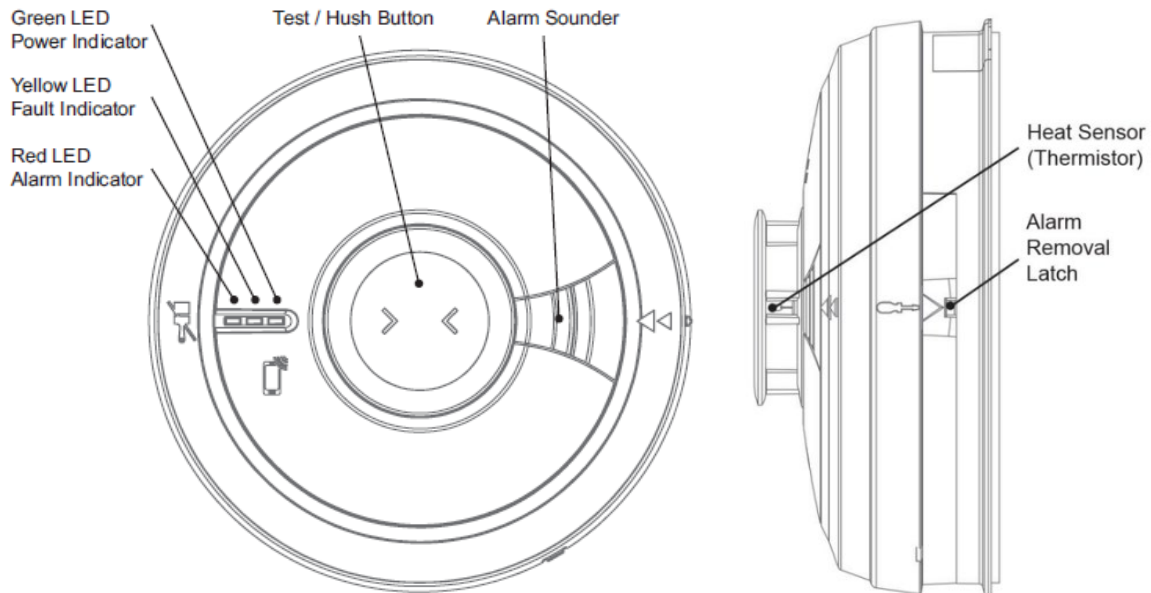

Figure 3: FA014 Heat Alarm.

The FA014 is a heat alarm incorporating a Class A1 thermistor heat sensor. FA014 detects heat and therefore is not considered to provide an early warning of fire. It is specifically designed for kitchens, garages, and areas with elevated levels of fumes, smoke, or dust are likely, where the installation of a smoke alarm may cause excessive nuisance alarms. As such the FA014 must be used as a supplementary device to the smoke alarms within FireAlert.

The FA014 mounts onto the FA000 base, which draws its main and standby power from the RCIE. This in turn charges the integrated rechargeable standby battery within the FA014. In the event of power loss from the RCIE, this non removable rechargeable battery provides the FA014 with up to 6 months of operation. This non removable rechargeable battery has a 10-year service life.

The FA014 self-checks its sensor, battery voltage and internal circuitry every 48 seconds. Any fault condition found will be indicated by a combination of yellow LED flashes and sounder chirp at the alarm.

The FA014 has a memory feature to identify if that specific alarm device has previously been in the alarm condition (through the red flashing LED). This feature assists in identifying an alarm device prone to nuisance alarms.

The FA014 conforms to AS 1603.3:2018.

2.1.2.2 Features

- **Heat Sensor:** Fast reacting Class A1 thermistor for detecting heat from fires.
- **Test/Hush Button:** Tests sensors and silences alarms for 10 minutes.
- **Visual Indicators:** Green LED (power), Yellow LED (fault), Red LED (alarm/memory).



-
- **Self-Test:** Automatic periodic testing of sensors, batteries, and electronics.

2.1.2.3 Specifications

- **Power Supply:** 16 Vdc power source derived from FA000 Base.
- **Battery Backup:** 10-year non removable rechargeable lithium cells (6 months backup).
- **Alarm Sound Level:** 85dB(A) at 3 meters.
- **Operating Temperature:** -10°C to +40°C.
- **Humidity Range:** 15% to 95% RH (non-condensing).
- **Dimensions:** Ø150mm x 66mm.
- **Weight:** 350g (including packaging).
- **Approvals:** Conforms to AS 1603.3:2018.
- **Service Life:** 10 years.

2.1.2.4 Operation

- Green LED indicates 16Vdc power is available; flashing green indicates backup battery mode.
- Yellow LED and chirps indicate faults (e.g., sensor fault, low battery, end of life).
- Red LED indicates alarm or memory of a prior fire event.
- Use the Hush button to silence nuisance alarms for 10 minutes.

Note: Within the FA40 system, if the hush button is activated directly on the alarm unit, the FA40 panel will not indicate the silence condition.

2.1.3 Multi-Sensor Alarm (FA024) *COMING SOON*

2.1.3.1 Overview description

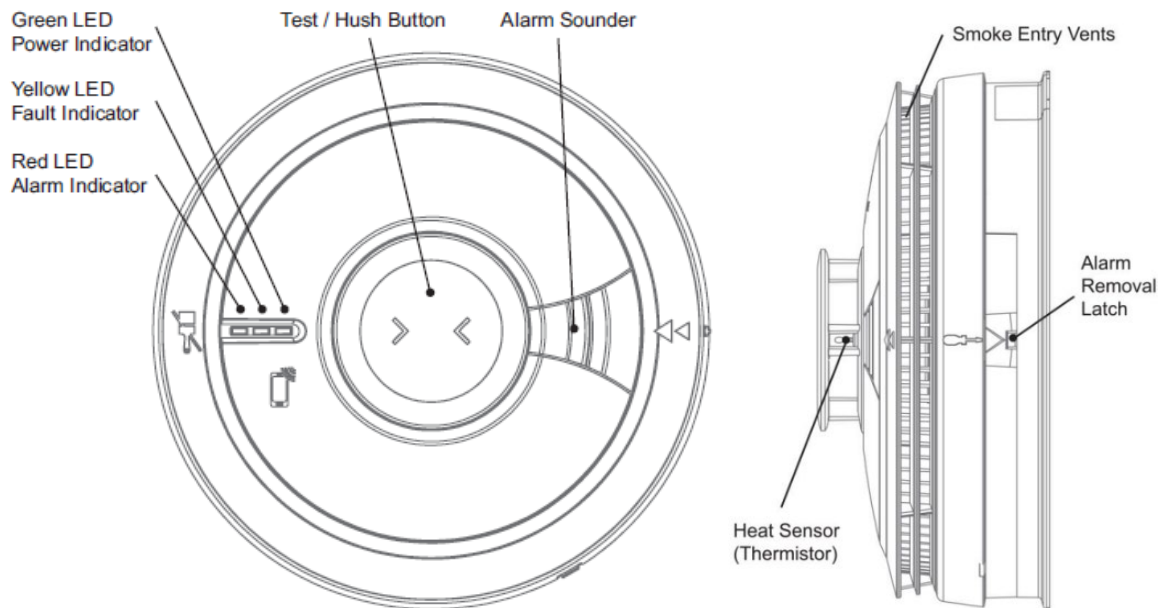

Figure 4: FA024 Multi-Sensor (coming soon)

The FA024 is multi-sensor alarm equipped with a photoelectric smoke sensor (AS 3786:2023 Band 1) and a Class A1 thermistor heat sensor. This combination of smoke and heat sensors in conjunction with the FA024 sensor algorithm monitors for both smoke and heat development during a fire. The algorithm monitors the status of both sensors. With no heat signal, the smoke sensor is set to Band 2 (less sensitive), which provides a measure of nuisance alarm mitigation from non-fire related conditions.

As a real fire generates both heat and smoke, the sensor algorithm enables the FA024 to respond more quickly to a real fire. If a heat sensor signal is present the smoke sensor is automatically recalibrated to band 1 (more sensitive). Monitoring the signal from both sensors confirms there is an actual fire. By combining sensor signals, the FA024 will initiate a fire alarm prior to either sensor reaching its separate alarm threshold. The heat sensor enhancement enables the FA024 to respond to a real fire faster than a single sensor smoke alarms. The FA024 complies with all test fires (TF1 to TF6 and TF8) thereby providing effective fire detection across a broader range of fire types.

The FA024 is a smoke alarm for the purpose of system design (AS1670.6) and is ideal for living rooms, in all sleeping areas, passageways, corridors, hallways, and stairwells that are part of an escape path from the building.

The FA024 mounts onto the FA000 base, which draws its main and standby power from the FA40 RCIE. This in turn charges the integrated rechargeable standby battery within the FA024. In the event of power loss from the RCIE, this non removable rechargeable standby battery provides the FA024 with up to 6 months of operation. This non removable rechargeable battery has a 10-year service life.



The FA024 self-checks both of its sensors, battery voltage, and internal circuitry every 48 seconds. Any fault condition found will be indicated by a combination of yellow LED flashes and sounder chirp at the alarm.

The FA024 has a memory feature to identify if that specific alarm device has previously been in the alarm condition (through the red flashing LED). This feature assists in identifying an alarm device prone to nuisance alarms.

The FA024 conforms to both AS 3786:2014 Amd. 2, AS 3786:2023 Band 1 & AS 1603.3:2018

2.1.3.2 Features

- **Photoelectric Smoke Sensor:** Proven optical sensor for smouldering fires
- **Heat Sensor:** Class A1 thermistor for detecting heat from fires.
- **Interconnection:** Supports up to 40 alarms per system/ 10 alarms per RCIE zone (via hardwired interface with FA-BASE)
- **Test/Hush Button:** Tests sensors and silences alarms for 10 minutes.
- **Visual Indicators:** Green LED (power), Yellow LED (fault), Red LED (alarm/memory).
- **Self-Test:** Automatic periodic testing of sensors, batteries, and electronics.

2.1.3.3 Specifications

- **Power Supply:** Main Power Source derived from FA000 Base (+16Vdc)
- **Battery Backup:** 10-year rechargeable lithium cells (6 months backup without module).
- **Alarm Sound Level:** 85dB(A) at 3 meters.
- **Operating Temperature:** -10°C to +40°C.
- **Humidity Range:** 15% to 95% RH (non-condensing).
- **Dimensions:** Ø150mm x 70mm.
- **Weight:** 350g (including packaging).
- **Approvals:** Conforms to both AS 3786:2023 & AS 1603.3:2018.
- **Service life:** 10 years.

2.1.3.4 Operation

- Green LED indicates +16Vdc power; Flashes every 48 seconds to indicate unit is running on battery.
- Yellow LED and chirps indicate faults (e.g., sensor fault, low battery, end of life).
- Red LED indicates alarm or memory of a prior fire event.
- Use the Hush button to silence nuisance alarms for 10 minutes.

Note: Within the FA40 system, if the hush button is activated directly on the alarm unit, the FA40 panel will not indicate the silence condition.

2.2 Easi-fit FA Base (FA000)

2.2.1 Overview Description

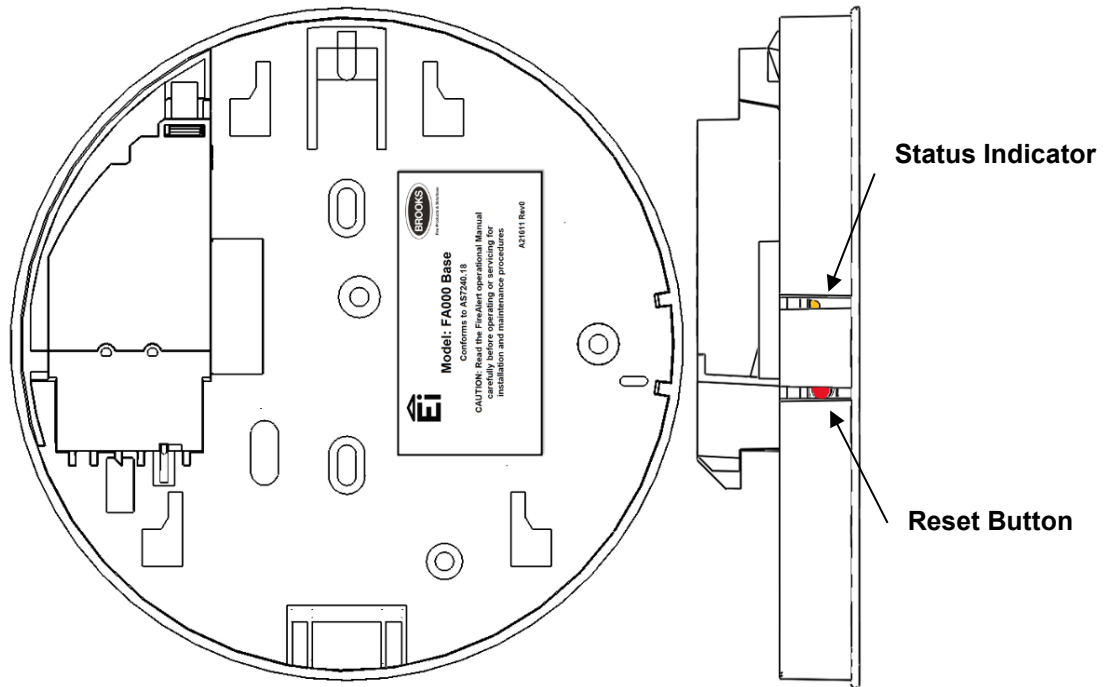

Figure 5: FA000

The Easi-fit FA000 has an interface card that connects FA series alarm devices to the FA40 RCIE zone circuits. DIP switches on the FA000 select the device type (FA014 heat, FA016 smoke or, FA024 smoke and heat) for proper identification by the RCIE. The FA40 displays device removal alerts when an alarm device is removed from its base. The FA000 provides terminals for all field wiring connections and includes status LEDs to indicate operational state.

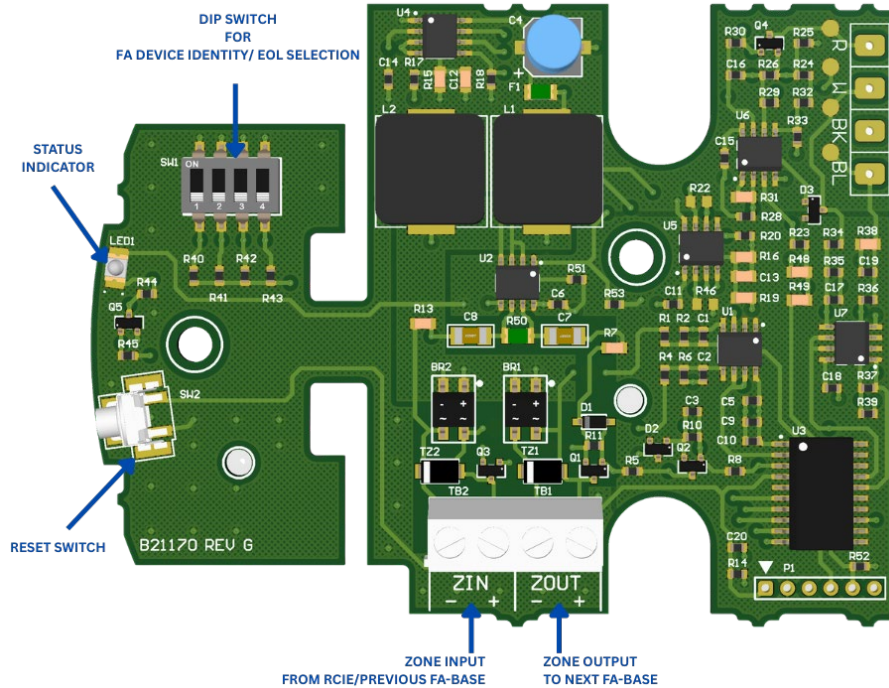

Figure 6: FA000 Interface Board

The status indication is observable when the alarm point is attached in its normal orientation, refer to §2.2.3 Status Indicator. A reset switch is provided for config or installation trouble shooting whilst the alarms are installed in their normal orientation. This will generally be used for identifying the type of alarm and forcing the attached alarms into their default mode of operation refer to §2.2.4 Reset Button.

2.2.2 Head Configuration

The FA000 base uses DIP switches to identify the alarm type connected (FA014, FA016 or, FA024) to the FA40 RCIE. Switch 4 must be set to ON when the FA000 is the last device on a zone circuit (EOL).

Table 1 Dip Switch Settings of FA000 Base

Function	1	2	3	4
FA016 (Smoke)	OFF	OFF	OFF	
FA014 (Heat)	OFF	OFF	ON	
FA024 (Multi-Sensor)	OFF	ON	ON	
Last Device (EOL)				ON

Table 2: FA000 Base DIP Switch Combinations

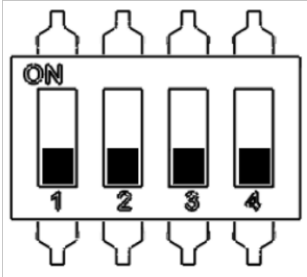
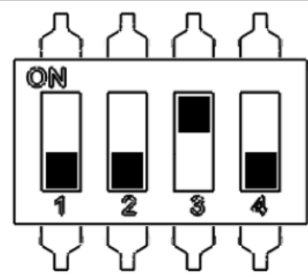
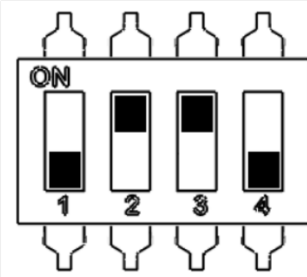
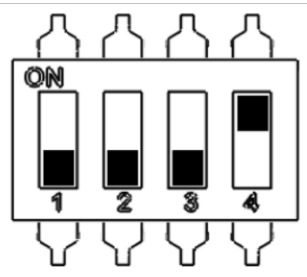
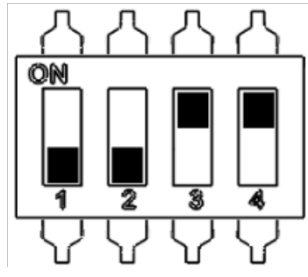
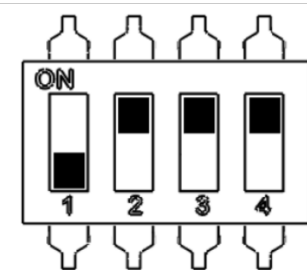
FA016	FA014	FA024
		
 <p>FA016 EOL Enabled</p>	 <p>FA014 EOL Enabled</p>	 <p>FA024 EOL Enabled</p>

2.2.3 Status Indicator

The yellow status indicator LED on the side of the FA000 Base is designed to signal abnormal operating conditions. Its behaviour varies depending on the nature of the fault:

Table 3: FA000 Base Fault Indicator

Condition:	LED Behaviour:	Description:
Unconfigured FA000 Base	ON	Indicates the device is not configured; requires attention
Internal Fault	Fast flash (4 Hz)	Hardware or checksum error detected
System/Communication Fault	Slow flash (1 Hz)	Bus error or communication issue present
Normal Operation	OFF	System functioning normally

At startup or after a short press of the reset button, the device's address is indicated by the Fault LED flashing. Count the flashes to determine the address:

- **Addresses 1–5:** The Fault LED flashes the corresponding number of times.
- **Addresses 6–10:** One long flash followed by short flashes indicates the address.
Example: Address 8 = 1 long flash + 3 short flashes.

This flashing pattern continues for 10 minutes after the ELV receives power and successfully communicates with the FA40 RCIE. This gives installers sufficient time to check each base.

2.2.4 Reset Button

Note: The FA000 base's comes programmed as address zero from factory, upon initial or first startup of the FA000 connected to an FA40 panel, the address of the FA000 will be automatically programmed with an address from 1 to 10 sequential depending on position within zone.

The reset button on the side of the FA000 base is used to either identify the address of the FA000 base or to factory reset the FA000 base back to default address.

To press the reset button, insert a 3mm flat head screwdriver or pointy object carefully into the slot of the FA000 shown below:

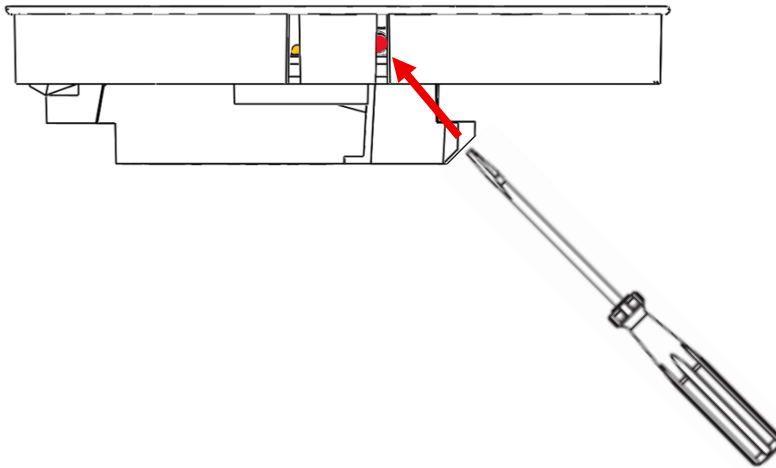

Figure 7: Pressing FA000 Reset button.

2.2.4.1 FA000 device address identification:

Short press (>2, less than 5 Seconds)

Pressing and holding the reset button down for >2 seconds will cause the device to start flashing its address.

Once the FA000 base starts flashing its address, remove the flat head screwdriver from the reset button. The address of the FA000 will continue to flash for 1 minutes according to the flash pattern as described in §2.2.3

2.2.4.2 FA000 device Factory reset:

Long press (>5 Seconds)

Pressing and holding the reset button down for >5 seconds and/or until the FA000 status indicator turns solid yellow.

This will reset the FA000 device's address back to zero and will require a FA40 initial device setup to occur, refer to §3.3.2

2.3 Residential Control and Indicating Equipment (FA40)

2.3.1 Overview Description



The FA40 RCIE is a four-zone fire alarm control panel housed in an injection-moulded plastic enclosure and provides four zone circuits, with each zone supporting up to 10 fire alarm devices for a system maximum of 40 devices. Communication with field devices occurs through the FA000 base units using 2 wire Data over power technique, ensuring reliable fire detection, alarm notification, and system monitoring.

The FA40 includes a main control board with integrated zone circuits, a power supply supervision board, a 3.5-amp switch mode power supply, field wiring terminations, AC mains input termination with fuse protection, and a 24V standby battery system (2 × 12V 9Ah batteries in series). The 3.5-amp power supply sets the system's power budget. The system's power limitations are a combination of the number of devices required, any ancillary loads connected and the standby time required in the event of main power loss (see CI 3.1.4).

The system provides zone-specific alarm indication, comprehensive fault monitoring, user control functions, and common alarm/fault outputs.

The FA40 RCIE has an integral zone display on the front panel which provides all the necessary indicators for indication of alarm condition, system status and system control. Custom zones descriptions can be added to the display –Refer to §3.1.6 for installation instructions.

The injection moulded enclosure provides for the mounting of a zone block diagram as per AS 1670.6 –Refer to §3.1.7 for installation instructions.

The FA40 conforms to the applicable requirements of AS 7240.2 and AS 7240.4

Note: The FA40 is a CISPR-32:2012 Class A product. In a domestic environment, this product may cause interference.

Note: The FA40 RCIE cannot be expanded in either the number of zones or power supply output.



Table 4: FA40 Specifications

Item	Specification
Mains 230Vac	195 / 253V AC, 1.3A
Systems Voltage	24Vdc @ 3.5A
P _{min}	4.0 Watts
P _a _{max}	63.1 Watts
P _b _{max}	93 Watts
R _i	0.8Ω
Battery Backup	2 x 12V 9Ah Fire Rated SLA batteries
Ambient Temperature: Operating Storage	-0°C to +40°C (indoor use only) -5°C to +50°C
Ambient Humidity (%RH)	Maximum 90, non-condensing
Altitude	< 2000 m above sea level
Cabinet Size (mm)	450 x 350 x 125 (H x W x D)
Cabinet Weight (kg)	4kg, excluding batteries. 9kg with 2 x 12V 9Ah batteries
Cabinet Material	UL 94 V-0 Fire rated plastic (Full compound ABS)
Ingress protection	IP 30
Acceptable Pollution Degree	Degree 1 and 2, <i>non-conducting pollution, and occasional temporary condensation is to be expected.</i>
Approvals	Conforms to AS 7240.2:2018, AS 7240.4:2018

2.3.2 FA40 Main Control Board

2.3.2.1 Description

The main control board performs all processing and control functions for the FA40 system, it provides four zone circuits, each supporting up to 10 alarm devices (40 total system maximum). It connects to field devices via two-wire zone circuits, utilizing data-over-power technology for reliable communication in electrically noisy environments. All zone circuits are continuously supervised for open circuit, short circuit, and device removal faults to ensure system integrity.

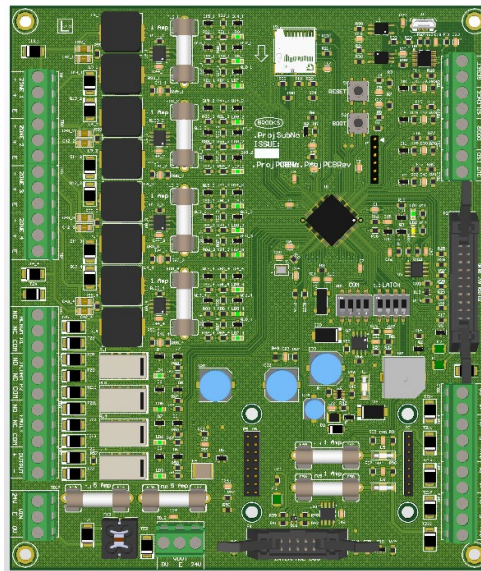

Figure 8: FA40 Main Control Board

The FA40 Main control board provides some level of customisation via way of dip switches, refer to §2.3.2.4 for further information.

System Outputs:

- Priority 1 (P1) relay - Activates for heat, MCP, or sprinkler alarms (voltage-free contacts with maximum switching capability 24Vdc/1A)
- Priority 2 (P2) relay - Activates for smoke alarms (voltage-free contacts with maximum switching capability 24Vdc/1A)
- General Fault relay - Indicates any system fault condition (normally energised voltage-free contacts with maximum switching capability 24Vdc/1A)
- ACF Output - Supervised 24Vdc output (550mA maximum) with inhibit control for maintenance §2.3.2.3

2.3.2.2 Board Connection

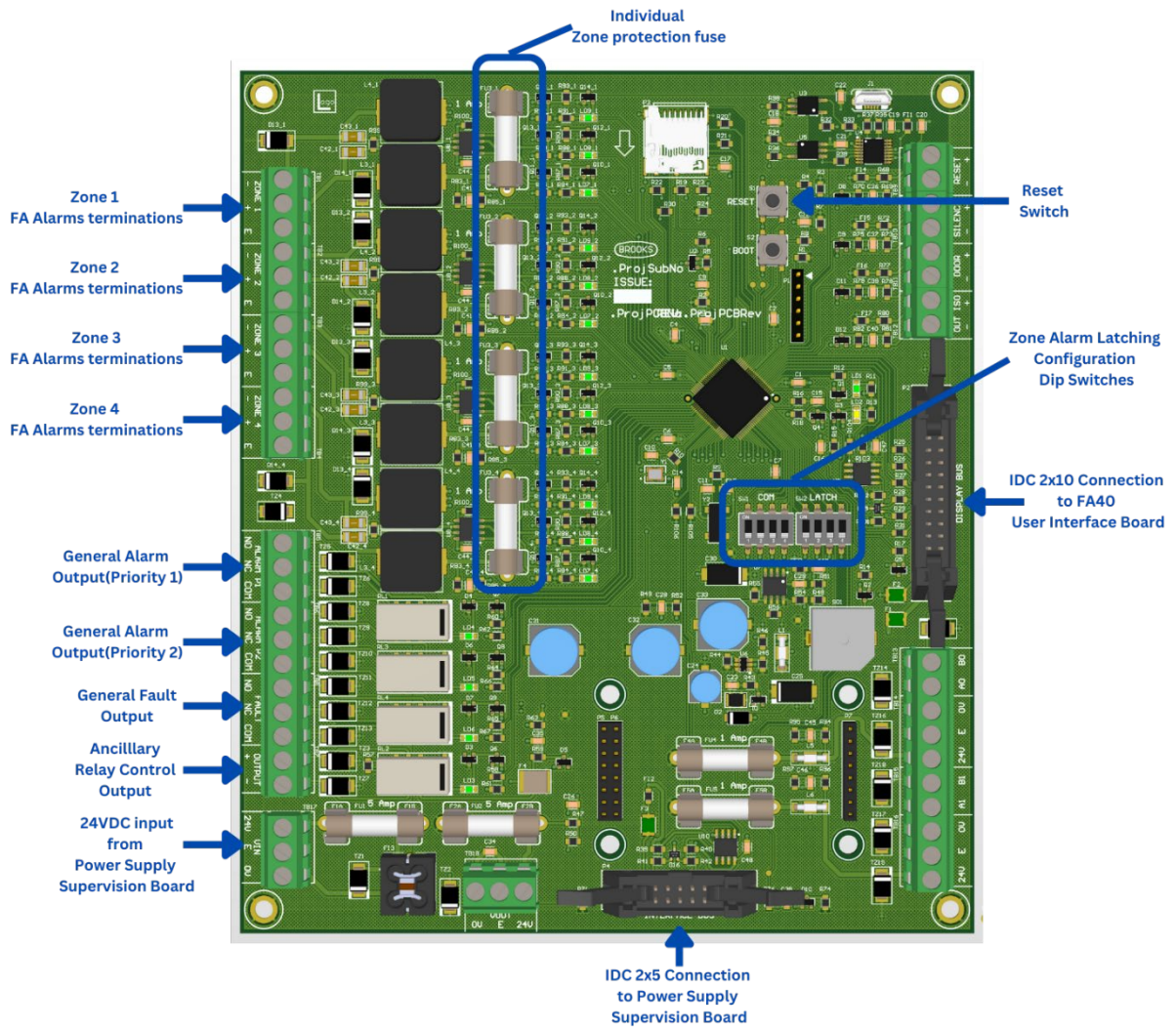

Figure 9: FA40 Main Control Board Connection



Fire Products & Solutions



FA40 Operation Manual

FireAlert Smoke Alarm System Iss 0.5

Table 5 FA40 Main Control Board Connection

Designator	Type	Label	Pin	Description
TB1	Screw Terminals	Zone 1	-	To FA Alarms Devices at the field
			+	
			E	
TB2	Screw Terminals	Zone 2	-	To FA Alarms Devices at the field
			+	
			E	
TB3	Screw Terminals	Zone 3	-	To FA Alarms Devices at the field
			+	
			E	
TB4	Screw Terminals	Zone 4	-	To FA Alarms Devices at the field
			+	
			E	
TB5	Screw Terminals	Alarm P1	NO	Priority 1 General Alarm Dry-contact output (Heat/MCP/Sprinkler)
			NC	
			COM	
TB6	Screw Terminals	Alarm P2	NO	Priority 2 General Alarm Dry-contact output (Smoke)
			NC	
			COM	
TB7	Screw Terminals	Output	+	Ancillary Control Function Output +24Vdc, 550mA Maximum current output.
			-	
TB8	Screw Terminals	Fault	NO	General fault Dry-contact Output (Output Normally Energised)
			NC	
			COM	
TB17	Screw Terminals	Vin	24V	24Vdc connection from Power Supply Supervision Board
			E	
			0V	
P2	IDC header 2x10	Display Bus		Power & Data Comms to FA40 User Interface
P4	IDC header 2 x 5	Interface Bus		Data Comms to Power Supply Supervision Board



Fire Products & Solutions

firealert

FA40 Operation Manual

FireAlert Smoke Alarm System Iss 0.5

2.3.2.3 Ancillary Control Facility (ACF) output

The ACF output is a supervised 24Vdc output (550mA maximum) designed to trigger ancillary devices, such as door holders, ventilation shutdowns, or alarm transmission equipment, during alarm conditions

The ACF output requires a 47k Ω end-of-line (EOL) resistor connected across the positive and negative terminals at the last device. This resistor enables the FA40 to continuously monitor the circuit integrity. Without this resistor, the system will indicate an ACF output fault §4.3.

ACF output is monitored for:

- **Open circuit** (broken wire or missing EOL resistor)
- **Short circuit** (wiring fault) -when a fault is detected, the ACF Fault LED illuminates and the fault buzzer sounds.

An ACF inhibit control is provided for allowing authorized service technicians/personnel to temporarily inhibit the operation of the ACF output during maintenance or testing. Refer to §4.2.5 for more information.



2.3.2.4 Dip Switches Settings

The specifications for dip switches settings are as follows.

COM (Common Alarm) Switches:

When a zone's COM switch is set to ON, that zone operates in common alarm mode. In this mode, if any alarm activates in that zone, it will trigger ALL alarms across ALL zones in the system, regardless of the other zones' COM settings. This creates a building-wide alert from a single zone activation.

When set to OFF, the zone operates independently - alarms in that zone will only sound the devices within that specific zone unless another zone with COM=ON is triggered.

Example: If Zone 2 COM is ON and Zone 2 detects smoke, all alarms in Zones 1, 2, 3, and 4 will activate simultaneously, providing full building notification.

Note: A priority 1 alarm will set off all zones as if that zone was configured for common alarm.

Table 6 “COM” Dip Switch Positions

Function	1	2	3	4
Zone 1 setup for common activation	ON	OFF	OFF	OFF
Zone 2 setup for common activation	OFF	ON	OFF	OFF
Zone 3 setup for common activation	OFF	OFF	ON	OFF
Zone 4 setup for common activation	OFF	OFF	OFF	ON

Table 7 Main Control Board Fuse Specifications.

Designator	Circuit Protected	Specification
FU1	Power Input	Fast Acting M205 Ceramic Fuse 5A.
FU2	Power Output to Zone Extension Module	Fast Acting M205 Ceramic Fuse 5A.
FU3-1, FU3-2, FU3-3, FU3-4	Individual Zone Circuit 1-4	Fast Acting M205 Ceramic Fuse 1A.
FU4	Power Output 1 to Optional Module	Fast Acting M205 Ceramic Fuse 1A.
FU5	Power Output 1 to Optional Module	Fast Acting M205 Ceramic Fuse 1A.

2.3.3 FA40 User Interface Display Board

2.3.3.1 Description

The FA40 user interface display board provides a simplified zone description and indicators for each zone status, general system status and user-friendly button to control the system. It directly communicates with the main control board via the display IDC cable displaying system status and controlling the system at proper access level. The unit incorporates a cover detection switch to monitor access and identify any tampering attempts when the system is opened without authorised access.



Figure 10: FA40 User Interface Display Board

Indicators:

- Power ON (Green)
- General Fire (Red)
- General Fault (Amber)
- ACF Inhibit (Amber)
- ACF Delay (Amber, – Output delay feature has been activated)
- ACF Active (Red)
- Zone Fire (each zone, Red)
- Zone Fault (each zone, Amber)
- Smoke (Red, flashing interlocked to zone alarm – identifies the zonal alarm condition has resulted from smoke detection)
- Heat (Red, interlocked to zone alarm – identifies the zonal alarm condition has resulted from Heat detection)
- MCP (Red, interlocked to zone alarm – identifies the zonal alarm condition has resulted from Manual call point activation)
- Sprinkler (Red, interlocked to zone alarm – identifies the zonal alarm condition has resulted from residential sprinkler system activation)
- ACF fault (Amber, – Supervised Alarm O/P fault)



- PSU Fault (Amber)
- CPU fault (Amber)
- Earth fault (Amber)
- System Fault (Amber)

Controls with Indicators:

- Silence Buzzer – mutes the integral RCIE fire/fault buzzer. Automatically resets to normal after the fault condition is cleared.
- Locate Alarm – silences all FA alarms except the Alarm(s) that have actuated. Used to locate the source of the fire or contaminated Smoke / Alarm.
- Silence Alarm – silences all FA alarms
- ACF Inhibit –Inhibit Ancillary Control Facilities output at main control board.

Controls without Indicators:

- Reset – Place the system into normal condition.
- 003 Key Switch –Access Level control.

2.3.3.2 Board Connection

Table 8 Connection of FA40 User Interface Board

Designator	Type	Label	Pin	Description
P1	IDC header, 2x10	TO MAIN BOARD		Connection to Main Board for Power & I2C data comms
TB1	Screw Terminals	DOOR Switch I/P	C	Door input, door open/close detection
			NO	
TB1	Screw Terminals	KEY Switch I/P	C	Access Key in, 003 Key for access level 1 & 2
			NO	

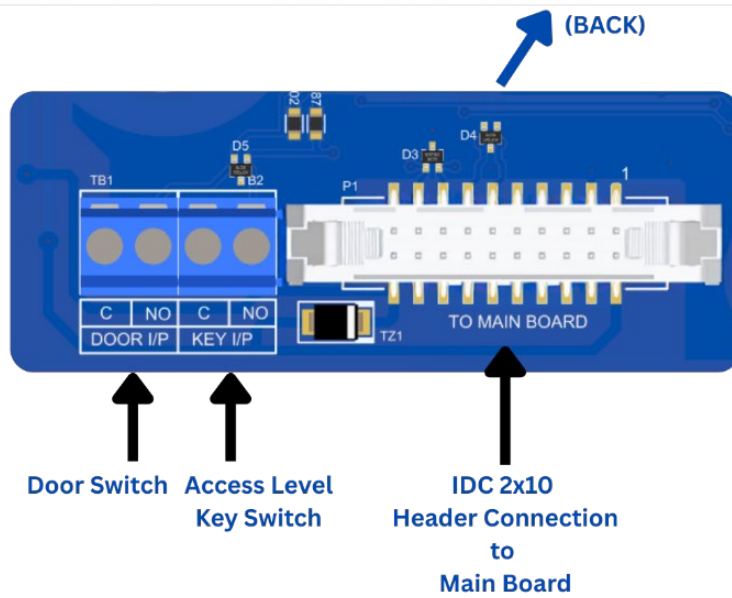

Figure 11: FA40 User Interface Board Connection

2.3.4 The FA40 Power Supply

2.3.4.1 Description

The FA40 RCIE consists of power supply supervision module, 3.5A switch mode power supply and 2 x 12V 9Ah batteries. The power supply supervision module used in the FA40 RCIE is configured to be working only as 100W power supply with 9Ah batteries back-up via dip switch.

The power supply supervision module constantly monitors the main power source status and the standby batteries power source status. The power supply supervision module also has capability to detect the earth fault in the system and show it on the display board. The power supply supervision will periodically test batteries to ensure they are still in their optimal operation conditions. This module will also automatically charge the connected batteries. Fault statuses are indicated on the power supply supervision board as well as the FA40 user interface. Refer to §Table 13 Power Supply Supervision LED indications and description-1 & §Table 14 for more information.

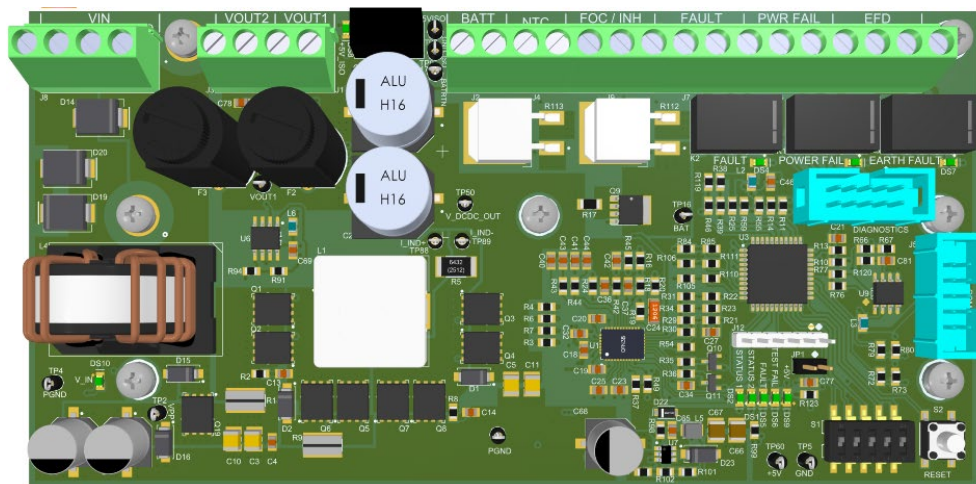

Figure 12: Power Supply Supervision Board

The power supply supervision module continuously monitors the battery charging and batteries status to detect any of the following fault conditions:

- Mains failure
- Batteries disconnected
- Batteries voltage low
- Batteries internal resistance high
- Earth leakage fault
- Fuse status for outputs 1 & 2

2.3.4.2 Features

Inputs:

- Batteries input (2 x 12V 9Ah batteries, in series).
- DC voltage input (from Switch Mode Power Supply).
- Test Inhibit Input -operates when the terminals INH(IN) and INH(OUT) are shorted together.
- Battery temperature sensor (NTC thermistor) input. NTC terminal uses NTC thermistor to monitor battery temperature.



Outputs:

- Two +24VDC outputs.
- Power Fail Fault– voltage free contact.
- General Fault – voltage free contact.
- Earth Fault – voltage free contact.
- Open collector fault output FOC(OC). The terminal is high impedance on normal state and active low when a fault occurs.
- Mains output (MO). The terminal is a current limited terminal to indicate a voltage presence on the primary power source.

Others:

- Communicate general status of power supply supervision module to main board via CA105 power supply cable.
- Selectable power supply/ battery capacity via dip switch setting (100W/ 150W & 320W)

Note: the FA40 has a maximum power output of 100W

- Periodic battery internal resistance check

2.3.4.3 Specifications

The specifications shown in the table below include absolute maximum ratings. Exceeding these limits will cause permanent damage to the module.

Table 9 Power Supply Supervision Specifications

Parameter	Value
Nominal Input Voltage	24V ±10%
Nominal Output Voltage	26.5V ±10%
Current Consumption @ Quiescent	89 mA
Max System Power	100/ 150/ 320watts
Max System Current	3.5/ 6.5/ 12A
Max Charge Current	0.8/ 1.8/ 2.8A
Recommended Battery Type	Fire Rated, Sealed Lead Acid
Min Battery Size	7Ah
Max Battery Size	18/ 42/ 65Ah
Relay Contact rating	30Vdc, 1A, 30watts max

Note: The power supply supervision is configured as 100W/ 9AH setting for the FA40 RCIE



2.3.4.4 DIP Switch Settings

Note: The Power supply supervision card can be configured for systems that exceed the capabilities of the FA40 system. The FA40 Power supply will be pre-configured from factory and should not be adjusted.

The FA40's power supply DIP switch configuration should be all OFF, except for the Earth Fault detection enable (DIP switch 5).

Table 10 Power Supply Supervision DIP switch & configurations

Function	1	2	3	4	5
PSU Selection (100W)	OFF	OFF			
PSU Selection (150W)	OFF	ON			
PSU Selection (320W)	ON	OFF			
BATT Selection (7-18AH)			OFF	OFF	
BATT Selection (18-42AH)			OFF	ON	
BATT Selection (42-65AH)			ON	OFF	
Earth Fault Detection Enable					ON

Note: Invalid Dip Switch Settings will result in showing PSU Fault on startup of the PSSC the +24V output will not be enabled.

Table 11 Power Supply Supervision Fuse Specifications

Designator	Circuit Protected	Specification
F2	Power Output-1	Fast Acting M205 Ceramic Fuse 6A.
F3	Power Output-2	Fast Acting M205 Ceramic Fuse 6A.

2.3.4.5 Board Connection

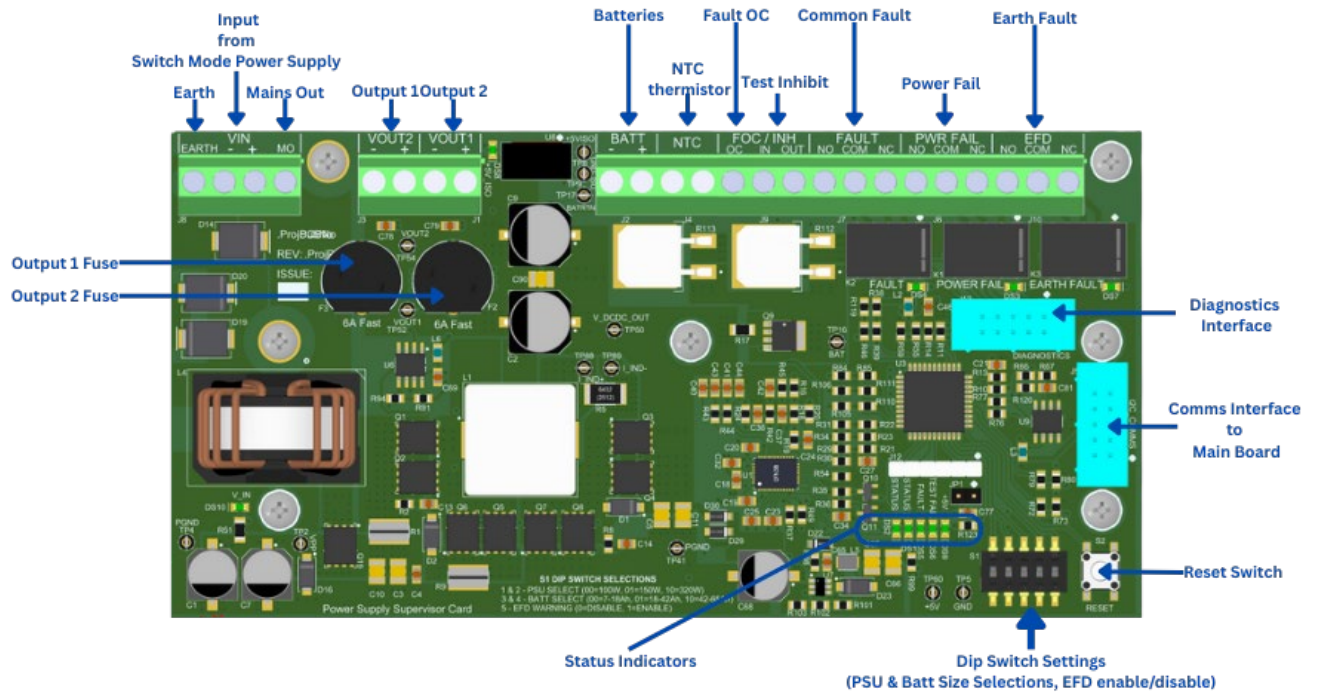

Figure 13: Power Supply Supervision Board Connection

Table 12 Connection of the Power Supply Supervision Board

Designator	Type	Label	Pin	Description
J1	Screw Terminals	VOUT1	+	Power source output 1
			-	
J2	Screw Terminals	BATT	+	Secondary power source input
			-	
J3	Screw Terminals	VOUT2	+	Power source output 2
			-	
J4	Screw Terminals	NTC	1	Battery temperature sensor input
			2	
J5	IDC header, 2x5	I2C_COMMS		I2C Connection to Main Control Board
J6	Screw Terminals	POWER FAIL	NO	Voltage free primary power source fails relay contact output. This output is normally energized.
			COM	
			NC	
J7	Screw Terminals	FAULT	NO	Voltage free common fault relay contact output
			COM	
			NC	
J8	Screw Terminals	VIN	EARTH	Earth Terminal
			-	



			+	Primary power source input.
			MO	Primary power source status output. Mains On (MO)
J9	Screw Terminals	FOC/INH	OC	Open collector fault output Test Inhibit Input. Shorting this contact IN & OUT will inhibit the periodic battery test
			IN	
			OUT	
J10	Screw Terminals	EFD	NO	Voltage free earth fault relay contact output
			COM	
			NC	
J12	Pin Header			Programming Header (Internal Use)
J13	IDC header, 2x5	DIAGNOSTICS		Diagnostics Interface (Internal Use)

Table 13 Power Supply Supervision LED indications and description-1

Designator	Label	Colour	Conditions			
DS1	Status 2	Green	ON	ON	OFF	OFF
DS2	Status 1	Green	ON	OFF	ON	OFF
			Bulk Charging Stage	Absorption Charging Stage	Float Charging Stage	Not Charging

Table 14 Power Supply Supervision LED indications and description -2

Designator	Label	Colour	Conditions	Description
DS3	Power Fail	Green	ON	Output Voltage is present
DS4	Fault (Relay)	Amber	ON	General PSSC fault relay is activated
DS5	Fault	Amber	ON	General fault at PSSC
DS6	Test Fail	Amber	ON	Battery impedance test fail
DS7	Earth Fault	Amber	ON	Earth leakage detected
DS8	+5V_ISO	Green	ON	Output Switch 5V Bootstrap Supply is present
DS9	+5V	Green	ON	Main 5V Supply is present
DS10	Vin	Green	ON	Vin 24Vdc is present

3 INSTALLATION & COMMISSIONING

3.1 FA40 Cabinet Installation:

FA40 LV fixed wiring installation and connections must be carried out by a licensed electrician.

FA40 cabinet to be installed in accordance with Australian Installation requirements as detailed in AS 1670.6

The FA40 cabinet is designed to be wall mounted.

To access the internals and for mounting of the FA40 you will need to unscrew the front cover, via the M3 screw found at the bottom of the cabinet:

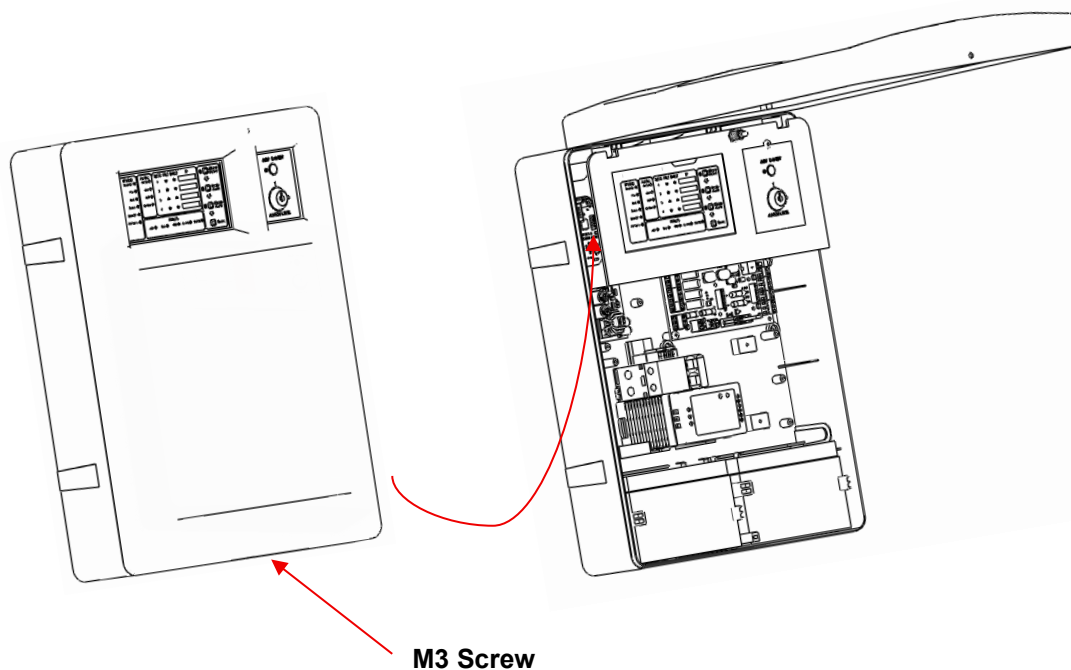

Figure 14: Access to FA40's internals.

3.1.1 Electrical Safeguards

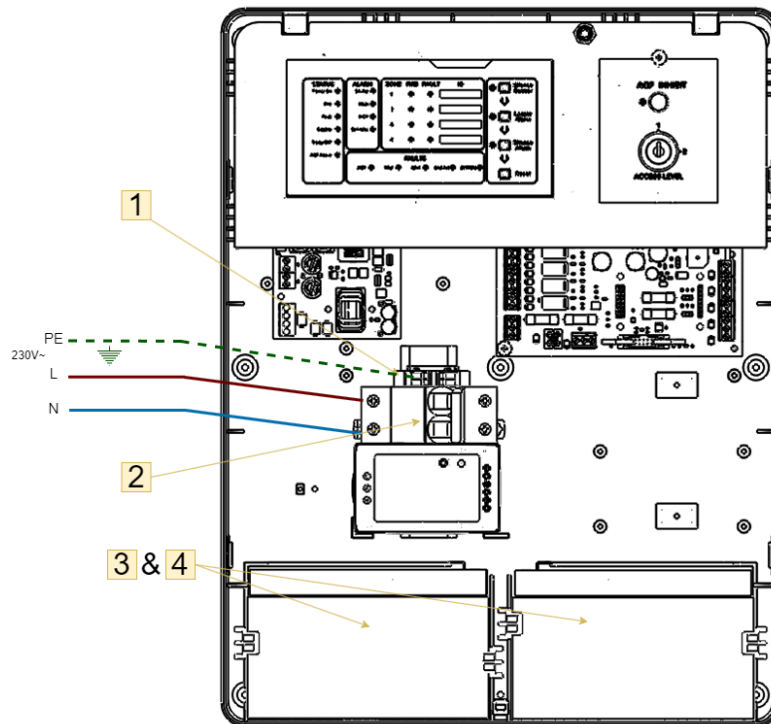





Figure 15: FA40 Electrical Safeguards

Table 15: Electrical Safeguards

Item	Description	Marking / Instructions
1	Protective earth (ground). Make sure to connect the protective earth conductor when installing the FA40.	
2	Mains power disconnects. Make sure to disconnect the equipment from the power before servicing.	
3	Make sure to disconnect Battery connection spade lugs before servicing.	
4	Risk of explosion if batteries are replaced by incorrect type. See §2.3.4	

3.1.2 Cabinet Mounting

6 Positions for fasteners are provided with OD = 4mm. The FA40 shall be mounted vertically, more than 750mm above the floor and not more than 1850mm.

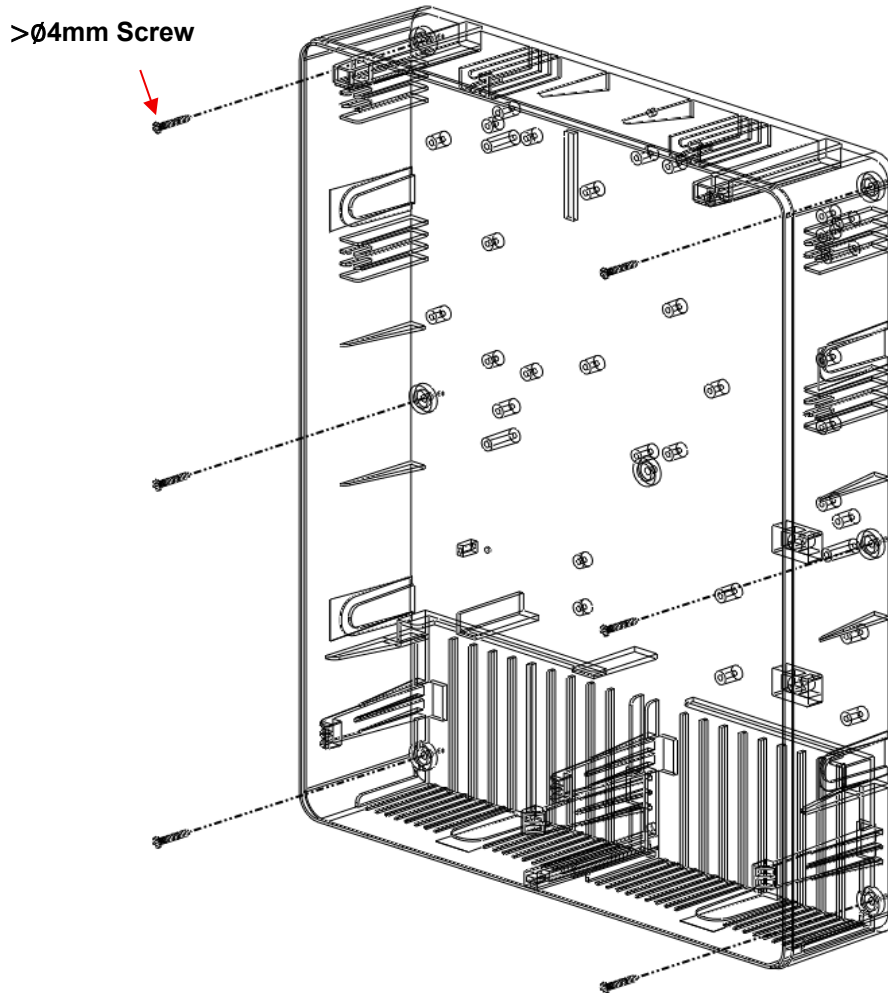

Figure 16: FA40 cabinet's mounting positions

3.1.3 Battery Mounting

The 2 x 12V 9Ah batteries can be mounted at the bottom of the FA40 in the two battery compartments shown below:

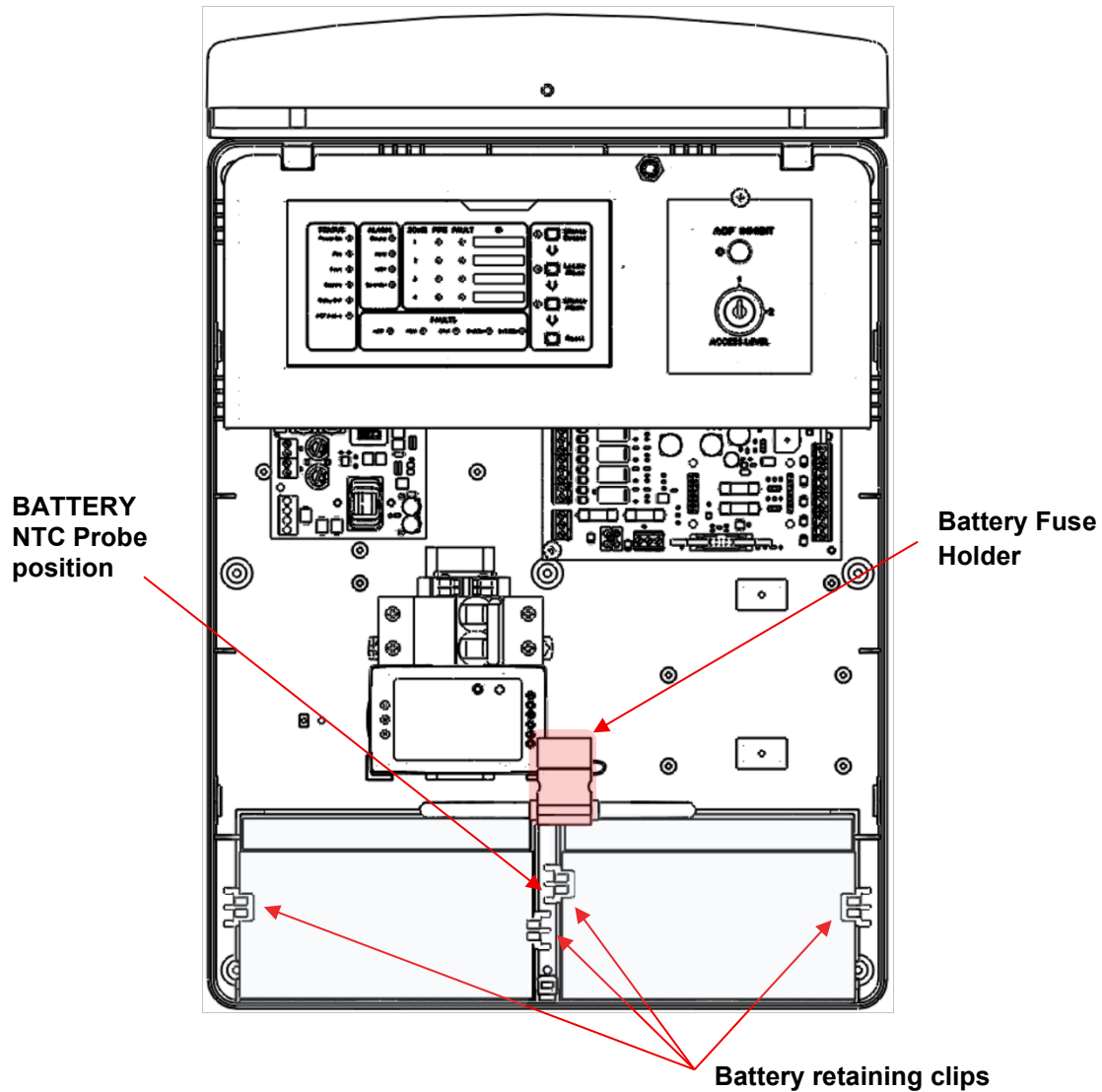

Figure 17: FA40 Battery Compartment

To install the batteries into the compartment:

- Align each battery with its lugs facing inward, toward the other battery.
- Gently push the retaining clips apart while sliding the batteries in evenly.
- Ensure both batteries are seated securely in place.
- Do not connect the battery lugs at this stage.
- Reconnect the fuse wires to the lugs once the batteries are properly positioned.
- Tuck the fuse holder inside the compartment.
- Leave the battery lugs disconnected until the FA40 unit has been powered on.
- Check the position of the battery NTC probe is secured between the two batteries.

Refer to §7.2 for information regarding maintenance of the batteries.

3.1.4 FA40 Battery Calculation

Battery calculation tool to be provided by your sales representative. Also available for download via the QR code located on the FA40 device.

3.1.5 FA40 Wiring

3.1.5.1 Mains Wiring

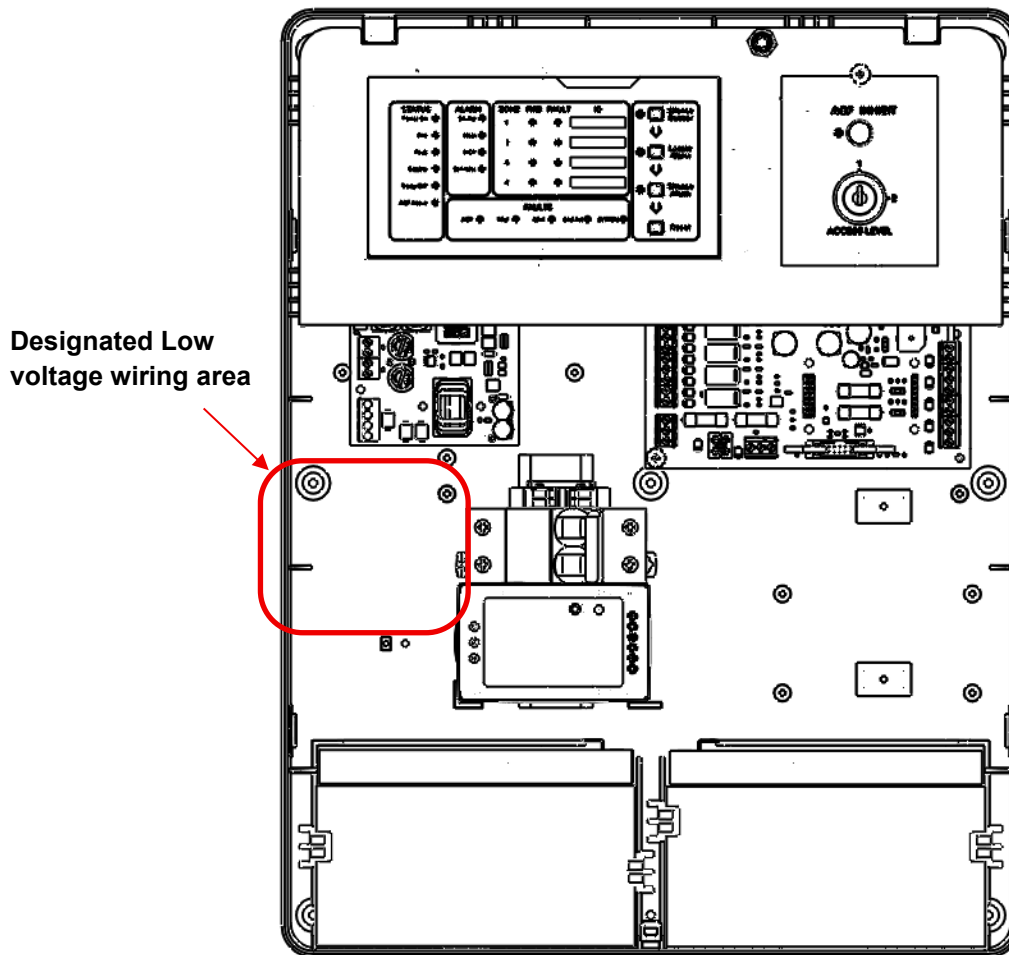

Figure 18: FA40 designated Mains voltage connection

If the low voltage wiring is recessed in the wall, cut a hole in the rear of the cabinet and bring the double insulated wiring into the FA40 cabinet as highlighted in the red area above.

If the low voltage wiring is wired along the surface of the wall, cut a hole on the left side of the FA40 cabinet and route the cable in through the highlighted red area above.

3.1.5.2 Field Wiring

Field wirings for Zones 1 – 4 and other
FA40 ancillary functions:

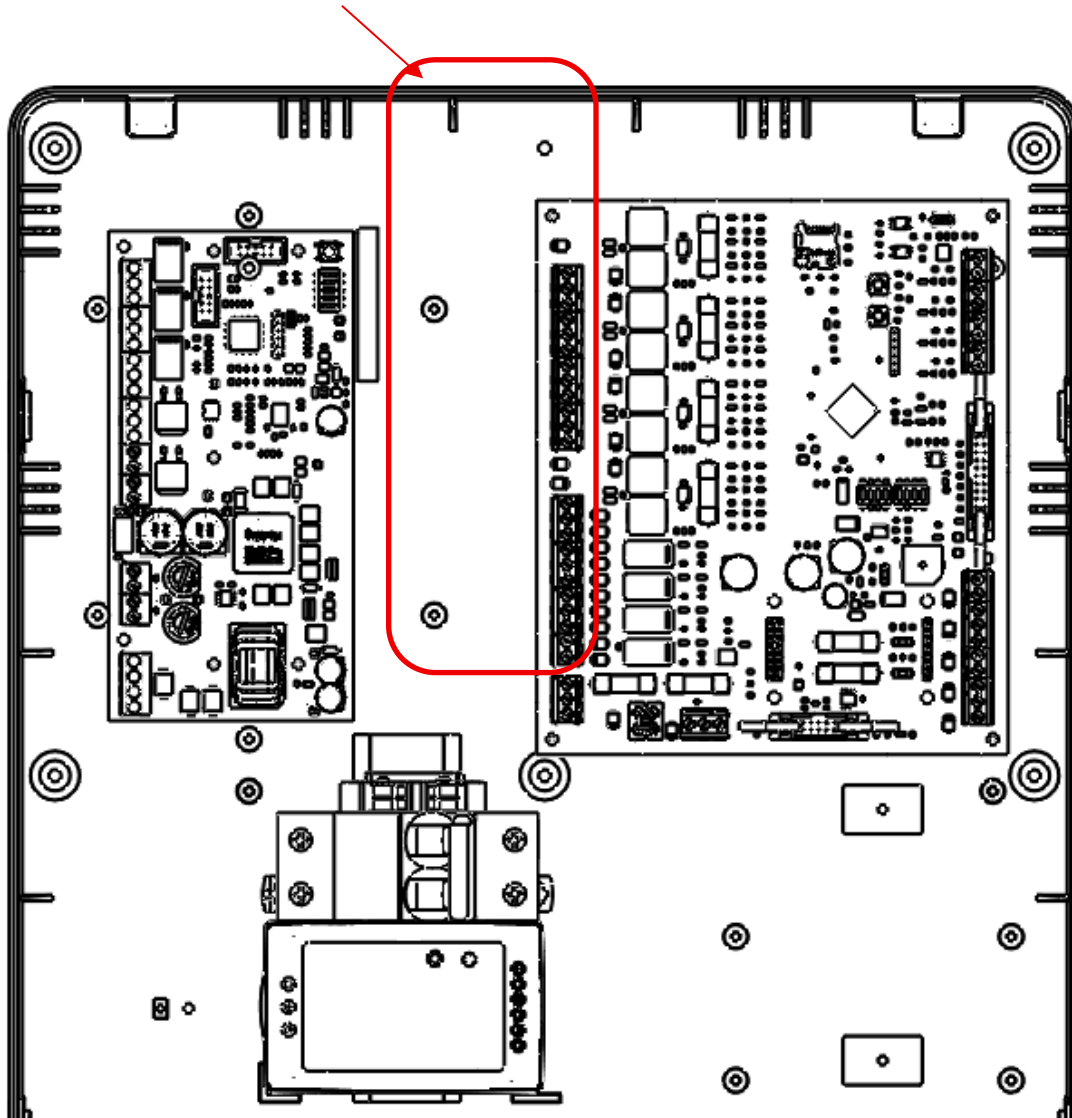

Figure 19: FA40 Zone wiring area

If the Zone wiring is recessed in the wall, cut a hole in the rear of the cabinet and bring the wiring into the FA40 cabinet as highlighted in the red circle above.

If the Zone wiring is wired along the surface of the wall, cut a hole on the top side of the FA40 cabinet and route the cable down through the highlighted red area above.

Note: Complete FA40 system setup §3.3.1 Initial system testing before wiring any of the zone field wiring into the panel.

Note: Ensure the ACF output is terminated with a 47k Ω EOL resistor for supervision.

3.1.5.3 Zone Wiring

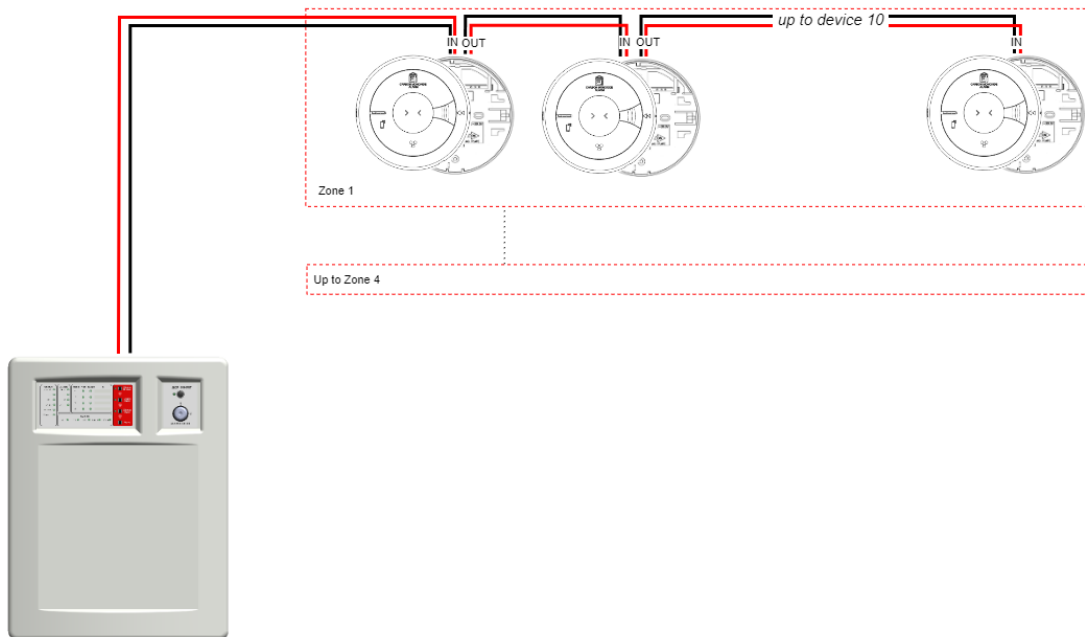

FA40 system is wired up in a daisy chain topology - out of FA40's Zone 1, into the first FA000 base, then out of that first FA000, and into the second FA000 base, and so on sequentially through each FA000 base up until the last base (Max 10). The last base must be designated the EOL. The FA40 is provided with 4 zones so each zone is wired up in an equivalent manner.

An example of zone wiring data has been provided below in Table 16: Zone wiring data example;. This zone wiring data must be provided for the commissioning of the system.

Earth connections for each zone output on the FA40's main board are provided for cables with shielding. If cables with shielding are used, tie off the shielding into the main boards zone terminals labelled "E".

For wiring instructions of the FA000 bases themselves, refer to §3.2.3 FA000 Wiring instructions below.



Fire Products & Solutions



FA40 Operation Manual

FireAlert Smoke Alarm System Iss 0.5

Table 16: Zone wiring data example:

Device Address (sequence)	Location:	Device Type:	Notes:
1	Lounge	FA016 (Smoke)	
2	Kitchen	FA014 (Heat)	
3	Ground floor hallway	FA016 (Smoke)	
4	Dining room	FA016 (Smoke)	
5	Bedroom 1	FA016 (Smoke)	
6	Bedroom 2	FA016 (Smoke)	
7	Bedroom 3	FA016 (Smoke)	
8	First floor hallway	FA016 (Smoke)	
9	Garage	FA014 (Heat)	EOL Termination network + EOL Dip switch.
10			Not used.

3.1.6 Adding Zone Descriptions

A template has been provided for clean and legible text to be added to each of the 4 zones. Please see our website for a downloadable copy. Follow the instructions on the template FA40 Zone ID Label_Template.



Figure 20: Insertion of the Zone description Label

3.1.7 Zone block plan

Note: Refer to AS1670.6 for information on the requirements

The front cover of the FA40 includes a flat area designed for attaching the building's Zone Block Plan as required by AS1670.6.

- **Dimensions:** 260 mm (Height) × 255 mm (Width)
- This area is intended for adhesives or double side taping of the plan.
- LX955 can be purchased from Brooks and have the Zone block plan engraved into it.

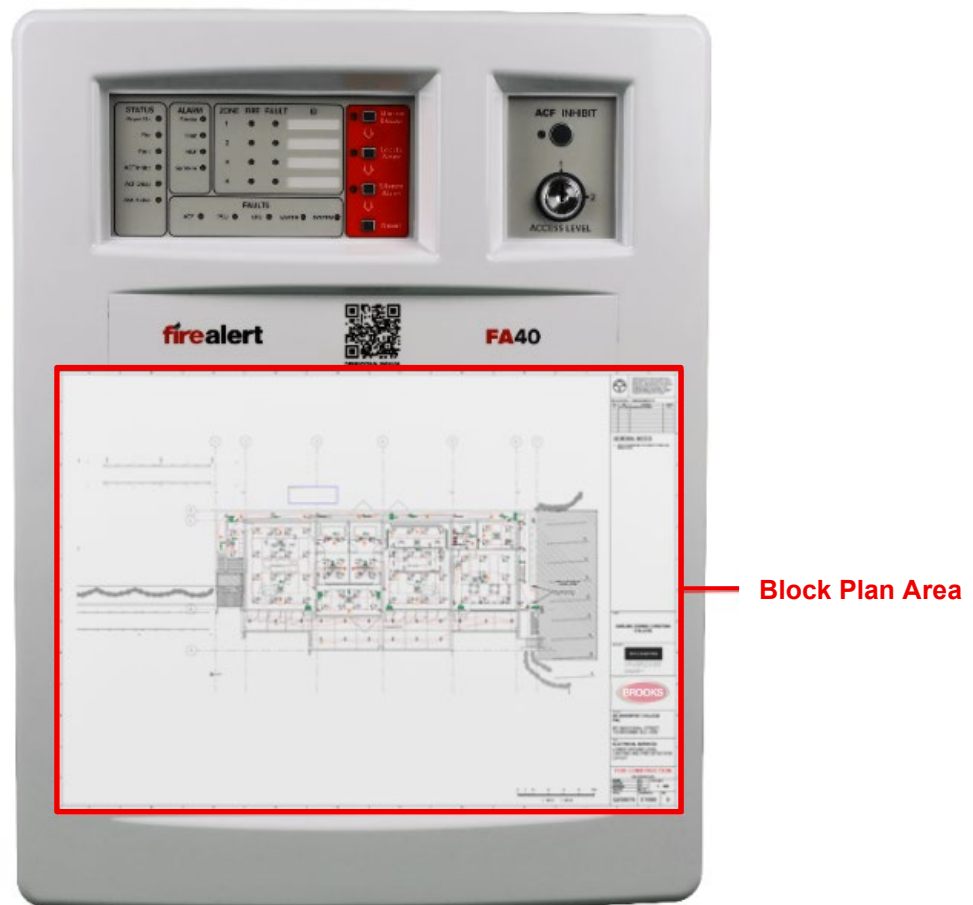

Figure 21: Zone block diagram area

3.2 FA000 Base Installation & Alarm Heads

The FA000 interface board comes with dedicated mounting base plate which is designed to use with all FA series Alarm heads.

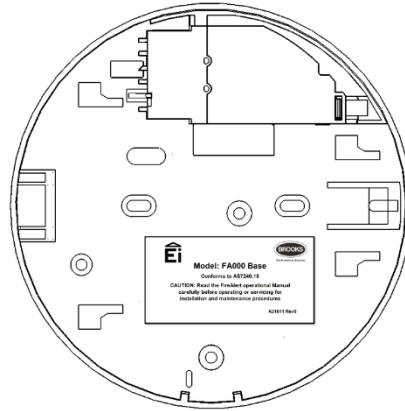

Figure 22: FA000 Mounting Base Plastic

3.2.1 Location

The locations for the any of the FA series alarms must comply with AS 1670.6, the building code of Australian, State and Territory legislation as applicable and instructions detailed in this manual.

3.2.1.1 Smoke and Heat alarms

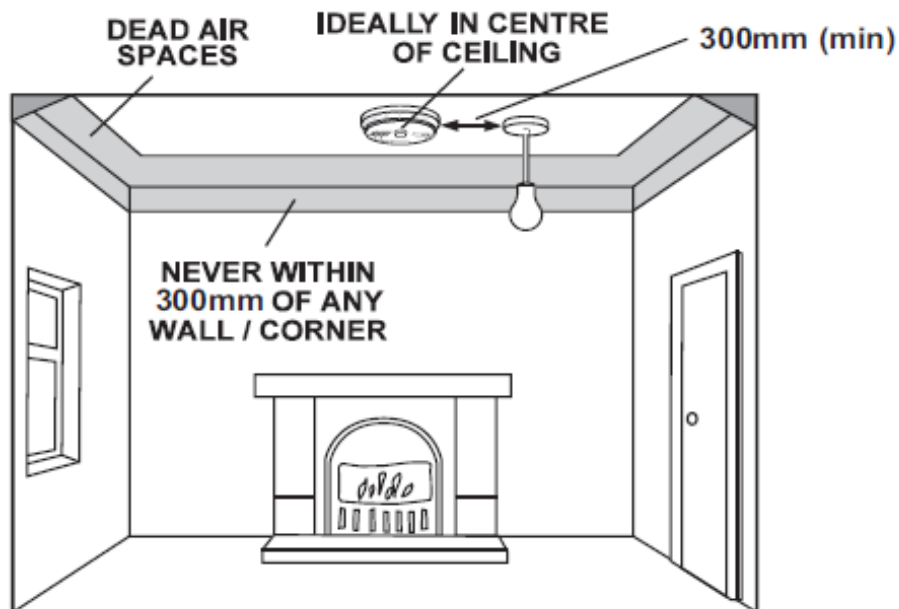

Figure 23: Smoke Alarm locations inside a room

Hot air rises and smoke spreads out, so a central ceiling position is the preferred location. The air is “dead” and does not move in the corners, Therefore Alarms must be mounted away from corners.

3.2.1.2 Locations to avoid (refer to AS1670.6 clause §3.2.3.7)

These locations can interfere with alarm performance or cause false alarms:

- Bathrooms, shower rooms, or damp/humid areas (due to steam or condensation)
- Very high or awkward areas (hard to access for testing or maintenance)
- Directly above sinks, cookers
- Near heaters, air conditioning vents, doors, windows, extractor fans, or wall vents (due to draughts or airflow changes)
- Where temperature may drop below -10°C or rise above 40°C
- In enclosed spaces (e.g. cupboards)
- Where the alarm may be obstructed (e.g. by curtains or furniture)
- In dusty or dirty areas (can block sensors or screens)
- Near paint, thinners, solvent fumes, or air fresheners
- Near dimmer-controlled lights or wiring (at least 1m away)
- Near fluorescent light fittings (at least 1.5m away; wiring at least 1m away)
- Open air spaces such as under crofts
- Damp or humid areas
- Surfaces with temperature differences (e.g. attic hatches)

Specific areas to avoid are:

- Insect infested areas. Small insects getting into the optical smoke sensor can cause intermittent false alarms. Insects and contamination on the heat sensor can increase its response time.
- Very dusty or dirty areas as dust build-up on the optical smoke sensor can impair performance. It can block the insect screen mesh and prevent smoke from entering the sensor. Dust build up can also increase the response time of the heat sensor.

3.2.2 Mounting

Mount the FA000 base in a suitable location as described above in §3.2.1 Location.

Fit the FA000:

- At least 300mm away from walls
- At least 300mm from any light fitting or decorative object which might obstruct smoke/ heat entering the alarm.

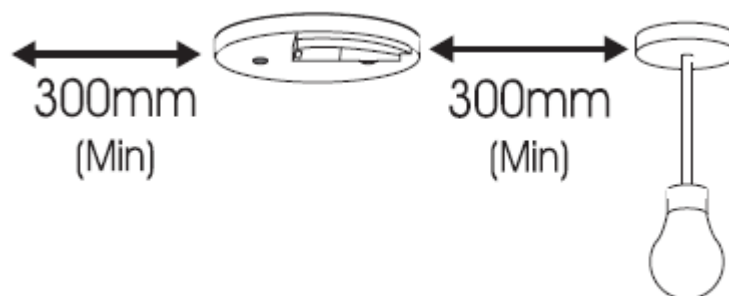
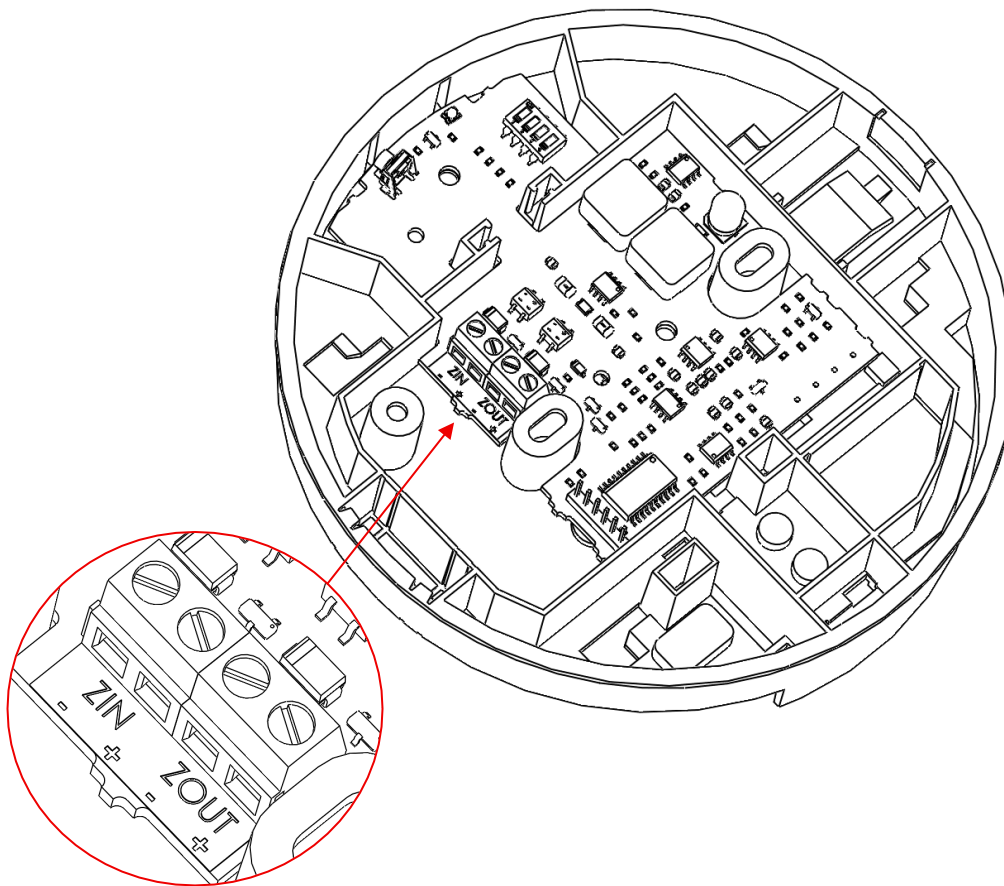

Figure 24: Minimum mounting distance from other objects

3.2.3 FA000 Wiring instructions

Once a suitable location has been found you can continue with wiring up the FA000 Base.

Note: Before connecting the interface card to the zone, ensure the panel is fully switched off and the panel batteries are disconnected.



ZIN = Input connection from the previous FA000 base or from one of the FA40's zone outputs. (Ensure polarity is correct).

ZOUT = Output connection to the next FA alarm.

The FA000 base uses DIP switches to identify the alarm type connected (FA014, FA016 or, FA024) to the FA40 RCIE. Switch 4 must be set to ON when the FA000 is the last device on a zone circuit (EOL).

Table 1 Dip Switch Settings of FA), refer to §2.2.2 Table 1 Dip Switch Settings of FA000 Base.

With the last alarm to be installed on the zone. **ZOUT** can be left unconnected.

3.2.3.1 Cable Properties/Selection

A fire alarm installation is a safety installation. It is important that the cables used within the installation comply with AS 1670.6. Fire alarm cables should, when possible, be installed away from other cables to avoid disturbances. Refer AS/CA S009 Installation requirements for customer cabling (wiring rules).

Note: Maximum cable length (total) from the FA40 RCIE to the last FA000 base, shall not exceed 100 meters per zone.

Brooks recommends the use of 1.5mm² twisted pair cables with properties:

- Conductor resistance 12.5 Ω/km
- Pair capacitance 88nF/km
- Pair Inductance 0.65μH/m
- 1.5mm² twisted pair (BROOKS BAC0898)

3.2.3.2 Wiring from within the ceiling

If the wires are recessed within the ceiling, cut a small hole within the ceiling and bring the wires in through the opening flap of foam on the rear of the FA000.

3.2.3.3 Wiring along the surface of the ceiling (Surface ducting)

If the wires are being brought along the surface of the ceiling, the FA000 has a removable section as shown in the figure below, in red:

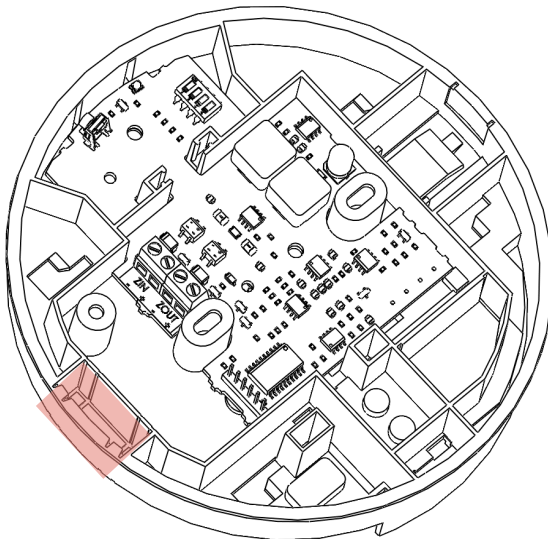

With the section removed cables can be routed in from the side:

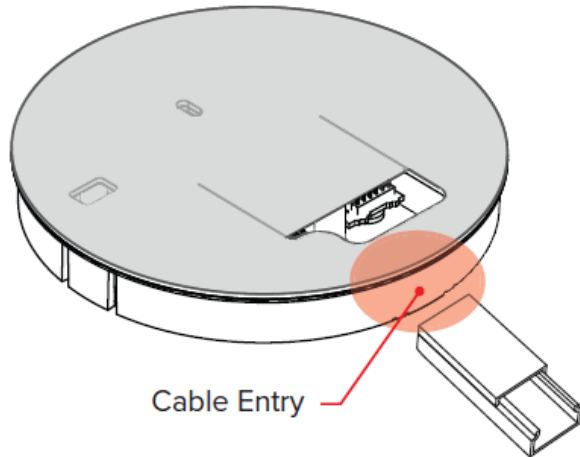

3.2.3.4 Mounting FA000

Two slots have been provided on the FA000 base to accommodate up to No. 6 wood screws for attaching the FA000 base to a wall

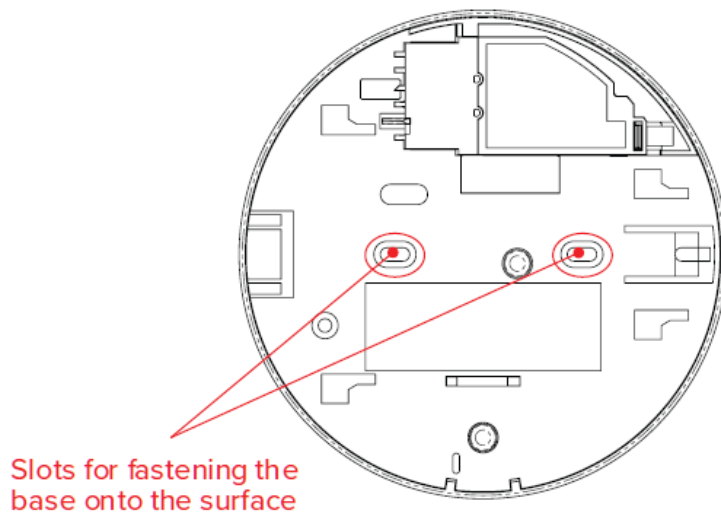

3.2.4 Connecting FA Alarms to the FA Base

Note: Before connecting the FA Alarm to the base, ensure the dip switches have been correctly configured to suit the type of alarm to be installed. Refer to §2.2.2 Head Configuration, for an explanation.

Once the FA000 Base has been installed, and wired up into the system, slide the alarm onto the base until you hear a click.

Slide on the Alarm

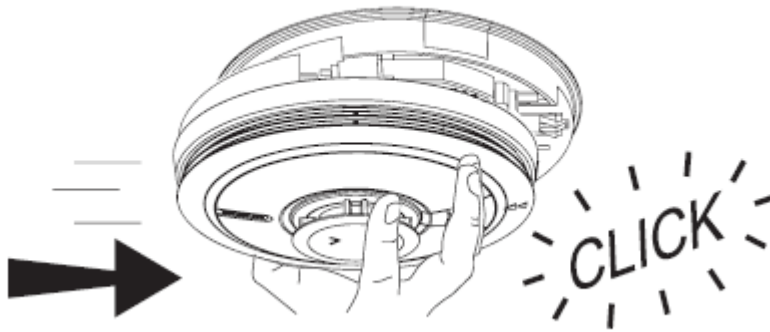

When the FA40 system is powered on you can confirm the head is operational by the illumination of its green indicator as well as pressing the test/hush button on the FA alarm itself.

3.2.5 Removing FA Alarms from the FA Base

Note: Disconnect power from the FA40 panel before removing FA alarms:

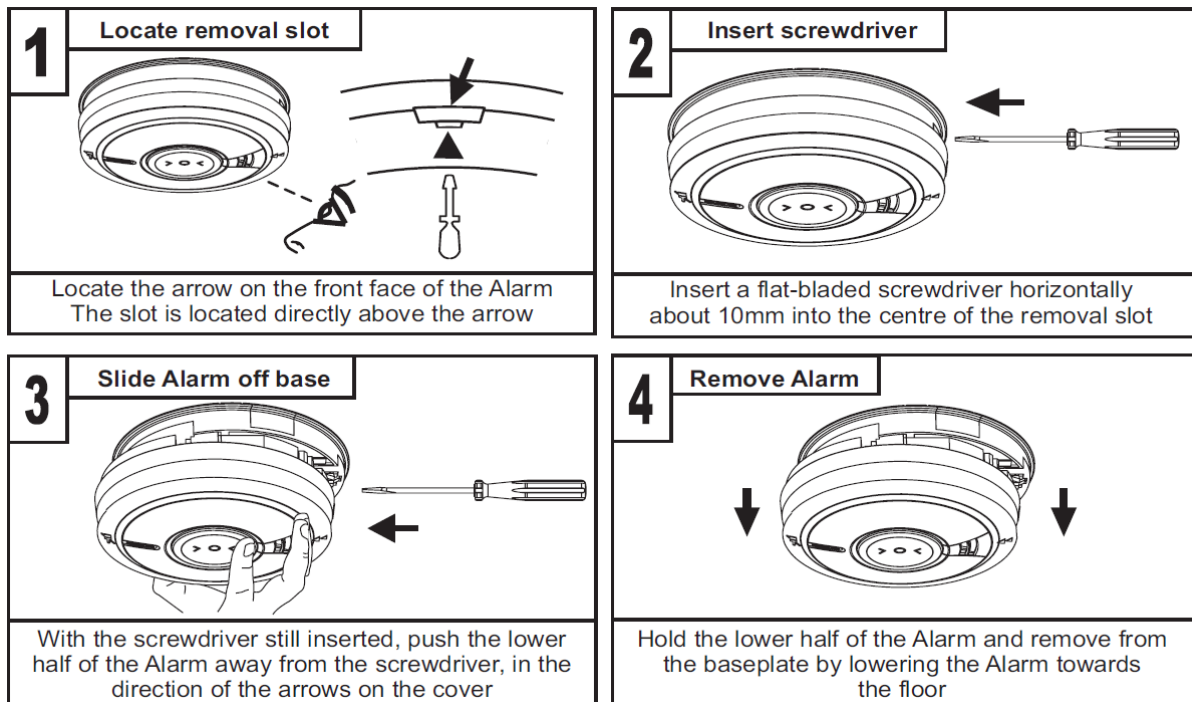

Figure 25: FA Alarms removal procedure



3.3 FA40 System Setup

Once the cabinet is mounted and secured in place with the outer cover, the following power up procedures must be followed.

Note: Do not terminate any zone field wiring until the FA40 Initial system testing has been performed.

- Insert the 003 Key and turn to **ACCESS LEVEL 2**.

Note: Opening the RCIE cover, without **ACCESS LEVEL 2** will activate **SYSTEM FAULT**. Refer to §4.2.6 & §4.3 for details on access levels and fault conditions.

- Ensure the Mains isolator is in the **OFF** position before connecting the incoming mains power into the isolator.
- Switch **ON** the mains power using the isolator inside the cabinet.
- Connect the batteries to the designated battery leads.
- The FA40 will startup and each zone fault will begin flashing as it checks and initializes each zone, once complete, §3.3.1 Initial system testing can be followed below.

3.3.1 Initial system testing

Before connecting field device wiring, perform the following checks to verify system functionality:

- Ensure only the green **POWER ON** LED is illuminated with the 003 Key Switch set to **ACCESS LEVEL 2**. – (NORMAL OPERATION)
- Press the **RESET** control, then release. All display indicators should illuminate, and the internal buzzer will sound once.
- Switch **OFF** the incoming mains isolator. The **PSU FAULT** indicator should illuminate steadily, the **GENERAL FAULT** indicator should flash, and the internal buzzer will sound. The **SILENCE BUZZER** control indicator will flash, indicating the function is available. Press **SILENCE BUZZER** to mute the buzzer; the indicator will become steady state.
- Switch back ON the incoming mains isolator. The system should return to normal operation.
- Disconnect the batteries, within 30 seconds, The **PSU FAULT** indicator should illuminate steadily, the **GENERAL FAULT** indicator should flash, and the internal buzzer will sound. The **SILENCE BUZZER** control indicator will flash, indicating the function is available. Press **SILENCE BUZZER** to mute the buzzer; the indicator will become steady state.
- Re-connect the battery, within 30 seconds, The system should return to normal operation.
- Press the **ACF INHIBIT** control. The corresponding control indicator should illuminate, confirming that the ACF output is inhibited. Additionally, the **ACF Inhibit** indicator under the general status column should also be illuminated.
- Press the **ACF INHIBIT** control again, the system should return to normal operation.
- Disconnect the batteries and switch OFF the incoming mains isolator.
- The system is ready for field wiring and alarm devices setup, refer to §3.3.2 below.



3.3.2 Alarms Devices Set-up

Note: Care needs to be taken to set the system up correctly the first time. If an issue arises during the initial auto addressing sequence, manually resetting devices back to base address 0 will be required (factory reset §).

The FA000 bases come programmed with a base address zero, upon first power up and initial startup communications with the FA40 panel the FA000 base will be programmed sequentially with an address from 1 to 10, depending on number and wire sequence of devices on the zone. You therefore cannot interchange and swap FA000 bases without factory resetting the FA000 base as described in §2.2.4. If the zone needs to be reconfigured, by either adding or removing devices, follow the guidance as mentioned below in §3.3.3 FA40 Zone reconfiguration guidance:

3.3.2.1 Device Configuration

The FA series alarms are mounted onto the Easi-fit FA000 base, which facilitates communication with the FA40 RCIE. The FA000 base includes an interface card that connects each alarm to the corresponding FA40 zone circuit. These bases draw primary power from the RCIE zone circuit, which also charges FA alarms integrated non-removable standby batteries.

The FA000 base uses DIP switches to identify the type of FA alarm device (FA014, FA016, or FA024) connected to the FA40 RCIE.

By default, all DIP switches are set to the **OFF** position, configuring the device as an **FA016 (Smoke)** alarm without EOL.

If the FA000 base is the **last device** on a zone circuit, **switch 4 must be set to ON** to designate the end-of-line position and the SUB1055–FA EOL Device shall also be inserted into the ZOUT connection, refer to §Figure 28: SUB1055 – FA EOL Device. below.

Note: The last device in the zone must have dip switch 4 set to **ON**.

If the EOL switch is not set correctly, either by not setting it, having more than one set on a zone or not setting it in the correct position within the zone, A zone fault will be displayed immediately after startup.

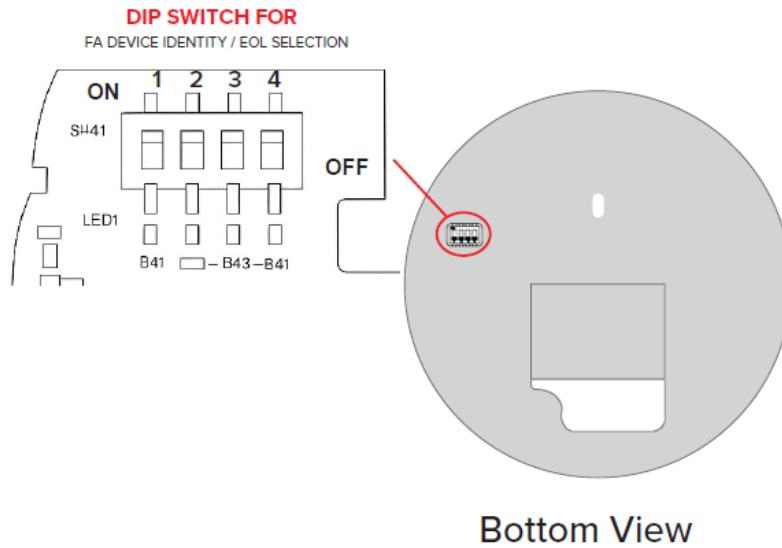

Figure 26: FA000 Base DIP Switch

Refer to §2.2.2 Head Configuration for configuring the FA000 base to match the alarm's head type correctly. If the DIP switches are not configured properly the panel will not respond correctly.

3.3.2.1.1 SUB1055 – FA EOL Device

From factory the FA40, comes with 4 x SUB1055 pre-installed in each of the FA40 zone outputs:

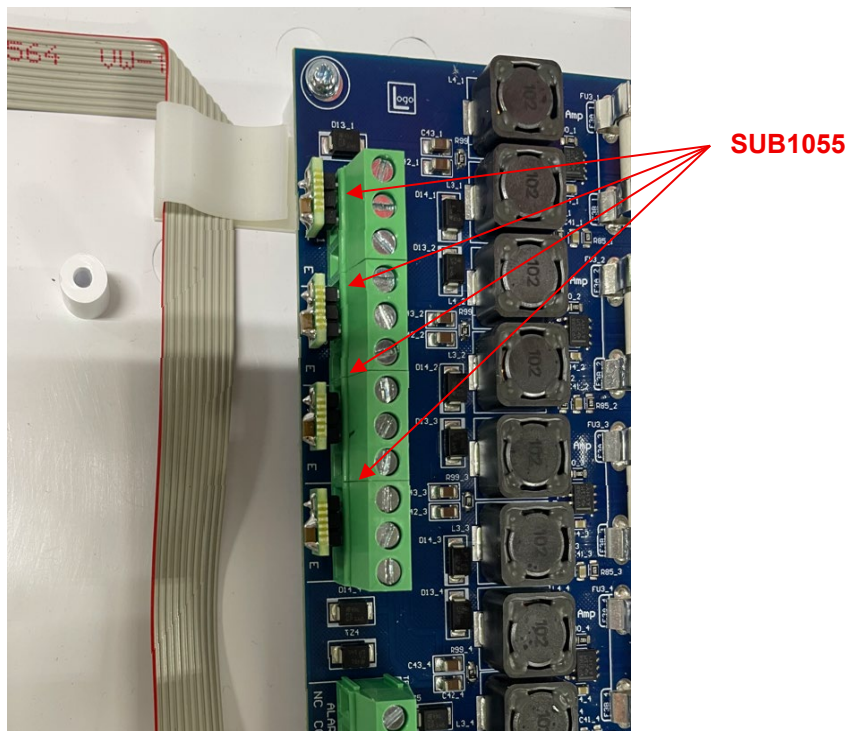

Figure 27: 4 x SUB1055 inserted into each FA40 Zone

When FA alarms devices are connected into a particular zone, unscrew the SUB1055 – FA EOL device from that zone and insert it into the ZOUT of the last device on the Zone, remembering to also enable the EOL switch on that device. Example below shows the EOL switch and EOL device being connected to an FA000 base.

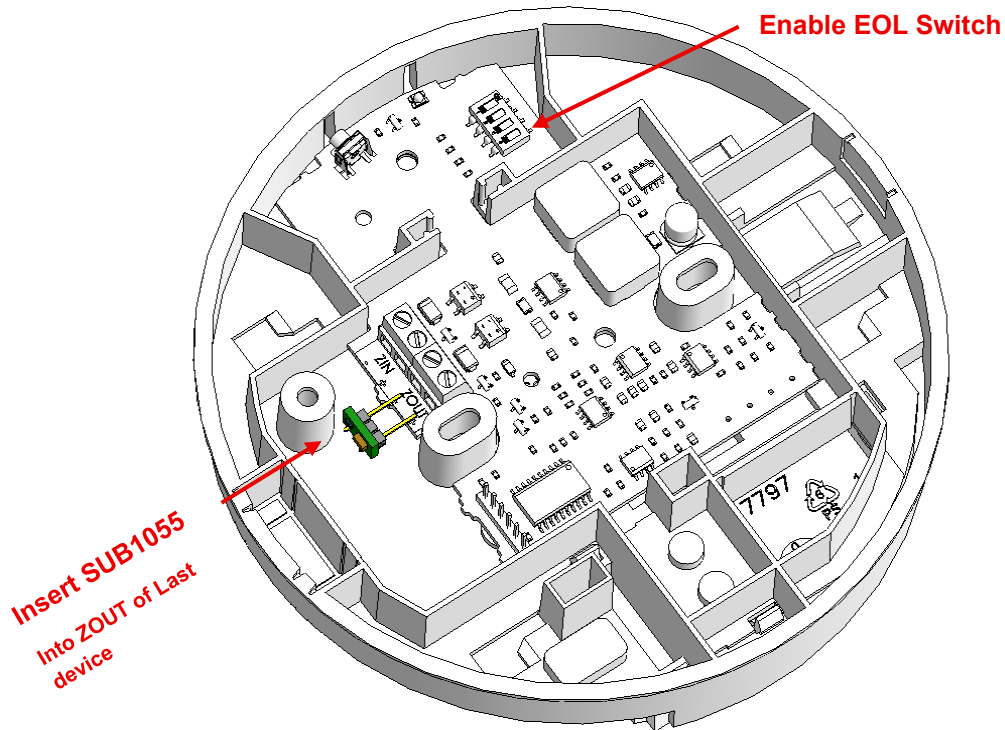

Figure 28: SUB1055 – FA EOL Device.



3.3.2.2 Alarm devices auto addressing sequence:

Once §3.3.1 Initial system testing has been conducted. Remove power from the FA40 by flipping the main isolation breaker and removing the battery connections.

Ensure the zones and alarms (FA000 Bases and FA Alarm Heads) are configured and wired correctly. Take note of the order when installing the FA000 onto the ceiling as the order the heads are wired in will be the order the devices addresses will be programmed as [1 to 10].

- Terminate all zone wiring into the FA40 panel.
- Switch on the mains isolator.
- Connect the battery leads.
- The FA40 will start an initial auto addressing sequence to program all unaddressed devices found on each zone.
- The zone fault LED will start flashing indicating which zone it is currently being configured.
- Once the zone is configured it will move along to the next zone until all 4 zones have been configured and correctly identified.

Note: On the very first startup and if a lot of devices are connected to each zone, the startup sequence will take some time, please do not interrupt or stop the startup sequence during this time. Wait until the front panel has completely started up and the system has reverted to normal operation with only the green power status indicator held solidly on.

- If for whatever reason during the initial startup sequence the zone was incorrectly configured and a Zone fault was displayed, follow the trouble shooting guide below.

3.3.2.2.1 FA40 initial auto addressing trouble shooting guide:

If a zone fault is displayed immediately after the startup sequence completes, Check for the following issues:

Check/Investigation:	Required Action:
Any FA000 bases amber status indicator held solidly on.	Factory reset every FA000 on that zone then repeat the FA40 initial auto-addressing startup sequence.
FA series alarm heads not connected to FA000 base.	Ensure every FA000 base has a FA Alarm head connected to every base, or a tamper fault will be detected. Once the FA series alarm head is reattached the zone fault should automatically clear.
EOL device not enabled or not positioned correctly within the zone.	Ensure only the last FA000 base on any zone has the EOL dip switch set. Then reinitialize the complete FA40 system to confirm.

3.3.3 FA40 Zone reconfiguration guidance:

The following examples and guidance are provided for handling different zone reconfiguration scenarios. If the guidance is not followed, the system may not function as required.

The following is an example of a zone circuit that could need to be configured.

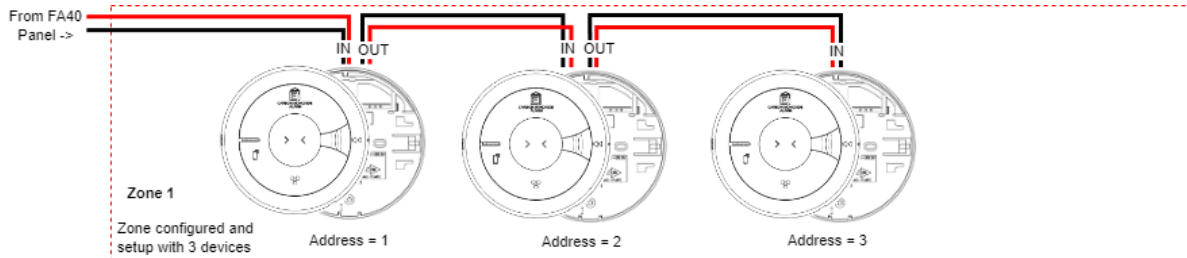
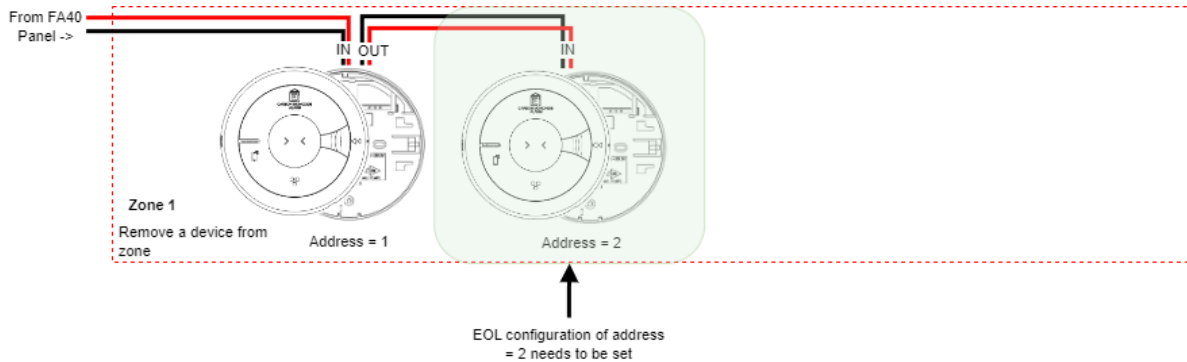

Figure 29: Zone 1 Reconfiguration Guidance

Depending on whether you want to remove, append or insert a device into the zone circuitry, follow the specific instructions below:

3.3.3.1 Removing the end device from the zone:



Using Figure 29: Zone 1 Reconfiguration Guidance as reference, If a device on the end of the zone was removed, for example device address 3 is remove, You will need to enable the EOL configuration dip switch and move the SUB1055 FA EOL Device to the last device on the zone and reinitialize the FA40.

3.3.3.2 Removing a device from the middle of the zone:

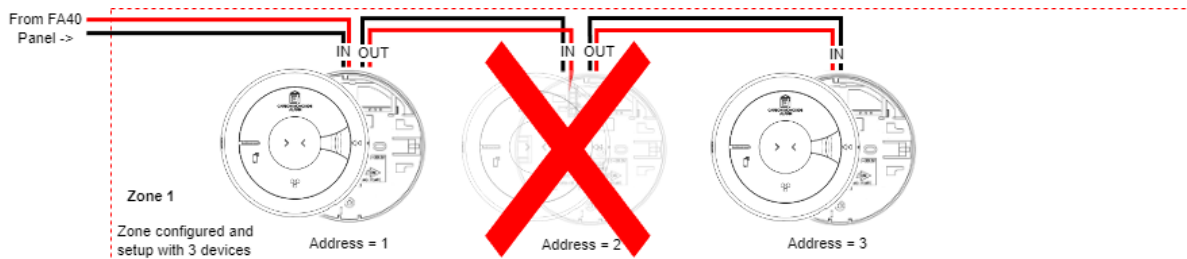

Using Figure 29: Zone 1 Reconfiguration Guidance as reference, If a device is removed from the middle of the zone circuit. First factory reset device address 3 to default address 0 before dengerizing the FA40. The wiring of the zone must then be rewired correctly with ZOUT from device address 1 must be connected to ZIN of device address 3. Upon the complete FA40 reinitialization the initial

device address 3 will be reprogrammed as device address 2. Both the SUB1055 - FA EOL Device and EOL dip switch setting must remain on the last device on the zone.

3.3.3.3 Adding a device to the end of the zone circuit:

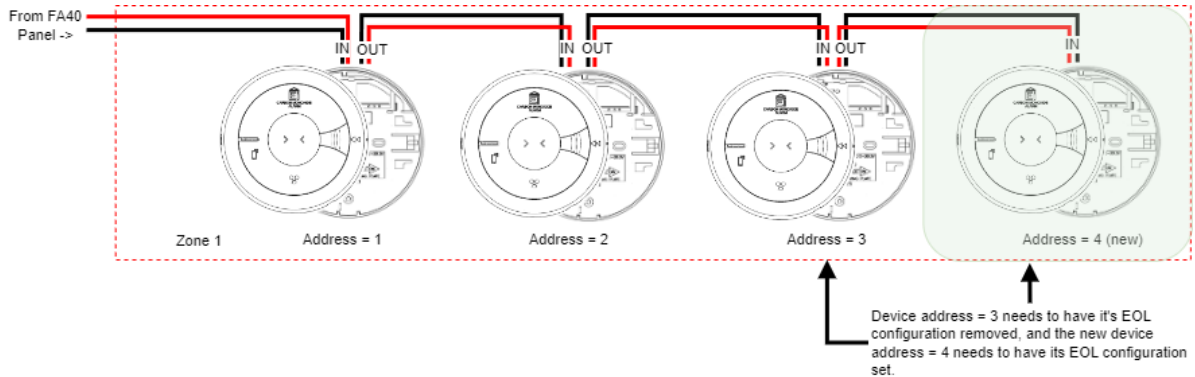

Using Figure 29: Zone 1 Reconfiguration Guidance as reference, If an additional device is added at the end of the zone circuit. The EOL dip switch selection on device address 3 must be deselected and the EOL dip switch selection on the newly added device must be selected. In addition the SUB1055 FA EOL Device must be installed into ZOUT of the last FA000 base on the zone. After a reinitialization of the FA40 the newly added device will be automatically added to zone 1 of the FA40 and given device address 4.

3.3.3.4 Inserting a device into the middle of the zone:

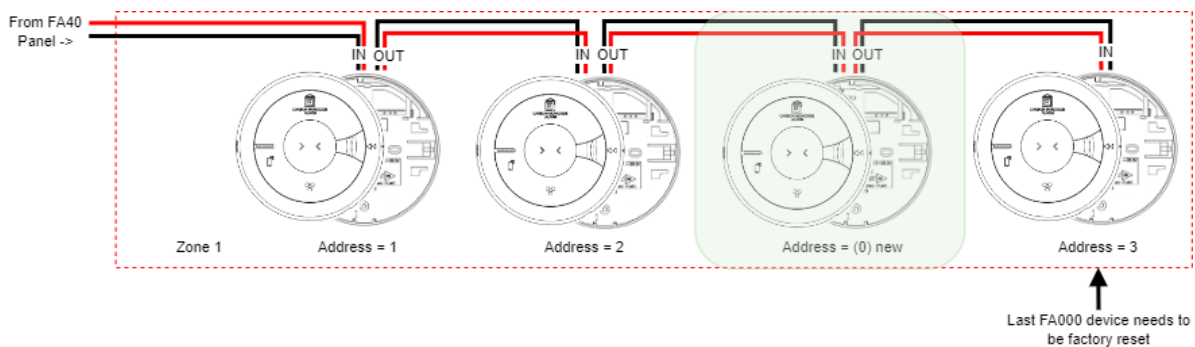

If you are required to insert a device into the middle of a zone, you will need to ensure correct rewiring of the zone circuit in a sequential order. As well as you will need to factory reset each device downstream of the newly added device. Using Figure 29: Zone 1 Reconfiguration Guidance as reference, if you are needing to insert a new device into the zone between device address 2 and device address 3. Device address 3 must be factory reset. ensure the last device always contains both the SUB1055 FA EOL Device as well as the dip switch is selected as EOL.

To ensure the zone is properly reconfigured correctly, please follow the following steps correctly.

Note: If you do not know the sequence of the device's you must follow the steps #1 to #10 below to figure out sequence and addresses of device on the zone, if you know each device's address and therefore sequence you can skip to step #11 below.

You can also confirm the address of a FA000 by holding down the reset button for >2 seconds, but less than 5 seconds, refer to §2.2.4 for further details.



Steps to perform:

1. Starting at the FA40 panel, insert the 003 key and turn to access level 1
2. Remove the front cover.
3. Turn off the mains isolator
4. Disconnect the batteries.
5. Wait >10 seconds for the system to completely de energize.
6. Switch the mains isolator back on.
7. Reconnect the batteries.
8. Once the panel has finished initialization, you have ~10 minutes to go around to each device on the zone and read off the blinking pattern of the device to identify them on the zone. (Remember the zone is sequential addressed). Refer to §2.2.3 for further information on how to read the FA000 blinking pattern.
9. When you find the device that you are looking to insert a new FA000 device between, take note of the address you are pulling the ZOUT connection from to insert the new detector.
10. With the address now found and before rewiring the new device into the zone, look for all downstream device's and mark any devices with a higher address than the device's address found in previous step 3.
11. For any device's that have a higher address, reset that device by holding down the reset button on the device for greater than 5 seconds, until the FA000 status LED changes to solid amber. Refer to §2.2.4.2
12. Once all higher address devices have been factory reset. Completely de-energize the FA40 panel, including both mains isolator and batteries again.
13. With the power to the FA40 completely removed, you may now rewire the zone circuitry, inserting the new device into the zone. Remember to reconfigure the FA000 base to match the FA series head to be connected.
14. After the new device is installed correctly, reinitialize the FA40 system and wait for each zone to initialize.
15. After initializing, confirm the newly added device gets correctly addressed, as well as all downstream devices by inspecting the blinking pattern (§2.2.3) of the FA000 status LED.



4 FA40 OPERATION

4.1 ALARM TYPE

In the event of a fire, the alarm may be triggered by smoke alarms, heat alarms, manual call points, sprinkler alarm switch activation or dedicated input modules. Each alarm type is clearly displayed on the FA40 RCIE display.

When a fire alarm is activated within a zone, the corresponding zone indicator and alarm type will be displayed. Where the FA40 is connected to a residential sprinkler system the sprinkler input must be on its own zone. This feature of the FA40 display helps occupants quickly identify the nature, location, and urgency of the alarm, supporting an appropriate evacuation response.

Alarm priorities are classified as follows:

- **Priority 1 (P1):**
Includes heat alarms, manual call points, and sprinkler alarms. Activation of any P1 alarm will immediately trigger all zones into a general alarm condition throughout the building or dwelling. All associated alarm points will be active.
- **Priority 2 (P2):**
Smoke alarms only. Dependent on whether the zone configuration is for general alarm or independent zone alarm, activation of a P2 alarm input will either trigger a building wide “general” alarm condition or a “zone specific” alarm condition. Outputs will follow the zone configuration format.

4.2 FA40 Controls

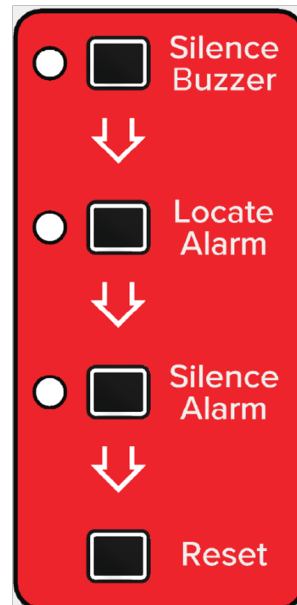

Figure 30: FA40 Alarm Condition Controls

In the fire alarm condition, the four controls within the red area enable the management of the FireAlert system during an active fire event. Except for the “**silence buzzer**” control, all other controls are only available at access level two.

To ensure a consistency of response these controls are interlocked and must be pressed in sequence. The LED indicator associated with each control illuminates in sequence to guide the user through the correct response procedure. Each control only becoming active when it is preceded by the correct operation of the previous control. For example, when the FA40 enters the alarm condition the “**Silence Buzzer**” LED flashes guiding the user to select this control. Once pressed the silence buzzer LED goes steady state and the “**Locate alarm**” indicator flashes, again guiding the user to select this control. This in turn is followed by the “**Silence alarms**” control.

§4.2.1 - §4.2.4 below, explain the functions of each control in more detail.

4.2.1 SILENCE BUZZER

The integrated buzzer in the FA40 RCIE will sound for any fire alarms, or any faults that occur within the system to attract the user to the FA 40 RCIE. Press the Silence Buzzer control to silence the buzzer. When the control is pressed, the buzzer will be muted, and the Silence Buzzer indicator state will change from flashing to steady.

In case of a new alarm condition or new fault condition, Both the Buzzer and Silence Buzzer indicator will automatically resume sounding and flashing again.

After the buzzer has been silenced during fault conditions, the buzzer and the Silence Buzzer indicator will return to normal automatically when these faults are corrected/ serviced.

4.2.2 LOCATE ALARM

The Locate Alarm function becomes available while the FA40 is in an alarm condition. Depending on zone configurations (see §2.3.2.4), alarms will sound accordingly.



During an alarm, after pressing the Silence Buzzer button, the Locate Alarm indicator will begin flashing. This indicates the system is ready for you to activate the Locate Alarm control.

Pressing the Locate Alarm control helps identify the source of the alarm by silencing all alarms devices except those that triggered the active alarm condition. This allows the user to quickly identify the area of fire origin and thereby assists in determining the fire response required. Once pressed, the Locate Alarm indicator will change from flashing to steady ON.

Note: Once the source alarm(s) is identified, it is necessary to carry out proper investigation before you Silence all the alarms.

4.2.3 SILENCE ALARM

The Silence Alarm control is used to silence all audible alarm outputs. This control must only be used when the cause of the alarm has been investigated, and it has been determined there is no actual fire event. This control effectively stops the occupant warning and hence the evaluation of the building or dwelling. When pressed, all alarms will be silenced. The source alarm(s) device and RCIE will enter into 10 minutes silence period by showing steady ON Silence Alarm LED at the FA40 RCIE.

The general fire indicator, Alarm Type indicator and the respective Zone fire indicator will remain flashing throughout this silence period. If no additional alarms are detected, and the 10-minute period expires, the system will automatically return to normal operation.

4.2.4 ALARM RESET

Note: The RESET control at FA40 RCIE does not cancel the 10-minute period of previously silenced FA alarms.

The FA40 does not currently have a Zone Latching option configuration, therefore there is no manual reset control required to clear the FA40 from the alarm condition, when the alarms clear in the field the FA40 panel will stop displaying that zone is in alarm. If more than 1 alarm is active in a zone, all active alarms will need to clear before that zone's indicator will be cleared.

4.2.4.1 FA40 UI Indicator test

When the reset button is pressed, all LEDs on the display will illuminate, and the internal buzzer will sound for approximately 1 second. This test can be performed at any time while access level 2 is granted.

4.2.5 ACF INHIBIT

The ACF Inhibit control only becomes available when access level 2 is gained. When pressed, the ACF output will not function. Refer to §5.1.5 for an explanation on the function test.

After inhibiting the ACF output, you can restore this function by pressing the ACF inhibit control again.

Note: Always restore the ACF output after maintenance to ensure proper system operation.

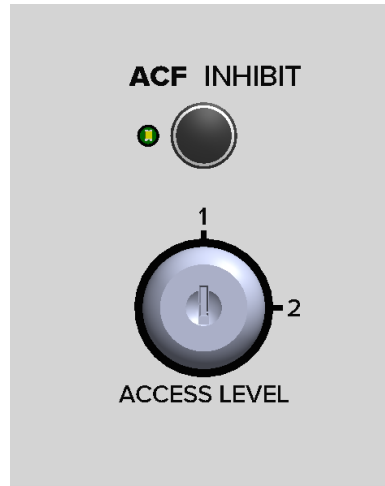

Figure 31: Access level and ACF Inhibit Control

4.2.6 ACCESS LEVEL

FA40 RCIE has 4 user levels as defined per AS 7240.2

User Level	User Level name/type	Required action/equipment	Access to
1	None	None	View indications and Silence Buzzer
2	Service/Emergency personnel	003 Key Required	FA40 Controls
3	Trained and authorised service personal	As per 2 + Unscrew cover of the FA40 and remove.	Internal components of FA40
4	Systems Engineer	USB micro-B and Programmer	Reconfiguring Firmware



Note: A 003-fire services key is required to gain access to level 2 onwards

Table 17: System Controls vs Access level

Controls	Function	Access Level Required
SILENCE BUZZER	Stop RCIE internal buzzer	Level 1 (Basic)
LOCATE ALARM	Identify alarm source	Level 2 (Full)
SILENCE ALARM	Silence all FA Alarms	Level 2 (Full)
RESET	Clear all alarms and reset devices	Level 2 (Full)
KEY SWITCH	Toggle access level 1 & 2	Physical 003 key
ACF INHIBIT	To inhibit Ancillary Control Output	Level 2 (Full)



4.3 FAULTS

In case of a fault condition, the following will happen in the RCIE:

- The internal buzzer will sound
- The general fault output will be activated
- The general fault indicator will flash
- The respective fault indicator will flash

The buzzer can be silenced during fault conditions. But any new faults occurrences will resound the buzzer after being silenced.

Below follows a list of all faults and its description.

Table 18 List of all faults and their descriptions of FA40 RCIE

PSU fault
This fault represents the Mains incoming is disconnected, charger voltage low/high, backup batteries are disconnected, backup batteries voltage low/high, and batteries internal resistance is high
System fault
This fault represents an error in system modules. Such as; communication between the main control module and other modules, or the FA40 RCIE cover is removed without authorised user access.
CPU fault
This fault represents CPU failure at main control module/ display module and power supply supervision module.
Earth fault
This fault represents an Earth fault is detected in the control unit. Check all cables (for damage, etc.) connected to the FA40 RCIE.
Ancillary Control Facilities fault
This fault represents the ancillary control O/P circuit supervision fault at main control module. Such as; open circuit/ short circuit, or missing End-Of-Line device.
Zone faults
This fault represents the respective zone circuit supervision fault. Such as; zone fuses blown, open circuit/ short circuit/ FA alarm head removed, missing or incorrectly placed End-Of-Line(EOL) device during startup. Zone faults are monitored individually.



5 FUNCTIONAL TESTING

5.1 GENERAL

Before commencing testing your FireAlert Smoke Alarm System, it is important to ensure that the equipment interfaced to the system has been isolated using the suitable isolate facility either in the panel or on the equipment itself. It is also important to notify occupants and the monitoring centre.

5.1.1 Pre-Testing

A visual inspection should be performed of the system to ensure no physical damage, loose wires, or components inside the enclosure.

- Enclosure visual check
- All boards firmly mounted
- All Configuration DIP Switches correctly set
- FA Alarms wiring correctly terminated to main boards zone circuits
- All 230V_{AC} mains cables correctly terminated
- All ribbon Cables firmly secured
- EOL configuration are correctly set on all of the last devices in a zone
- Manuals and instructions supplied
- Ensure Key switch in the access level 2 position
- Turn ON the mains isolating switch
- Power on LED illuminates
- Connect batteries
- Ensure all LEDs are 'OFF' except Power on LED
- Ensure no Smoke / Heat Alarm is sounding
- Check charger output voltage 28.5V DC



5.1.2 Zone Alarm Test:

Check that the green power indicator is 'ON' on all FA Alarms within the zone. If it is off, check the zone circuit, fuses, wiring and RCIE etc.

Ensure the FA40 RCIE in normal mode and only "Power On" (Green) LED is on.

Press the test button of any FA Alarms within the specific zone for up to 10 seconds and ensure that the Alarm sounds and releases. Pressing the test button simulates the effect of smoke and/or heat and FA40 RCIE goes into alarm mode.

- General Fire LED will flash
- The respective Zone Fire LED will flash
- The alarms type such as Smoke/Heat/MCP or Sprinkler LED will flash based on the device activated/tested
- All the FA Alarms connected to RCIE zones will sound. If common alarm Dip Switch setting for the respective zone is selected at the main control board, the whole system will sound.
- Priority 1 (P1) Alarm - voltage free contact changes based on Alarm type (Heat/ MCP & Sprinkler)
- Priority 2 (P2) Alarm - voltage free contact changes based on Alarm type (Smoke)
- Ancillary Control Function Output - supervised 24Vdc will be activated. The status of Alarm Output will be indicated by ACF Active LED illuminated at the front of FA40 RCIE.
- Built-in RCIE buzzer will sound
- Release test button and RCIE and all other FA Alarms resume back to normal.

Repeat **Zone Alarm Test** for rest of the zones.

5.1.3 Zone Fault Test:

Zone Fault Test can be performed by doing any of the following;

- Remove a FA Alarm head from the base
- Create open circuit across the zone
- Remove zone line fuse at the main control board.

The FA40 RCIE will response as follows;

- General Fault LED will flash
- The respective Zone Fault LED will flash
- Built-in RCIE buzzer will sound
- General Fault – voltage free contact changes over

Press Silence Buzzer button at RCIE, the buzzer stops sounding and Silence Buzzer LED will be steady on. Reinstating FA Alarm head or zone circuit or zone line fuse will bring the RCIE back to normal mode.

Repeat **Zone Fault Test** for rest of the zones.

5.1.4 Power Supply Test:

The RCIE constantly monitors the mains power source, standby battery/charger voltage and initiates a PSU fault if the voltage of the charger or standby batteries are abnormal.

Switch off the mains 230VAC input to FA40 RCIE,

- PSU Fault LED will flash



-
- General Fault LED will flash
 - Built-in RCIE buzzer will sound with Silence Buzzer LED flashing
 - General Fault – voltage free contact changes over

Press Silence Buzzer button at RCIE, the buzzer stops sounding and Silence Buzzer LED will be steady. Turn ON the mains 230VAC input and the RCIE will be back to normal mode.

Disconnect the back-up batteries termination to RCIE.

- PSU Fault LED will flash
- General Fault LED will flash
- Built-in RCIE buzzer will sound with Silence Buzzer LED flashing
- General Fault – voltage free contact changes over

Press Silence Buzzer button at FA40 RCIE, the buzzer stops sounding and Silence Buzzer LED will be steady. Reconnect the back-up batteries termination, and the RCIE will be back to normal mode.

5.1.5 ACF Inhibit Function Test:

FA40 RCIE has only one inhibit function. Access level 2 is required. This feature is essential for system testing and maintenance operations.

Turn 003 Key to Access Level 2 position. Press ACF Inhibit button at FA40 RCIE.

- General Disable LED will illuminate
- The ACF Inhibit LED will illuminate
- ACF Output- supervised 24Vdc will be isolated from any FA Alarms activation of FA40 RCIE Zones

Conduct Zone Alarm Test at any one of the zones and check to ensure the ACF Output is not activated.

Press again ACF Inhibit button at FA40 RCIE to normalise. The system will be back to normal.

5.1.6 Fire Mode Test:

Using a Smoke CAN, select a FA smoke alarm and spray an amount of “canned smoke” into the FA smoke alarm.

- The tested FA alarm head will sound.

At FA40 RCIE;

- General Fire LED will flash
- The respective Zone Fire LED will flash twice per second.
- The alarms type such as Smoke/ Heat/MCP or Sprinkler LED will flash based on the device activated/tested at the field
- All the FA Alarms connected to RCIE will sound (if Common Dip Switch setting for tested zone is selected at the main control board)
- Priority 1 (P1) Alarm - voltage free contact changes based on Alarm type (Heat/ MCP & Sprinkler)
- Priority 2 (P2) Alarm - voltage free contact changes over based on Alarm type (Smoke)
- Ancillary Control Function Output – supervised 24Vdc will be activated. The status of output will be indicated by ACF Active LED illuminated at the front of FA40 RCIE
- Built-in RCIE buzzer will sound with Silence Buzzer Indicator flash



Fire Products & Solutions

firealert

FA40 Operation Manual

FireAlert Smoke Alarm System Iss 0.5

Turn 003 key into access level 2, press Silence Buzzer to mute the RCIE buzzer.

- Silence buzzer indicator will be steady ON followed by Locate Alarm indicator flashes
- Press Locate Alarm button at RCIE
- All other FA Alarms will stop sounding, except the alarm(s) devices in the alarm condition, and Locate Alarm LED will be steady ON followed by Silence Alarm indicator flashes.

In case of real time operation, after the source alarm(s) is located, investigation on the premises is necessary. If there is a fire, immediately evacuate the premises and call the fire brigade.

If false alarms occur,

Press Silence Alarm button at RCIE;

- All FA Alarms stop sounding .
- The source alarm(s) device and RCIE will enter into 10 minutes silence period by showing steady ON Silence Alarm LED at RCIE.
- The general fire indicator, Alarm type indicator and the respective Zone fire indicator will remain flash through this silence period.















6 TROUBLE SHOOTING

6.1 FA Alarms

The FA alarms can communicate their status and history through various LED flashes and chirps/beeps.

6.1.1.1 FA014, FA016, FA024 Indicator Summary

Table 19: FA014, FA016 & FA024 Indicator & Sound patterns

Normal Mode					
Mode	Action	Green LED (power)	Yellow LED (fault)	Red LED (alarm)	Sound
Power up	Slide onto mounting plate	 x 1	 x 1	 x 1	-
Standby	-	 x 1	-	-	-
Testing	Press and hold test button	* 	-	-	
In alarm mode					
Detecting fire	-		-		
Activated via interconnect	-		-	-	
Pressing silence button on Alarm detecting fire	-		-		 X 10mins

* With the test button held the green LED will flicker/pulse every second

 = LED on solid  = LED Flashing



Fire Products & Solutions



FA40 Operation Manual

FireAlert Smoke Alarm System Iss 0.5

Table 20: Memory Mode indicator and Sound patterns























Status	Action	Red LED (alarm)	Sound
0-24h	-	 x2 every 48 sec	-
>24h +	Press and hold test button	 x 2 every 8 sec	
To erase the memory	Keep test button pressed for >20s		Sounds until test button is released

Table 21: Fault Mode and Memory Indicator.

What you hear / see				What it means	What to do
Green LED (power)	Yellow LED (fault)	Red LED (alarm)	Chirps		
 x 1 every 48 sec	-	-	-	Lost power from FA000	Reconnect Power, Check FA000 base for fault indication
-	 x 1 every 48 sec	-		No Power, running off battery backup	Reconnect power
	 x 1 every 48 sec	-		Low battery backup	Replace Alarm
	 x 2 every 48 sec	-	 x2	Sensor fault	Replace Alarm
	 x 3 every 48 sec	-	 x3	End of Life	Replace Alarm
	 x 4 every 48 sec	-	 x4	Max Dust compensation has been reached	Clean alarm §7.1
	Flashes as per fault type	-	-	Fault chirps have been silenced LED Flashing indicates fault type	If required chirping can be silenced again by pressing silence button
	-	 When pressing Test button	-	There has been an alarm in your absence	Check Alarm memory section



6.1.2 Low Battery Backup Fault

If the battery backup supply is depleted, the sounder will give one short chirp with one yellow LED fault indicator flash every 48 seconds. In this case, check that the green LED power indicator is on continuously. If it is off, or flashing every 48 seconds, the Alarm is not receiving 16Vdc power from the FA000 base and is being powered by the battery backup. The chirp every 48 seconds indicates that the battery is depleted. The battery is not replaceable. Check the FA000 base, fuses, circuit breakers and wiring to determine the cause of the interruption to the mains power. If in doubt, contact a qualified electrician. Once power is reinstated, the chirps should cease within 2 hours as the battery charges up. If the chirping persists for over 2 hours with the green light on, there may be some other problem with the Alarm. The Alarm must be returned for repair or replacement.

6.1.3 Sensor Fault

The Alarm regularly checks the photoelectric smoke sensor and/or thermistor heat sensor for correct operation. If the Alarm has found a fault with the sensor, it will give 2 short chirps with 2 yellow LED flashes every 48 seconds. In this case, the Alarm must be returned for repair or replacement.

6.1.4 End of Life

Once the Alarm passes its 10th year of installation, it will give 3 short chirps with 3 yellow LED flashes every 48 seconds to indicate it has reached its end of useful life. The entire Alarm must be replaced. Also check the replace by date on the label on the side of the Alarm. Disconnect the main power first and replace the Alarm. See, 'Removing the Alarm' section.

6.1.5 Max Dust compensation

The Alarm monitors the dust contamination build-up in the optical smoke chamber and then compensates for it, reducing the possibility of nuisance alarms. If, however, the Alarm gives 4 short chirps with 4 yellow LED flashes when the test button is pressed, it indicates that the Alarm has reached the maximum dust compensation. When this occurs, the Alarm will continue to operate as normal, but there is an increased risk of nuisance alarms caused by dust contamination. If contamination has occurred quickly (e.g. due to dust from carpets being replaced) and the Alarms are sounding, the dust compensation may take some hours to operate. In this situation, remove the Alarm from the ceiling, leave it disconnected for 5 minutes, then reinstall the unit (the air must be clean i.e., dust and smoke free). The dust compensation will now operate quickly, within 60 seconds.

Refer to the maintenance section §7.1.

6.1.6 Temporarily Silencing the Fault chirps

If the test / hush button is pressed on an Alarm that is giving fault chirps and yellow LED fault indicator flashes, the Alarm will be silenced (Fault Hush mode) for a period of 12 hours. However, the Alarm will sound / function as normal within that period should it detect Fire (except if the fault detected is a sensor fault). The yellow LED fault indicator will continue to flash as before to indicate the fault is still present. This is a useful feature should the fault occur at night as it keeps the disturbance at a time when people in the building are trying to sleep to a minimum. The fault chirps would return 12 hours later, which perhaps may be a more suitable time to address the fault issue with the Alarm. In case of low backup battery voltage and end of life fault chirps, this can be repeated as required. A sensor fault condition can only be hushed once.

7 MAINTENANCE

7.1 Cleaning alarms

Clean alarms regularly. In dusty areas it may be necessary to clean the Alarm more frequently.

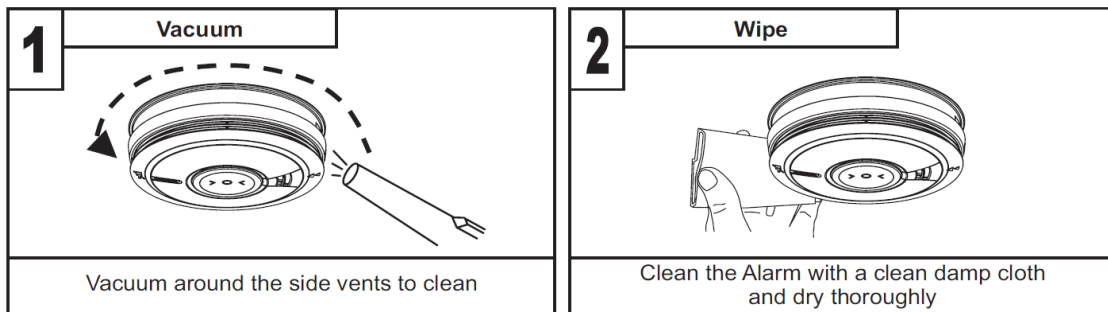

Use the narrow nozzle attachment of your vacuum cleaner to remove dust, insects and cobwebs from the sides and cover slots where the airflow enters. Clean the outside cover by occasionally wiping with a clean damp cloth, then dry thoroughly with a lint free cloth. Do not use any cleaning agents, bleaches, detergents or polishes, including those in aerosol cans.

7.2 Battery Maintenance

The batteries – 2 x 12V 9Ah SLA batteries are placed inside the FA40's plastic enclosure §3.1

The FA40 charges and monitors the batteries and continuously monitors their condition. A fault will be generated when the batteries are disconnected or outside the specified limits.

The ambient temperature affects the batteries capacity, self-discharge and life span. The temperature should preferably not be higher than normal room temperature (approximately 20-22°C) For highest safety, the batteries used in a fire alarm system should not be more than four years old.

Note: Risk of explosion if batteries are replaced by the incorrect type. Dispose of used batteries according to the manufacturers instructions and National regulations.

Skilled personnel are required to replace batteries.

8 BLOCK WIRING DIAGRAM

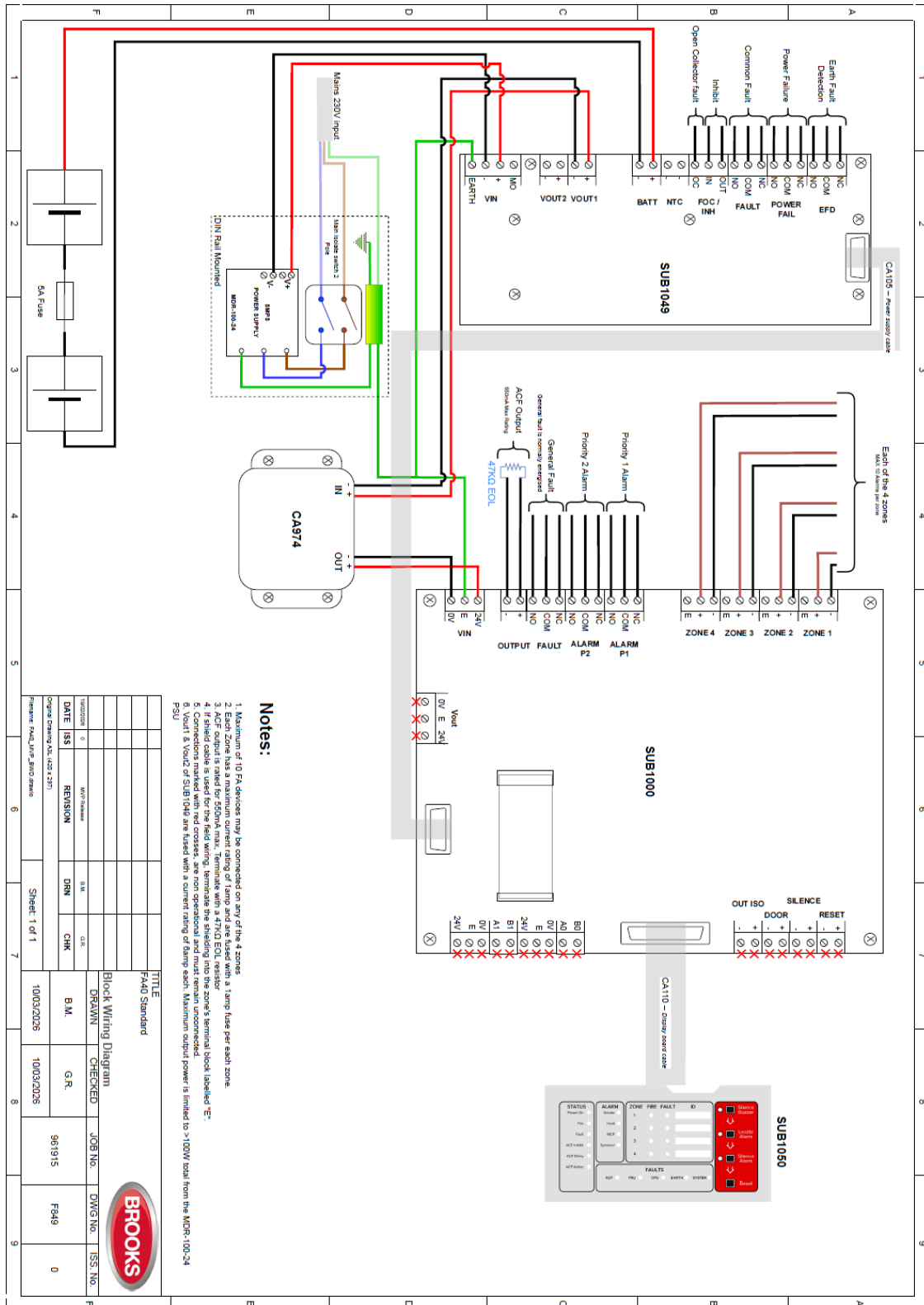

Figure 32: FA40 Standard Block Wiring Diagram



Fire Products & Solutions

firealert

FA40 Operation Manual

FireAlert Smoke Alarm System Iss 0.5

9 GUARANTEE

If the FA40 control panel, or any of its system components, have any defects due to faulty workmanship or material, it is to be returned to BROOKS freight paid. BROOKS will, at its sole discretion, repair or replace the item free of charge.

On returning a component or complete product, proof of purchase will be required. If returning the complete product, all accessories and documentation **MUST** be returned.

This guarantee does not cover damage caused to the product or its components because of incorrect installation, accident, negligence, misuse, unauthorised dismantling, contamination howsoever caused, careless handling, or where repairs have been made or attempted by others.

No other guarantees written or verbal are authorised to be made on behalf of BROOKS. All other conditions and warranties, whether expressed or implied are, to the extent permitted by law, hereby excluded.

As BROOKS has no control over the system's design, installation to the relevant Australian Standard or maintenance, the Company and its agents take no responsibility for any damage, consequential loss or injury caused to any equipment, property or persons resulting from the use of FireAlert FA40.

BROOKS guarantees FireAlert FA40 units for a period of 15 months from the date of purchasing the equipment or 12 months from the date of installation, whichever is greater.



Fire Products & Solutions

firealert

FA40 Operation Manual

FireAlert Smoke Alarm System Iss 0.5

NSW - Head Office

P.O. Box 7050 Silverwater NSW 1811

4 Pike Street Rydalmere NSW 2116

Ph: 02 9684 1466

Website: www.Brooks.com.au

VIC

Ph: 03 9879 5294

SA

Ph: 08 8347 0000

QLD

Ph: 07 3373 8222

WA

Ph: 08 6262 8095

Or National Australian Sales Number: 1300 783 473