



Deaf and Hard of Hearing Kit & Strobe

EIB170RFAU & EIB171RFAU

Installation Manual

Read and retain carefully for as long as the product is being used. It contains vital information on the installation and operation of this product. This manual should be regarded as part of the product.

If you are just installing the product, the manual **MUST** be given to the user.



Fire Products & Solutions

Contents

		Page
1.	Introduction	3
2.	Overview	4
3.	Technical Specifications	5
4.	Location	7
5.	Installation	7
6.	Testing the system	11
7.	Troubleshooting & Indicator Summary Tables	13
8.	Limitation of Deaf and Hard of Hearing Kit & Strobe	16
9.	Limitation of Radio communication	16
10.	Getting your device serviced	17
11.	Guarantee	17

Introduction

The Deaf and Hard of Hearing Kit (EIB170RFAU) & Strobe (EIB171RFAU) warn users, that a Fire or CO alarm installed in their home has been triggered. As it does not detect fire and/or CO, it can only operate if Brooks RF fire and/or CO Alarms are installed, powered up and connected to it.

The new design of the Deaf and Hard of Hearing Kit & Strobe has not only improved its visual appeal by making it much more compact but has also allowed us to integrate more features.

It can now indicate to the user whether a Fire or CO alarm has triggered the Controller. This allows the user to make the correct decision in relation to the steps to take. If the LED under the CO icon is illuminated, all doors and windows should be open while evacuating the premises. If the LED under the Fire icon is illuminated then the doors should be closed on the evacuation path while exiting the premises.

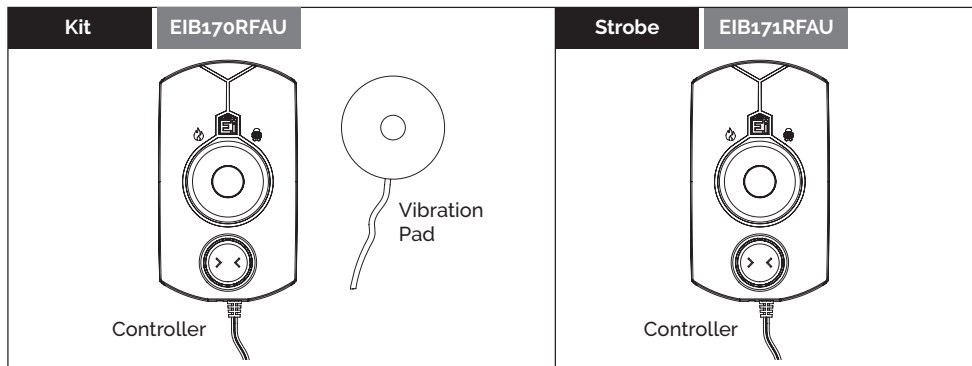

Overview

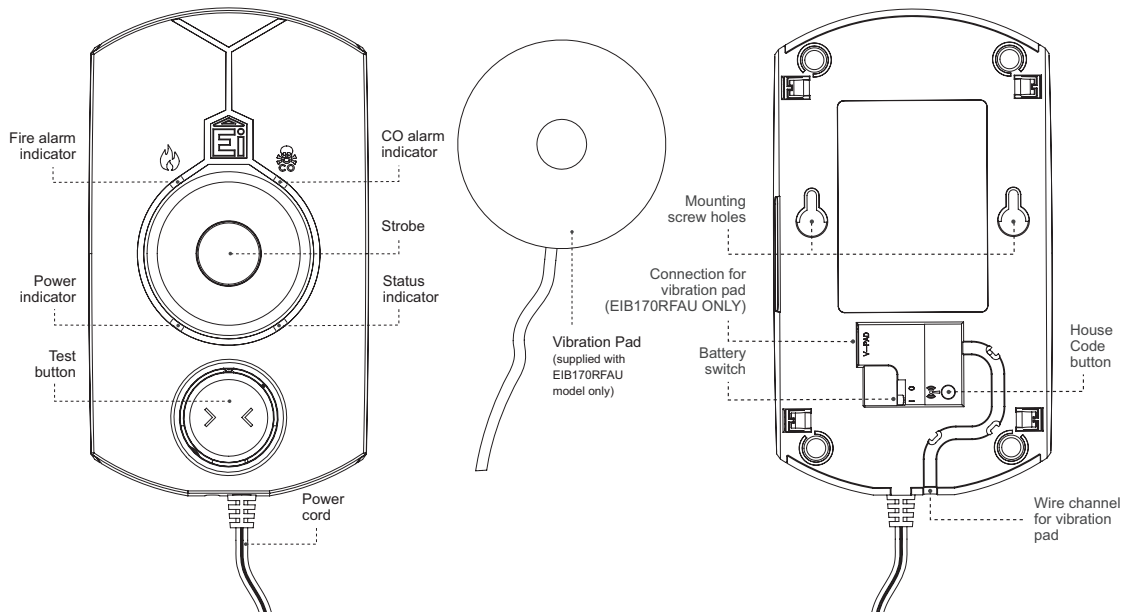

Technical Specification

Power supply	230 VAC, 50-60 Hz
Battery back-up	Rechargeable, 5V, 500 mAh (non replaceable)
Battery life (standby)	72 hours
Power consumption	3W (Max)
RF Frequency	926 MHz
RF Power	12dBm
RF Range	>100 metres in free air
RF Protocol	RadioLINK1 (RL1)
Max RF system size	12 RF devices
Receiver category	2
Test Button	Tests all visual indicators, vibration pad (EIB170RFAU only) and interconnection
Visual indicators	<p>Fire icon (RED flash) - Fire Alarm triggered</p> <p>CO icon (RED flash) - CO Alarm triggered</p> <p>Strobe flash - Alarm, Test button, pad not connected (EIB170RFAU only)</p> <p>Power indicator (Green LED)- connected to mains supply</p> <p>Status indicator - Test, RF, Fault</p>

Normal Operating and Storage Temperature Range	-10°C to 40°C
Normal Operating and Storage Humidity Range	15% - 95% Relative Humidity
Plastic Material	PC/ABS and HIPS, UL94 HB rated
IP Rating	IP20
Dimensions (mm)	Controller: 150mm x 86mm x 28mm Vibrating pad: 98mm x 34mm
Product Weight	604g (EIB170RFAU), 398g (EIB171RFAU)
Guarantee	5 years
Approvals	AS4268:2017 AS1603.17:2020 (EIB170RFAU only)

Location

The EIB170RFAU is best suited for bedrooms. It should be fixed such that the strobe light can be seen from the bed, and the vibration pad can be placed under the mattress or pillow to wake a person during either a fire or CO alarm.

The EIB171RFAU is suitable for any other rooms an individual would use while awake.

IMPORTANT: The Deaf and Hard of Hearing Kit or Strobe are not suitable for installation in bathrooms or shower rooms. they must not be exposed to dripping or splashing and no objects filled with liquids, such as vases, must be placed on or above the Controller.

IMPORTANT: Do not place the Deaf and Hard of Hearing Kit or Strobe in locations where the battery may be exposed to excessive heat such as sunshine, fire or the like.

Installation

1. If installing an EIB170RFAU, connect the vibration pad to the V-PAD socket (see *figure 2*). Ensure the vibration pad cable is inserted into the channel to facilitate wall installation (see *figure 3*).
2. Move the battery switch from 0 to I (see *figure 1*). The LEDs on the front of the Controller will light up in the following sequence: Fire (Red), CO (Red), and the status indicator will flash Red-Blue-Green.
3. Power up the Controller by plugging it into a mains socket. The power indicator will light up green and remain on. **Note:** the unit must not be wired directly to a mains junction box.
4. Interconnect the RF Alarms to the Controller.
 - 4.1 Place into house code mode the RF Alarms in accordance with the instructions given in their respective manual.

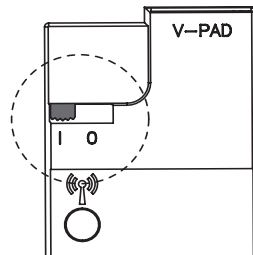

Figure 1 - Back of unit

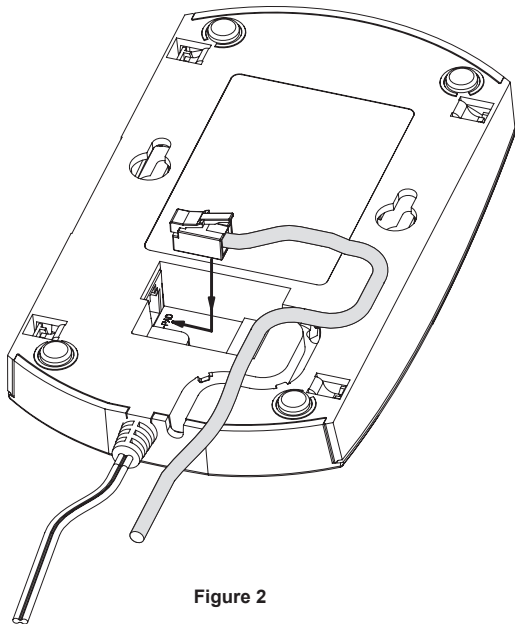

Figure 2

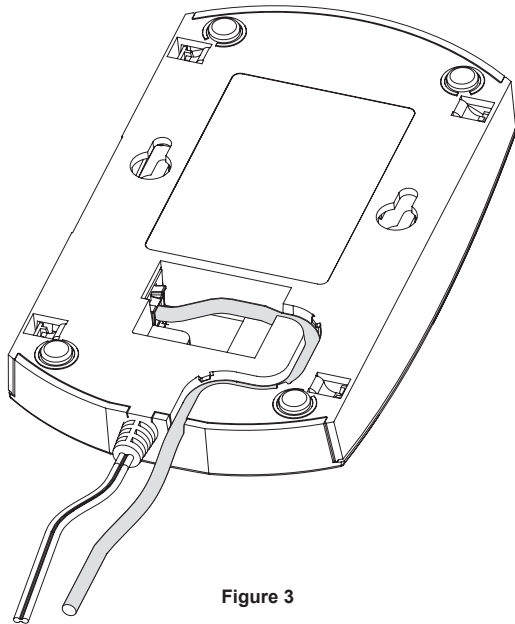

Figure 3

4.2 Press the house code button (see *overview diagram*) located at the back of the Controller until the status indicator illuminates blue at the front.

4.3 Immediately release the button. The status indicator LED will flash blue rapidly and then stop.

4.4 It will then continue to flash blue every 5 seconds.

4.5 To check that all devices have been successfully housecoded check that the amount of blue flashes on each RF device matches the number of devices in the system (i.e. 4 flashes if there are 4 RF devices in the system).

In a RadioLINK1 system, we recommend for ease of installation and RF communication, that a maximum of 12 RF devices be installed in any one RF coded system. Please contact us for further advice if additional RF devices are required.

4.6 To exit house code mode, press the house code button at the back of the Controller until the status indicator lights up blue and then release. It will now send a signal to all other RF devices in the system to exit house code mode. Alternatively, the RF devices will automatically exit the house code mode after 30 minutes.

Note: Always consult the individual RF device manual as some older RF devices may not respond to the exit house code mode signal.

4.7 Check the RF system by pressing the test button on any Alarm. After a few seconds all Alarms should sound and the Deaf and Hard of Hearing Kit will flash and vibrate in the following alternating sequence:

Strobe flash

Vibration of pad

Red LED flash of fire and CO icon with Status indicator LED green flash

5. In the case of an EIB170RFAU, place the vibration pad under the pillow or mattress. Check the positioning of the pad while lying on the bed by pressing the test button (this will also trigger the Alarms that are house coded to the Controller). It is important that the user can feel the vibration while in bed. Some mattresses may not transmit sufficient vibration, and in these cases, it should be fitted under the pillow.

6. The Controller can be left on a flat surface (i.e. table) or permanently fixed to the wall using the screws and plastic plugs enclosed (drilling template available on page 18). If fixed to a wall, the screws should be screwed into the wall leaving a gap of approximately 4 mm under the head. Fit the keyhole slots on the back of the Controller over the screw heads and slide the panel down vertically into position.

Factory Reset

Sometimes in order to resolve an RF communication issue it may be necessary to reset (factory reset) and house code the system again. To do so, press and hold the house code button on each device until the LED starts flashing, release immediately.

Remote House Coding

If it is necessary to extend an RF system, this can be done quite simply via the Remote House Coding feature.

Firstly, press the house code button at the back of the Controller. Keep the button pressed until you see all colours flashing (red, blue, green) and then release. The Controller will now send an RF message to all previously installed (compatible) devices to re-enter House Code mode.

Then, install and put the new RF device you wish to add to the system into House Code mode. Follow the House Coding steps as described in the new RF device manual.

Testing the system

Frequent testing of the system is a requirement to ensure its reliable operation.

Guidelines and best practices for testing are as follows:

1. After the system is installed.
2. Once monthly thereafter.
3. After prolonged absence from the dwelling (e.g. after holiday period).
4. After repair or servicing of any of the components.
5. After renovations to the house.

Inspecting and Testing procedure

1. Check that the green LED power indicator is on continuously on the Controller.
2. Check also that there are no faults i.e. NO yellow LED flashes (if this is the case please see indicator summary table).
3. Press and hold the test button on one of the Alarms. The RF indicator will illuminate on the Alarm. Continue to hold the test button until all the Alarms in the system are sounding, the strobe and LEDs flash and, for the EIB170RFAU, the vibration pad pulses. Release the test button when the test is completed.

Testing the rechargeable battery

The rechargeable battery can take up to 8 hours to charge when the unit is first powered up. It is then maintained in a fully charged state by a top-up charge.

In the event of a mains failure, the battery will power the Deaf and Hard of Hearing Kit & Strobe in standby for 72 hours and then be capable of at least 4 minutes of alarm. The status indicator LED will flash green every 60 seconds to indicate it is on battery power. If the status indicator LED flashes yellow while on battery power, it indicates that the battery is running low.

We recommend that the functioning of the rechargeable battery is checked at least yearly as follows:

- Ensure the Controller has been mains powered for at least the previous 8 hours for the battery to charge.
- Turn off the mains power to the unit by unplugging it. The green Power indicator LED will switch off.
- Press the test button on the Controller for 20 seconds and check that the strobe flashes brightly, the LEDs flash, the alarms all sound and, in the case of the EIB170RFAU, the pad vibrates. (Cover the strobe light to stop it dazzling you while performing the test).









If the strobe light or the vibrations of the pad are weak and the Controller has been powered by mains for more than 8 hours, the Deaf and Hard of Hearing Kit or Strobe will need to be replaced.





























Switching off Mains for long periods

If the premises are regularly being left without mains power for long periods, the battery should be disconnected, by moving the battery switch from I to 0, to prevent it from becoming fully depleted.

The Deaf and Hard of Hearing Kit & Strobe can significantly help to reduce the risk of fatalities due to fire or CO.

Troubleshooting & Indicator summary tables

Power Supply Indicator Table							
What you hear / see					Strobe	What it means	What to do
Power Indicator LED (Green)	Status indicator LED						
	Red	Blue	Green	Yellow			
—	—	—	—	—	—	AC mains OFF Battery switched OFF	Switch on battery Plug into mains
	—	—	—	—	—	AC mains ON Battery switched ON	—
	—	—	—	 every x1 3 sec	 every x1 3 sec	AC mains ON Battery switched OFF	Switch on battery
	—	—	—	 every x1 60 sec	—	AC mains ON Low battery backup	Replace Device if problem persists for more than 12 hours
—	—	—	 every x1 60 sec	—	—	AC mains OFF Battery ON	Reconnect AC mains power
—	—	—	—	 every x1 60 sec	—	AC mains OFF Low battery backup	Reconnect AC mains power

Indicator Summary Table										
Mode	Action	Power Indicator LED (Green)	 Red LED	 Red LED	Status indicator LED				Strobe ¹	Vibration pad
					Red	Blue	Green	Yellow		
Power up	Step 1: Switch on battery	—	 x 1	 x 1	 x 1	 x 1	 x 1	—	—	—
	Step 2: Plug into mains		—	—	—	—	—	—	—	—
Standby			—	—	—	—	—	—	—	—
Testing ²	By pressing the test button on an Alarm or on the device ³		 x 1 every 3 s	 x 1 every 3 s	—	—	 x 1 every 3 s	—	 x 1 every 3 s	 x 1 every 3 s
In Alarm ⁴	Activated by Fire Alarm		 x 1 every 3 s	—	—	—	—	—	 x 1 every 3 s	 x 1 every 3 s
	Activated by CO Alarm		—	 x 1 every 3 s	—	—	—	—	 x 1 every 3 s	 x 1 every 3 s
Fault	Low Battery		—	—	—	—	—	 x 1 every 60 s	—	—
	Pad fault ⁵		—	—	—	—	—	 x 2 every 60 s	—	—
	End of Life		—	—	—	—	—	 x 3 every 60 s	—	—

 = LED on solid  = LED flashing  = Pad vibrating







¹ In the case of the EiB170RFAU, if the strobe flashes for no reason, check the vibration pad is fully connected and the battery switch is set to on.



² The indicators flash/vibrate in an alternating sequence. The LEDs flash together, followed by the strobe and then the pad vibrates.

³ If a fault exist, pressing the test button on the Controller will flash the yellow LED as per fault condition. The relevant number of flashes will be 6 s apart.

⁴ Pressing the test button on the Controller during an alarm will stop the strobe from flashing to make it easier for the user to see which icon is lit (Fire or CO).

⁵ EiB170RFAU only

House Coding Indicator Table					
Mode	House Code Button	Status indicator LED			
		Red	Blue	Green	Yellow
Entering House code mode	Press and Release as soon as the LED lights up Blue	—		—	—
In House code mode ¹		—	 every 5 s	—	—
Exiting House code mode	Press and Release as soon as the LED lights up Blue	—		—	—
Factory Reset	Press until the LED starts flashing Blue. Then release.	—		—	—
Entering Remote House Coding	Press until the LED flashes Red - Blue - Green. Then release.				—

 = LED on solid  = LED flashing

¹ Initially the LED will flash once as the Controller is counting itself, then as it connects to other devices the number of flash will increase to show how many devices are connected to it.

Limitations of Deaf and Hard of Hearing Kit & Strobe

However, they may be ineffective in some situations. There are a number of reasons for this:

- The Deaf and Hard of Hearing Kit or Strobe will not work if they are not house coded to RF Fire and/or CO Alarms.
- A fire or CO event may not be detected by the Alarms if:
 - The Alarm batteries are depleted or not connected.
 - The Alarms are not installed as per the instructions given in their respective manuals.
- A person may not see the strobe flashing if something is obstructing it or left in front of it
- The Deaf and Hard of Hearing Kit or Strobe may not suffice to wake a person who has taken drugs or alcohol.

Limitations of Radio Communications

Brooks radio communication systems are very reliable and are tested to high standards. However, due to their low transmitting power and limited range (required by regulatory bodies) there are some limitations to be considered:

- (i) Receivers may be blocked by radio signals occurring on or near their operating frequencies, regardless of the House Coding.
- (ii) RF devices should be tested regularly, at least monthly. This is to determine whether there are sources of interference preventing communication, that the radio paths have not been disrupted by moving furniture or renovations, and if so, to give a warning of these and other faults.

Getting your device serviced

If, within the guarantee period, your device fails to work after you have carefully read all the instructions, checked that the device has been installed correctly, and is receiving AC power, contact us.

If you are advised to return your device, follow the instructions given and place the device in a padded box with the proof of purchase, your contact details and a note stating the nature of the fault.

Guarantee

Brooks guarantees this device for five years from the date of purchase against any defects that are due to faulty materials or workmanship. If this device should become defective within the guarantee period, we shall at our discretion repair or replace the faulty unit.

This guarantee only applies to normal conditions of use and service and does not include damage resulting from accident, neglect, misuse, unauthorised dismantling, or contamination howsoever caused. This guarantee excludes batteries which have degraded due to external factors outside of reasonable use and/or Brooks' control. This guarantee also excludes incidental and consequential damage.

This guarantee does not apply to any device that has been modified in any way by a third party or has been fitted with a third party element.

Do not interfere with this device or attempt to tamper with it. This will invalidate the guarantee but more importantly may expose the user to shock or fire hazards.

This guarantee is in addition to your statutory rights as a consumer.

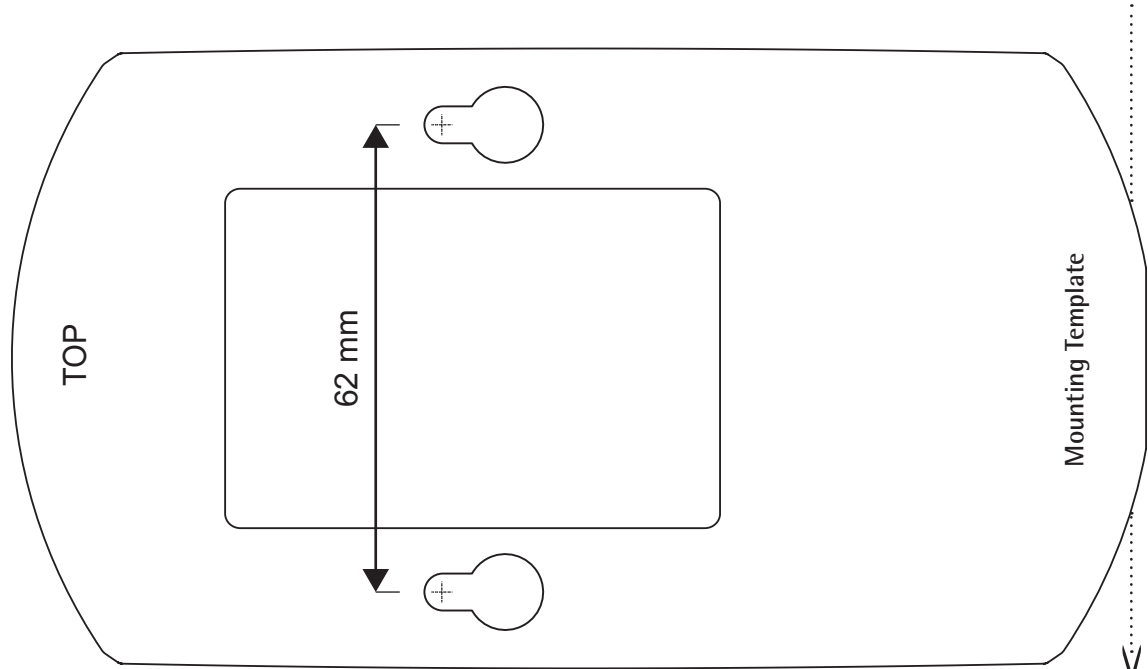



Fire Products & Solutions

Brooks Australia PTY Ltd.

NSW - Head Office
P.O. Box 7050 Silverwater NSW 1811
4 Pike Street Rydalmere NSW 2116
Ph: 02 9684 1466
Website: www.Brooks.com.au

VIC

9/71 Victoria Crescent, Abbotsford VIC 3067
Ph: 03 9879 5294

SA

P.O. Box 101 Woodville SA 5011
729A Port Road, Woodville, SA 5011
Ph: 08 8347 0000

QLD

P.O. Box 511 Archerfield QLD 4108
2/49 Boyland Ave Coopers Plains, QLD 4108
Ph: 07 3373 8222

WA

P.O. Box 2114, Midland DC W.A. 6936
6/91 Leach Highway, Kewdale WA 6105
Ph: 08 6262 8095

or National Australian Sales Number: 1300 78 FIRE (3473)
For the cost of local call