



Fire Products & Solutions

**Panasonic**

# Operation Manual

## FT1020G3

Rev 3.6

For Software V3.6

**firetracker**

## FT1020G3 FDCIE



This page has deliberately been left blank.

# Table of Contents

<b>1</b>	<b>Introduction.....</b>	<b>9</b>
1.1	Overview.....	9
1.2	Definitions / Explanations .....	9
<b>2</b>	<b>General Description .....</b>	<b>12</b>
2.1	The FT1020G3 FDCIE .....	12
2.2	Com Loop Units.....	13
2.3	Address and Mode .....	13
2.4	Software (S/W) Versions .....	13
2.4.1	EBLWin .....	13
2.4.2	TLON Manager .....	13
2.5	Applications .....	13
<b>3</b>	<b>Fire Detection Control &amp; Indicating Equipment (FDCIE) .....</b>	<b>14</b>
3.1	FT1020G3 Specifications .....	14
3.2	FT1020G3 Limitations .....	15
3.3	FT1020G3 FDCIE Layout.....	16
3.4	Front Display .....	17
3.4.1	LED Indicators and Push Buttons.....	18
3.4.1.1	Fire Brigade Panel Display and Control.....	18
3.4.1.2	FT1020G3 Display CP Indicators .....	19
3.4.2	The Display (LCD).....	20
3.4.2.1	Areas in the Display .....	20
3.4.2.2	Symbol Area .....	21
3.4.2.3	Information Area Priority Order .....	21
3.5	System Information in the LCD.....	22
3.5.1	User Definable System Information .....	22
<b>4</b>	<b>FT1020G3 Options.....</b>	<b>23</b>
4.1	I/O Matrix 4582 Circuit Functionality.....	23
4.2	Occupant Warning System (OWS).....	23
4.2.1	Standard OWS Display.....	23
4.3	Gaseous Extinguishing Control Module .....	24
4.4	Printer Option .....	25
<b>5</b>	<b>19” Rack Cabinet &amp; Brooks Loop Modules .....</b>	<b>27</b>
5.1	Cabinet Overview .....	27
5.2	Enclosure Components .....	28
5.3	New G3 Boards .....	28
5.3.1	Main Control Board 5012.....	28
5.3.2	Loop Board 5017.....	30
5.3.3	MMI Board 5015.....	30
5.3.4	Gateway – RS232 Interface .....	31
5.4	Addressable COM Loop Display Modules.....	32
5.4.1	Power monitor and loop connection module 1204 .....	33
5.4.2	Zone Control Module 1205.....	34
5.4.3	Fan / Damper Control Module 1206 / 1211.....	34
5.5	Generic FT1020G3 Display and Control Modules.....	37
5.5.1	Generic 8 Switches / 8 LED’s Display / Control Module 1207 .....	38
5.5.2	Generic 4 Switches / 8 LED’s Display / Control Module 1208.....	38
5.5.3	Generic 8 LED’s Display Module 1209.....	38
5.5.4	Pump status 6 LED’s Display Module 1210.....	38
5.6	I/O COM loop Field Modules .....	39
5.6.1	1200 Module – SUB997 .....	39

5.6.2	1202 Module – SUB994 .....	40
5.6.3	1203 Module – SUB991 .....	40
<b>6</b>	<b>User Data &amp; Access Levels .....</b>	<b>41</b>
6.1	User Data .....	41
6.1.1	User Name .....	41
6.1.2	Password .....	41
6.1.3	Password for Gateway Access only.....	42
6.2	Access Levels.....	42
6.2.1	How to Log On .....	42
6.2.2	Navigation / General Procedures.....	42
6.3	User Level .....	43
6.3.1	User Access Levels .....	43
6.3.2	User level 1 .....	43
6.3.3	User level 2A.....	43
6.3.4	User level 2B.....	44
6.3.5	User level 2C.....	44
6.3.6	User Level 3A.....	45
6.3.7	User level 3B.....	46
6.3.8	User level 4 .....	46
<b>7</b>	<b>Technical Number / Presentation Number.....</b>	<b>47</b>
7.1	Technical Number for COM Loop Units .....	47
7.2	Presentation Number.....	47
<b>8</b>	<b>Silence Alarm Devices .....</b>	<b>48</b>
8.1	SILENCE ALARM (inside switch).....	49
8.2	NZ FB “Silence Alarms” Bulgin key (outside switch).....	49
<b>9</b>	<b>Disable / Re-enable Alarm Devices.....</b>	<b>51</b>
<b>10</b>	<b>“SILENCE BUZZER” .....</b>	<b>52</b>
10.1	Silence buzzer by open door .....	52
10.2	Silence buzzer by the “FB Bulgin Key” .....	52
<b>11</b>	<b>Disable or Re-enable Output .....</b>	<b>53</b>
<b>12</b>	<b>Disable/Re-enable Control Outputs .....</b>	<b>54</b>
<b>13</b>	<b>“DISABLE” Button.....</b>	<b>55</b>
<b>14</b>	<b>Open Door .....</b>	<b>56</b>
14.1	Disable Routing Equipment with Door Switch .....	56
14.2	Silence Buzzer by Door Switch .....	56
<b>15</b>	<b>Alarm Types .....</b>	<b>57</b>
15.1	Pre-warning .....	57
15.2	Fire Alarm .....	58
15.2.1	Entering the Menus during Fire Alarm .....	60
15.2.2	Test Mode Alarm .....	60
15.3	Heavy Smoke Alarm / Heavy Heat Alarm .....	61
15.4	Alert Annunciation Alarm (AA alarm).....	61
15.5	Key Cabinet Alarm.....	62
15.6	Co-Incidence Alarm (2-Address / -Zone Dependence) .....	62
15.7	Delayed Alarm .....	63
15.7.1	Standard Alarm Delay Applications .....	63
15.7.2	Alarm Delay Facility (ADF) <sup>69</sup> .....	63
15.8	Local Alarm Acknowledgement (LAA) Facility Control.....	64
15.9	Quiet Alarm.....	64
15.10	Acknowledged and Isolated Alarm .....	65

15.10.1	Acknowledged Alarm.....	65
15.10.2	Isolated Alarm .....	65
15.11	Alarm Source .....	66
<b>16</b>	<b>Alarm Reset.....</b>	<b>67</b>
16.1	Pre-warning Reset.....	67
16.2	Fire Alarm Reset.....	67
16.2.1	All (Default) .....	67
16.2.2	Single .....	67
16.2.3	Single with Automatic Disablement.....	68
16.3	Test Mode Alarm .....	68
16.4	Acknowledged and Isolated Alarm (for only NZ) Reset.....	68
16.5	Heavy Smoke / Heat Alarm Reset.....	68
16.6	Alert Annunciation Alarm Reset .....	68
16.7	Co-incident Alarm Reset.....	68
16.8	Delayed Alarm Reset.....	68
16.9	Alarm Delay Facility (ADF) Reset.....	69
16.10	Local Alarm Acknowledgement (LAA) Reset .....	69
16.11	Quiet Alarm Reset .....	69
<b>17</b>	<b>Fault .....</b>	<b>70</b>
17.1	Fault Messages .....	71
17.2	Fault Acknowledge .....	87
<b>18</b>	<b>Commissioning an FT1020G3 .....</b>	<b>88</b>
18.1	General.....	88
18.2	Single Control Unit.....	88
18.3	Control Unit in an EBL Ring Network (5040).....	89
18.3.1	Network Board 5040 Installation .....	90
18.3.2	EBL Ring Network Programming.....	90
18.3.2.1	Set Control Unit Number .....	90
18.3.2.2	Set the Control Unit Order.....	90
18.4	Control Unit in a TLON Network.....	91
18.4.1	Control Unit in a TLON Network .....	91
18.5	Upgrade Number of Alarm Points .....	92
<b>19</b>	<b>Software Installation and SSD Download .....</b>	<b>93</b>
19.1	EBLWin Software Requirements.....	93
19.2	EBLWin Installation Procedures in a PC First Time .....	93
19.2.1	.NET Framework .....	93
19.2.2	USB Drivers Installation.....	94
19.2.3	HASP Driver Installation (for 5094 key) .....	97
19.2.4	EBLWin software Installation .....	97
19.2.5	Installation of EBL Firmware Manager.....	99
19.2.6	Download SSD .....	101
19.2.6.1	Version Control for SSD Download.....	101
19.2.6.2	SSD Download procedures: .....	101
19.2.7	SSD Download Messages of a Single Control Unit.....	103
19.2.8	SSD Download to Control Units in a TLON Network.....	103
19.2.9	User Definable Text messages Download .....	103
<b>20</b>	<b>Download Software (System Firmware).....</b>	<b>104</b>
20.1	Download System Firmware to Single FDCIE.....	104
20.2	Download Software in a TLON Network.....	106
20.3	Download Software in an EBL Ring Network .....	107
20.4	Software Versions .....	107
<b>21</b>	<b>Restart .....</b>	<b>108</b>

21.1	Safe Shut Down.....	108
21.2	Restart Table .....	108
21.2.1	Explanation of Restart Codes .....	109
21.3	During Restart .....	109
21.3.1	Memory fault .....	110
<b>22</b>	<b>Perform Monthly Test (H1).....</b>	<b>111</b>
<b>23</b>	<b>Disable or Re-enable (H2).....</b>	<b>113</b>
23.1	Zone or Zone Address (H2/B1) .....	114
23.2	Output (H2/B2) .....	116
23.3	Output Type (H2/B3) .....	118
23.4	Alarm Devices (H2/B4).....	120
23.5	Routing Equipment / ASE (H2/B5) .....	122
23.6	Alert Annunciation (H2/B6).....	124
<b>24</b>	<b>Set Calendar and Clock (H3) .....</b>	<b>126</b>
24.1	Daylight Saving Time.....	126
<b>25</b>	<b>Present System Status (H4).....</b>	<b>127</b>
25.1	Disablement (H4/U1) .....	127
25.2	Disablement by Time Channel (H4/U2).....	128
25.3	Open Doors (H4/U3).....	129
25.4	Sensor Values (H4/U4).....	130
25.5	Sensors Activating SERVICE Signal (H4/U5) .....	132
25.6	Technical Warning (H4/U6) .....	133
25.7	Event Log (H4/U7).....	134
25.8	Information (H4/U8).....	135
<b>26</b>	<b>Service (H5).....</b>	<b>136</b>
26.1	Calibration of Supervised Outputs (H5/A1) .....	137
26.2	Sensitive Fault Detection Mode (H5/A2).....	138
26.3	Service Mode for COM-Loop (H5/A3) .....	139
26.4	Display Current Consumption in Unit (H5/A4).....	140
26.4.1	Power Supply (Control Unit) .....	140
26.4.2	Power Supply Auxiliary Outputs .....	140
26.4.3	Battery.....	140
26.5	Display Current Consumption on COM-loop (H5/A5).....	142
26.6	Display Statistics for Communication (H5/A6).....	143
26.7	Activate Address Setting Mode for DU (H5/A7) .....	144
26.8	Setup wireless detectors (H5/A8) .....	145
26.9	SSD Information (H5/A9).....	147
<b>27</b>	<b>FAULT Acknowledge (H6) .....</b>	<b>148</b>
<b>28</b>	<b>Perform Zone Test (Test mode) (H7) .....</b>	<b>149</b>
<b>29</b>	<b>Maintenance (H8).....</b>	<b>151</b>
29.1	Disconnect / Reconnect Loop / Zone Line Input (H8/S1).....	151
29.2	Acknowledge SERVICE Signal (H8/S2).....	153
29.3	Clear Weekly Average (H8/S3) .....	155
29.4	Test of Alarm Devices (H8/S4).....	156
29.5	Safe Shut Down of Control Unit (H8/S5) .....	157
29.6	Activate Address in Alarm Mode (H8/S6).....	159
29.7	Synchronise the Control Units (H8/S7) .....	161
29.8	Activate / Reset outputs (H8/S8) .....	163
<b>30</b>	<b>Interlocking Outputs and Inputs (H9) .....</b>	<b>165</b>
30.1	Activated Interlocking Outputs / Inputs (H9/C1) .....	165
30.2	Activate / Deactivate Interlocking Output (H9/C2).....	166
30.3	Disable / re-enable interlocking output (H9/C3) .....	168
<b>31</b>	<b>Change Password (H10) .....</b>	<b>169</b>

<b>32</b>	<b>FDCIE Maintenance .....</b>	<b>170</b>
32.1	Replacing a TLON Connection Board and/or the Main Board .....	170
32.2	Battery Maintenance .....	171
<b>33</b>	<b>How to Avoid Nuisance Fire Alarms .....</b>	<b>172</b>
<b>34</b>	<b>Block Wiring Diagram .....</b>	<b>174</b>
<b>35</b>	<b>Guarantee .....</b>	<b>179</b>
<b>36</b>	<b>Revision history.....</b>	<b>180</b>
36.1	Operation Manual Revisions Table .....	180
36.2	Software Revision V3.6.0 Enhancement Features .....	180

## Table of Figures

Figure 1	Connection diagram of FT1020G3.....	12
Figure 2	FT1020G3 with Optional OWS and Control/Display Modules .....	16
Figure 3	FT1020G3 front display .....	17
Figure 4	Occupant Warning System Display .....	24
Figure 5	Gas Extinguishing Display Layout .....	25
Figure 6	Serial Interface Module.....	26
Figure 7	FT1020G3 Mounted in 22U Large 19" Rack Enclosure .....	27
Figure 8	Main Board 5012 .....	29
Figure 9	Loop board 5017 .....	30
Figure 10	MMI Board 5015.....	31
Figure 11	3U Ancillary Modules Face Plate.....	32
Figure 12	1204 Power Monitor Module.....	33
Figure 13	1205 Zone Control Module .....	34
Figure 14	1206 / 1211 Fan / Damper Control Module.....	35
Figure 15	Display and control modules.....	38
Figure 16	Single I/O 1200 connection and SUB997 PCB .....	39
Figure 17	4/4 1204 I/O SUB994 .....	40
Figure 18	8/8 1203 I/O SUB991 .....	40
Figure 19	Final Display Device Manager .....	96
Figure 20	Installing HASPUserSetup in compatibility mode.....	97
Figure 21	Auxiliary 24V outputs limitation.....	140
Figure 22	19" Rack 22U FT1020G3 General Arrangement with 6U battery box .....	175
Figure 23	19" Rack 13U FT1020G3 General Arrangement with 6U battery box .....	176
Figure 24	FT1020G3 Standard Block Wiring Diagram.....	177
Figure 25	FT1020G3 New 5012 PCB Layout .....	178

## List of Tables

Table 1 Definitions and Explanations	9
Table 2 Control unit specifications	14
Table 3 Control Unit limitations	15
Table 4 LED indicators and push buttons on Fire Brigade Panel (FBP)	18
Table 5 LED indicators on Control Panel (CP)	19
Table 6 Push buttons / keypad on Control Panel (CP)	20
Table 7 Symbol indications	21
Table 8 Priority Order	21
Table 9 I/O Matrix addressing	23
Table 10 OWS Controls and Indications	24
Table 11 Gas Front Status LED Indication and flash Pattern	25
Table 12 Module specifications	33
Table 13 Fan indicators and controls	36
Table 14 Damper indicators and controls	37
Table 15 Levels of access	43
Table 16 Access Levels and user names	43
Table 17 Latest Software Versions for FT1020G3	107
Table 18 Data affected by restart	108
Table 19 Algorithms and abbreviations in NORMAL mode	131
Table 20 Algorithms in ADVANCED mode	131

# 1 Introduction

## 1.1 Overview

FT1020G3 Operation Manual is a document intended to be used by the end user and the fire brigade personnel as well as service / commissioning engineers.

The block wiring diagrams of the standard FT1020G3 in 19" rack configurations and general arrangements are shown in Chapter 34 page 174.

Due to continual development and improvement, different S/W versions are to be found. This document is valid for software (firmware) **version 3.6.x** . On the date of printing this manual  $x = 0$ .

The system software version is the firmware downloaded in to the Control Unit via PC Windows based software e.g. EBL512G3 V3.6.x . The latest system software is factory downloaded in FT1020G3 before delivery is EBL512G3 V3.6.x . However, new software may be upgraded to a newer revision on site.

The software version is dependent on the country where the control panel to be installed, that is due to the variations in the standard in each country. Two separate software versions are available, Australian (AU) and New Zealand (NZ).

The PC software is Windows based software **EBLWin** which has to be installed in your PC, and must have the first two digits of the version number identical to the system software (firmware) version number i.e. version 3.6.x . The **EBLWin** is used to download the firmware and the Site-Specific Data (SSD) into the FDCIE.

Only the first two digits **must be** identical in the software and the **EBLWin** version number i.e. 3.6.x ( $x =$  minor modifications).

## 1.2 Definitions / Explanations

Definitions / explanations and abbreviations are used frequently in this document and are shown in Table 1 below.

Table 1 Definitions and Explanations

Device or function	Description
Alarm points	Units, which can generate a fire alarm in FT1020G3, i.e. analogue detectors (sensors), MCP's, conventional detectors, etc.
Smoke detector	Analogue or conventional photoelectric smoke detector
Sensor	Sensor = Analogue detector
Analogue detector	Contains an A/D-converter. The FT1020G3 picks up the digital values ("sensor values") for each detector individually. All evaluations and "decisions" are then taken by alarm algorithms in the FDCIE. The latest detector generation (440x) can be used in "Advanced mode", i.e. the alarm algorithms are in the detector instead. Analogue detectors are addressable, an address setting tool 4414E is used to write the address and select the required mode of the detectors on a COM loop. An analogue detector has to be plugged in an Analogue Sensor Base (ASB).
Analogue Sensor Base (ASB)	An analogue detector is plugged in an ASB, which is connected to a COM loop (see below).

Conventional detector	A detector with only two statuses, i.e. normal or fire alarm. The detector has a "closing contact" and a series alarm resistor. Normally plugged in a conventional detector base CDB (see below), which is connected to a conventional zone line input. Some types are water proof types and cannot be plugged in the standard base, it is connected directly to a zone line. An end-of-line device has to be connected in the last unit on the conventional zone line.
Conventional Detector Base (CDB)	A conventional detector is plugged in a CDB, connected to a conventional zone line input.
Addressable Units	A unit with a built-in address device. Each unit is individually identified, handled and indicated in the FDCIE. The unit can be an I/O unit with a zone line input, to which one or more conventional "alarm points" can be connected (It can also be one of Brooks addressable modules 1200,1202 & 1203).
Conventional zone line input	Input intended for one or more conventional alarm points. End-of-line device in the last alarm point on the zone must be fitted.
Output unit	Addressable unit with programmable control outputs. Connected to a COM loop (see below).
Output / Control output	Defined or programmable function. Relay output or voltage output (supervised or non-supervised), in the FDCIE or an output unit connected to a COM loop.
Short circuit isolator (ISO)	Addressable unit for automatic disconnection of a COM loop segment (see below) in case of short circuit on the loop. As per AS1670.1, one isolator is required every zone on the COM loop.
Remote Display Unit (RDU)	Addressable unit (RS485 line) for fire alarm presentation (including user definable alarm text), alert annunciation, etc., end of line resistor must be set via a jumper link on the last unit.
COM loop	Loop = twisted pair cable, to which all the addressable units can be connected. Starts in the FDCIE and returns back to the FDCIE.
Control Unit / C.U. / FDCIE	Control Unit = Fire Detection Control and Indicating Equipment (FDCIE) = Unit to which the alarm points are connected (via e.g. a COM loop). Indicates on the front fire alarm, fault conditions, etc.
Fire Brigade Panel (FBP)	The fire brigade panel is an integral part of FT1020G3 intended for fire alarm, fault and disablement presentation, etc. The FBP comprises the top part of the front display. Intended for fire alarm presentation and for the fire brigade personnel.
Control panel (CP)	A part of the FT1020G3 front display, intended for fire brigade or service personnel, building officer, etc., to "communicate" with the Control Unit / system. It comprises the bottom part of the front display.
System / Installation	One or several control units connected via a network (co-operating control units).
EBL Ring Networking systems with network board 5040	Network system to utilise 5040 with fibre optic or twisted pair as a redundant network. To connect a control unit to a network, two network board 5040 has to be plugged in each control unit. The EBL Ring Network programming (configuration) is made in EBLWin
Network 5090 / TLON® / LonWorks® / Echelon / Node / TLON Conn. board / Channel / Backbone net / Router / Repeater	Brief explanations to the words/expressions to be found in connection with a "TLON Network". See also separate TLON Technical description. TLON® = TeleLarm Local Operating Network = a LonWorks®-based network for communication between several control units/nodes. The protocol is called LonTalk and the transmission works with doubly- terminated bus topology (Echelon FTT-10). To connect a control unit to a network, a TLON connection board has to be plugged in each control unit. FT1020G3 also supports a redundant TLON Network. In this case two TLON connection boards have to be plugged in each control unit. A network can be one channel (FTT-10) or several channels,

	connected via routers. In TLON Network, subnet = channel. Routers are used for safety reasons in a single TLON Network (up to six control units per channel). Routers can also be used to increase the distance (cable length) between the end nodes in a channel. Router or Repeater is the same type of unit (different configuration). All network programming (configuration) is configured using the PC program "TLON Manager". See also separate TLON Manager Technical Manual.
Nuisance alarms	False or unwanted alarms
LED	LED (Light Emitting Diode) = Yellow, green or red optical indicator ("lamp").
External Indicator / RIL	A unit with a red LED connected to a base (ASB / CDB) or a detector with an output for a remote indicator RIL. Lit when the built-in LED in the detector / base is lit.
Display / LCD	LCD (Liquid Crystal Display) = Display (in the FDCIE or Display unit) for presentation of fire alarms, fault messages, etc. In FT1020G3, the display is a graphical monochrome LCD (320 x 240 dots) with backlight.
Door open (Door / Key switch)	A door switch is provided in FT1020G3, which activates when the FDCIE door is open. Door open feature can be used to disable fault, strobes or OWS. An open door is indicated in the LCD (i.e. an "open door" icon).
Site Specific Data (SSD)	The SSD is unique for each system. All alarm points, presentation numbers, user definable alarm texts, programmable outputs, etc. are created in the PC program EBLWin and downloaded in FT1020G3 unit(s) with EBLWin.
Software (S/W) / Firmware / System program	The software (S/W) – also called Firmware and System program – makes the control unit (the microprocessor) work. It is factory downloaded but another / new version can be downloaded in FT1020G3 on site using EBLWin.
EBLWin	PC program used to create and download the SSD in FT1020G3 unit(s). Also used to download another / new software version and to upgrade the maximum number of alarm points in FT1020G3. Can be used during commissioning / maintenance of FT1020G3 system (auto address, check loop, acknowledge faults, etc.)
Gateway	The Gateway is used to get FT1020G3 information as well as remote control via a PC (browser) and an intranet / internet. Gateway is configured via the PC tool EBLWin.
EBL Firmware Manager	PC program, used to download another / new software version.
Multi master system	Each control unit in a network has access to all information.

**Note:** The network configuration must be performed prior creating the Site Specific Data (SSD).

## 2 General Description

### 2.1 The FT1020G3 FDCIE

**FT1020G3** is a microprocessor controlled intelligent fire alarm system, intended for analogue addressable detectors, as well as conventional detectors and manual call points. Four loops are available to connect addressable units e.g. On each COM loop it is possible to connect up to four SUB-loops.

Programmable control outputs and output units are available.

Up to 1012 addresses can be connected to each FT1020G3. Figure 1 below presents an overview of the FT1020G3 system.

Programmable control outputs and output units are available.

**FT1020G3** is available in several types e.g. large FT1020G3L and small FT1020G3S, cabinets, versions and configurations. It can be used as a standalone FDCIE or connected to a network, i.e. in a "system", with up to 30 Control Units. Each Control Unit has access to all information.

**FT1020G3** is designed and assessed to the Australian Standard AS7240.2, AS7240.4 and NZS4512:2010. The Fire Brigade Panel controls are incorporated as part of the front fascia and conforms to AS4438.3.

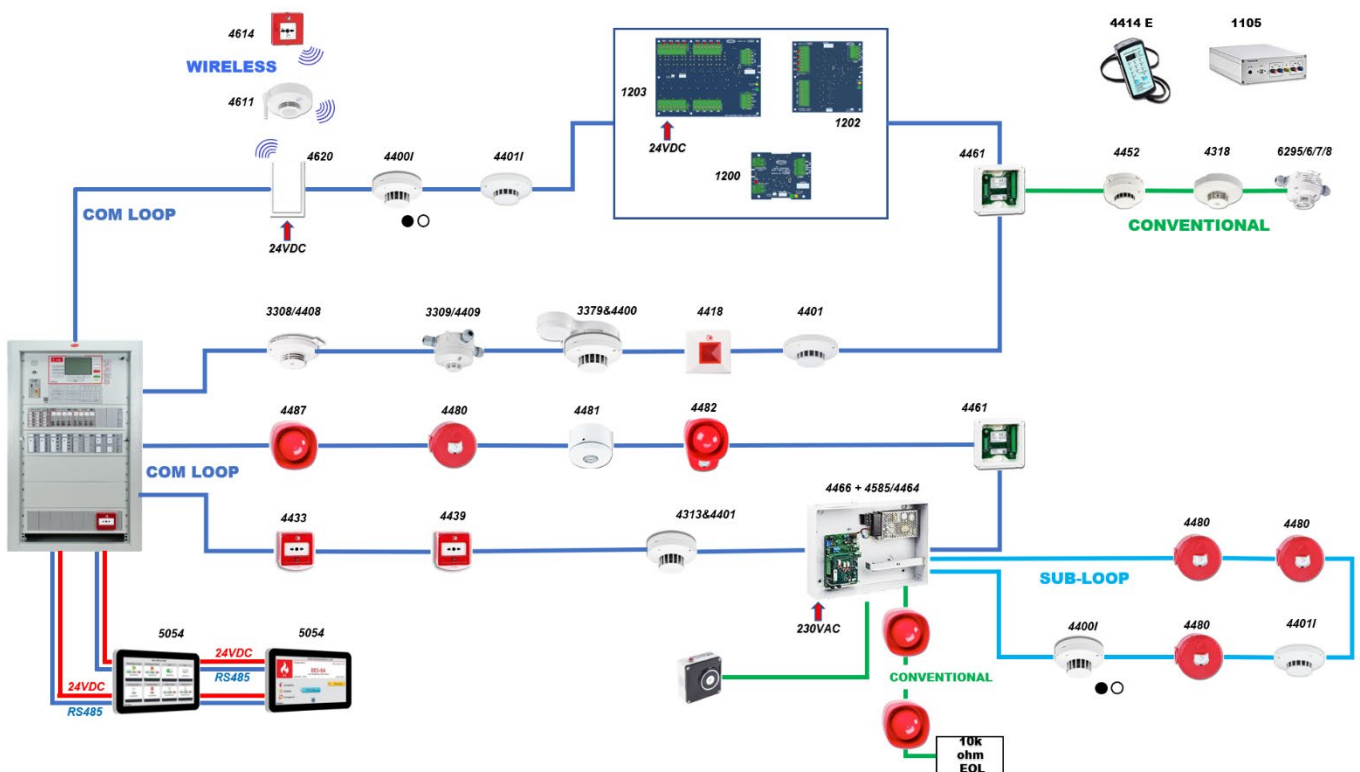

Figure 1 Connection diagram of FT1020G3

**Note:** Some units are currently in the approval process e.g. 4466, 4585, 4464, etc.

#### Technical Number

The technical number, NNNNNN, is used when programming all units connected to the COM loops. Technical number is also used to identify which unit has generated a fault. See detail in section 7.1, page 47 .

#### Presentation Number

Each fire alarm point / input / zone has a presentation number, NNN-NN. The presentation number is shown in the FDCIE display to identify the point / zone activating fire alarm. See section 7.2, page 47 .

## **2.2 Com Loop Units**

Addressable COM loop units are connected directly to a COM loop.

## **2.3 Address and Mode**

The addressable units must have both address and mode set. This is done in different ways for different units, for example address setting tool 4414E, DIP switches, jumpers, or via the FDCIE display. For more information, please refer to the Technical Description of each unit respectively.

## **2.4 Software (S/W) Versions**

Due to continual development and improvement, different S/W versions may be found. When installing a new Control Unit in a system with "older S/W" Control Units, you must upgrade the S/W in the old Control Units with the current S/W or downgrade the new Control Unit software by downloading the same older S/W version in the new Control Unit. The same S/W version is required in all Control Units in a TLON Network or EBL Ring Network.

### **2.4.1 EBLWin**

The PC program EBLWin is used for programming and commissioning of one or more Control Units.

EBLWin Key 5094 is a USB dongle that has to be plugged in the PC in order to log on to the FDCIE.

### **2.4.2 TLON Manager**

TLON Manager is an installation and maintenance tool used for the TLON Network programming and setup, it is Windows based PC software. Used to configure TLON network card 5090.

## **2.5 Applications**

The FT1020G3 system is intended for small, medium and large installations. The intelligent Control Units offer the system designer and end user a technically sophisticated range of facilities and functions.

Programming with the PC programs EBLWin and TLON Manager and commissioning of the Control Unit / system is an easy process. Start with one Control Unit and then, when required, add more units. The EBL Ring Network or TLON network allow the installer to install the Control Units in one building or in different buildings.

## 3 Fire Detection Control & Indicating Equipment (FDCIE)

### 3.1 FT1020G3 Specifications

Table 2 Control unit specifications

Item	Specifications
Mains Voltage	230V <sub>AC</sub> (195-253), 2 A
System Voltage	24V <sub>DC</sub> @ 6.5A
Current Consumption	Quiescent / alarm current is calculated by EBLWin and is dependent on other equipment fitted in FT1020G3, type and number of expansion boards, connected external equipment, etc.
Ambient Temperature (°C)	Operating 0 to + 40, Storage -40 to +70
Ambient humidity (%RH)	Maximum 90, non-condensing
Cabinet Size (mm)	Small 19" cabinet 13U, 700H x 600W x 250D
	Large 19" cabinet 22U, 1050H x 600W x 250D
	Battery box 19" cabinet 6U, 350H x 700W x 250D
Enclosure Material	1.5 Zinc annealed steel
Enclosure Colour	Oyster, ripple finish
Approvals	AS7240.2:2018, AS7240.4:2018, AS4428.3:2020 and NZS4512:2010
Standard Inputs / Outputs <sup>1</sup>	Four COM loops (0-3), each loop can connect up to 253 devices
	Four programmable non-supervised / supervised inputs (N/O or N/C) I0-I3 <sup>2</sup>
	Four Programmable Supervised Voltage Outputs, 0.5 Amp each
	Two Programmable Relay Outputs, contact rating 2 Amp
	Two non-programmable relay outputs for ASE (fire & fault)
	Six x 24V <sub>DC</sub> outputs for Gateway, ASE, Remote Display Units, external applications 0.5 – 3.15 Amp.
Expansion Boards	Max. 6 of 4580 or 4581 or a combination <sup>3</sup> of both.
I/O Matrix 4582 board (I/O matrix display modules)	Max. 24, 6 per COM loop if no Expansion Boards on Loop 0 <sup>4</sup> fitted. Up to 6 modules can be used as zone or generic + 18 Fan Control Modules (4 fans per module) <sup>5</sup>

**Note:** I/o matrix 4582 is now integrated in the new zone control 1205, fan control 1206 and damper control 1211 modules, same limitations apply. Refer to Chapter 5.4, page 32.

<sup>1</sup> Refer to G3 block wiring diagrams in chapter 34 Figure 24 page177

<sup>2</sup> First input I0 cannot be used in NZ convention, only 3 programmable inputs are available.

<sup>3</sup> Expansion boards are internally connected to COM loop 0, ensure total number of Expansion Boards and modules with built-in I/O matrix connected to COM loop 0 does not exceed 6.

<sup>4</sup> Reduce the number of modules containing I/O matrix 4582 circuits connected to COM loop 0 by one for every Expansion Board used.

<sup>5</sup> If no Expansion Boards fitted, up to 24 fan/damper control modules can be used i.e. 96 individual fan/damper

### 3.2 FT1020G3 Limitations

The limitations in V3.6 are controlled by EBLWin, however the following table lists some of the limitations.

Table 3 Control Unit limitations

Item	Loop	FDCIE	Network System
General fire alarm via programmable input <sup>6</sup>		100	30 x 100
External fault via programmable input		100	30 x 100
Programmable inputs		512	30 x 512
Programmable outputs (= control expressions)		512	30 x 512
Technical warnings		200	30 x 200
Interlocking Combinations		400	4000
Presentation numbers / alarm points that can be presented in the display(s) in case of fire alarm	255	512	512
Presentation numbers that can be programmed		512	30 x 512
Zones that can be programmed	255	512	999
Zone Group			64
Control Group			100
Faults			300
Disabled Zones			512
Disabled Alarm Points (zone/address) + Disabled COM loops			200 <sup>7</sup>
Disabled Outputs			200 <sup>8</sup>
Disabled Interlocking Outputs			200
Sensors activating SERVICE signal			200
LAA zones (Max. 5 detectors per AAF zone.)		100	30 x 100
Total number of Expansion Boards 4580 and 4581 <sup>9</sup>		6	30 x 6
Number of I/O Matrix Boards 4582 <sup>10</sup>		24	30 x 24
Total number of 4582 for Zone Control & Generic applications		6	30 x 6
Maximum number of remote display units 5054		30	30 x 30
Maximum number of 19" rack fan/damper modules with built-in 4582 (4 fan/damper for each module)		24	30 x 24
Maximum number of 19" rack zone modules with built-in 4582 (15 zone)		6	30 x 6

**Note:** The addresses 254 and 255 in each loop are reserved for auto addressing purposes and cannot be used. If these addresses are used there will be a fault in the "Validity check".

<sup>6</sup> Configuring an input for general fire alarm may cause delay in the alarm response in the FDCIE

<sup>7</sup> Zone/address disabled via time channel not included.

<sup>8</sup> Control outputs disabled via menu H2/B3 and Alarm devices disabled via menu H2/B4 are not included.

<sup>9</sup> Expansion boards 4580 and 4581 are physical connected to COM loop 0

<sup>10</sup> Reduce no. of I/O matrix modules by one for every Expansion Board used (4580 or 4581), applicable to 19" rack modules for zone control and fan / damper control.

### 3.3 FT1020G3 FDCIE Layout

The FT1020G3 is available in many configurations depending on the number of options fitted in the FDCIE. The 19" rack cabinet 22U style is shown in Figure 2 below.

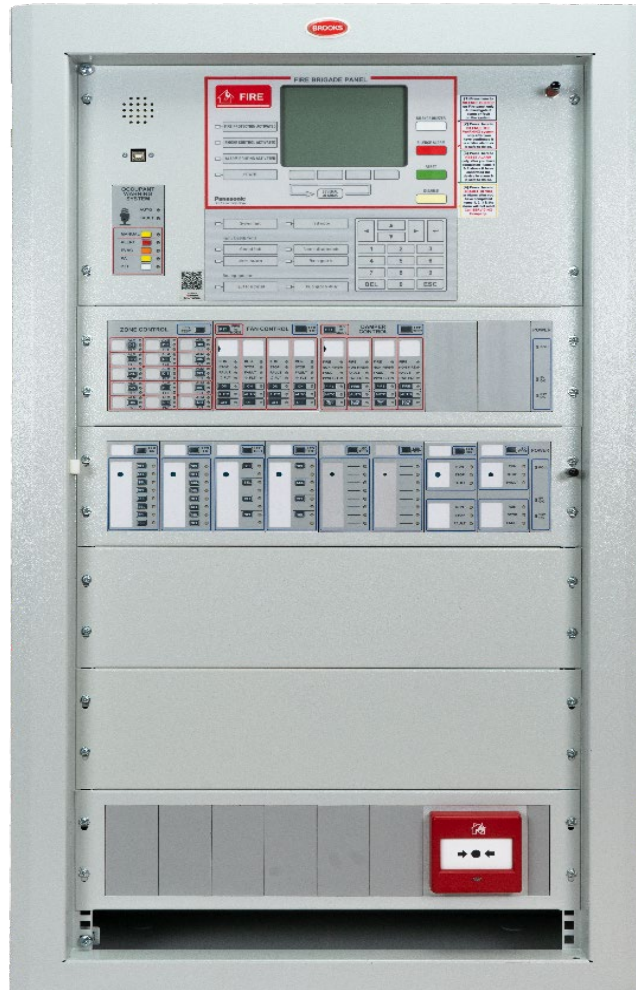

Figure 2 FT1020G3 with Optional OWS and Control/Display Modules

The cabinet is fitted with different options e.g. Occupant Warning System (OWS), Zone Control Module, Fan/damper control module, 1200 series ancillary modules, MCP, etc. Refer to the general arrangement in Figure 22 page 175.

The appearance and functions of FT1020G3 may vary depending on the number of optional modules fitted.

**Note:** Custom's hardware is required to add the options.

The 19" rack FT1020G3 22U Control and Indicating Equipment (FDCIE) shown in Figure 2 is housed in an oyster coloured powder coated metal cabinet. The cabinet has an inner metal door and acrylic outer door. The outer door is fitted with 003 keys to provide access level 1 and is made of tinted high impact acrylic which allows for easy viewing of all indicators and controls. The appearance of the FT1020G3 might vary based on the number of options fitted, cabinet size, additional battery enclosure, etc.

Access to the inner door is gained by opening the outer door which then provides access to the inner door fixing screws. Opening the inner door allows access to the Control Unit hardware for the purpose of maintenance or service.

Each FT1020G3 has the following basic configuration:

- Metal cabinet powder coated oyster with smoky acrylic door as shown above. Different sizes available.
- MMI board 5015, see Figure 10 page 31.

- Main board 5012, see Figure 8 page 29.
  - 4 x COM loops (0-3) to which the loop units are connected, refer to Figure 24 page 177.
  - 4 x programmable supervised voltage outputs (S0-S3), refer to Figure 24 page 177.
  - 2 x programmable relay outputs (R0-R1), refer to Figure 24 page 177.
  - 4 x programmable supervised / non-supervised inputs (I0-I3), refer to Figure 24 page 177.
  - 6 x 24 V DC outputs (power supply outputs for display units, Gateway, ASE, etc. Current limitation of each output must be considered.
  - 2 x non-programmable relay outputs for ASE, Fire brigade tx (alarm) and Fault tx (fault). Fault relay is normally energised, see Figure 24 page 177..
  - Screw terminals for two TLON network boards **type 5090 only**. For EBL Ring network boards type 5040, separate RJ connectors are provided.
  - Screw terminals for redundant RS485 and 24 VDC outputs for Display Units 5054, can be utilised as two separate splits, refer to Figure 24 page 177.
  - Connector for expansion boards (4580 & 4581), refer to Figure 24 page 177.
  - Connectors for Gateway, refer to Figure 24 page 177.
  - Screw terminals for power supply and batteries, refer to Figure 24 page 177..
- Power supply, refer to Figure 24 page 177.
  - Switch mode power supply, 230 VAC / 24 VDC (LS150-24).
  - Space and connection cables for two Sealed Lead-Acid backup batteries. Optional 6U height battery box is available for additional batteries.
  - Battery temperature sensor.
- Space for up to six expansion boards 458x.

**Note:** Some drawings shown in Chapter 34 page 174, others are shown in a separate drawing document

### 3.4 Front Display



Figure 3 FT1020G3 front display

The Fire Brigade Panel (section framed by red boarder) is integrated in the main FT1020G3 front display. FBP is normally used by fire services personnel to investigate which alarm point / zone(s) have activated a fire alarm and take the required operational control of the system. Fire brigade personnel can control active alarms via the buttons and keys P1-P4 and P9 within the FBP. P5 – P8 buttons are used to navigate the menu. In the graphical display, the information displayed in the upper part is dependent on how many alarm points / zones have generated fire alarm. In the middle part, the fire alarms will be shown, i.e. one alarm point or one zone together with a user definable alarm text (if programmed) plus some other information.

The Control Panel CP is used to "communicate" with the system, i.e. for commissioning, monthly tests, maintenance, etc. Access code for different access levels is required. To get access to the system (a menu tree with main and sub menus) and for operational control of the system, up to ten User names can be used for three different User level types. A Password (six digits) for each user name is required to logon to the panel and Gateway.

### 3.4.1 LED Indicators and Push Buttons

LED's and push buttons are contained on the front panel display and are described in the tables below. See also Figure 3 above, for the LEDs and push buttons.

#### 3.4.1.1 Fire Brigade Panel Display and Control

Table 4 LED indicators and push buttons on Fire Brigade Panel (FBP)

No	Label	Colour	Indicating / Action
L1	Fire	5xRed	Fire alarms. See chapter "Alarm types", page 57.
L2	Fire Protection Activated	Red	Outputs for extinguishing (suppression) equipment activated or any input type Extinguishing is activated.
L3	Smoke Control Activated	Yellow	Output(s) for smoke control ventilation equipment (AS1668) activated (fan / damper). Or a programmable input type "Ventilation" is activated.
L4	ASE Activated (Alarm Routing)	Red	Output "Fire alarm" for Fire Brigade TX and/or corresponding programmable output(s) of type "FireBrigadeTx" is/are activated (or a programmable input type "Activated routing equipment" is activated).
L5	Power	Green	Steady: FDCIE is powered via the primary power supply and/or the battery. Flashing: FDCIE start up or loop disconnected at start up.
L6	Several Alarms	2xRed	Multiple units / zones have activated fire alarm. Use push button P9 "Several Alarms" to scroll amongst the alarm points or soft key P6 "Next zone" to scroll amongst the zones.
P1	Silence Buzzer	White	Used to silence the buzzer in the FDCIE when it is sounding
P2	Silence Alarm	Red	Used to silence alarm devices e.g. OWS / sounders in the building when they sound. Silenced alarm devices is indicated to the right in the display's soft key area (a symbol near this button), see Table 6 page 20.
P3	Reset	Green	Used to reset fire alarms, only after all fire alarms have been silenced, see "Fire alarm reset", page 67. <b>Note:</b> P3 has to be pressed for > 0.5 sec.
P4	Disable	Yellow	Used to disable active alarm(s), all outputs of the device or zone in alarm will be disabled and reset after fire alarm devices have been silenced.
P5 to P8	Soft keys	Grey	Operation/function is shown above each soft key in the display area. The function of a soft key may vary depending on the FDCIE condition. If no text is shown above the key in the display, means the key has no function <sup>11</sup>
P9	Several Alarms	Grey	Used when LEDs "Several Alarms" (L6) are lit, scroll through the queued alarm points or zone-addresses. For more details, see chapter "Fire alarm" page 58. <b>Note:</b> To scroll/browse through the queued <u>zones</u> , use the soft key "Next zone" (P5).

<sup>11</sup> The soft key "P8" has the function Alert Annunciation Acknowledge, if a COM loop unit is configured for alert annunciation.

### 3.4.1.2 FT1020G3 Display CP Indicators

Table 5 LED indicators on Control Panel (CP)

No.	LED Indicator	Colour	Indicating
L7	System fault	Yellow	FT1020G3 is not running due to one of the following: <ul style="list-style-type: none"> <li>• S/W fault</li> <li>• CPU fault</li> <li>• Memory fault</li> <li>• No contact between main board and MMI board</li> <li>• FDCIE restart (fault code ≠ 00 / 03 / 25 / 50 / 53)</li> </ul>
L8	Test mode	Yellow	One or more zones are in "test mode", see page 111 & 149.
Fault / Disablements			
L9	General fault	Yellow	Fault(s) in the system, i.e. not acknowledged fault(s) and / or not corrected fault(s) <sup>12</sup> . See also page 148.
L10	General disablements	Yellow	Disablement(s) in the system.
L11	Alarm devices	Yellow	<b>Steady:</b> Output(s) type "Alarm devices" are <u>disabled</u> . <b>Flashing:</b> Output(s) type "Alarm devices" have generated <u>fault(s)</u> . This is also valid when the FDCIE has no "contact" with a unit with such an output, e.g. 3379, 4487, etc.
L12	Fire brigade TX	Yellow	<b>Steady:</b> Output(s) for "ASE" <u>disabled</u> <sup>13</sup> via menu (H2/B5). <b>Flashing:</b> ASE (routing equipment) power supply output <sup>14</sup> or one or more supervised outputs (of type "Routing equipment" have generated <u>fault(s)</u> . This is also valid when the FDCIE has lost "contact" with a unit with such an output, e.g. 4461.
ASE (routing equipment)			
L13	Fault TX activated	Yellow	One or more of faults not serviced <sup>15</sup> . Output "Fault condition" for fault TX (routing equipment) is activated. Test of routing equipment in progress (see menu H1). Sensitive fault detection mode is on (see menu H5/A2).
L14	Fire brigade TX delay	Yellow	The <b>Alert Annunciation</b> function is enabled.

**Note:** Acknowledged alarm and isolated alarm are used only in the NZ convention.





<sup>12</sup> Serviced fault will clear if the fault is set to non-latching in the system properties

<sup>13</sup> Serviced fault will clear if the fault is set to non-latching in the system properties

<sup>14</sup> Main board 5012 Terminal Block "J3:3-4", fuse F8 (T500mA 250 V – 5x20mm Ceramic).

<sup>15</sup> See also chapter "Fault acknowledge"

Table 6 Push buttons / keypad on Control Panel (CP)

Key/push button		Operation/function
	↵ (Enter)	Used to accept / select a menu or input of data. Also used to acknowledge fault signal and service signal.
	◀ ▶ ▲ ▼	Left / right keys used to move the cursor in a menu. Up / down keys used to scroll between the menus.
	0 - 9	Numeric key pad for the digits 0-9. Can be used to input data and in the menu system to jump to a menu with a corresponding number (e.g. 5 for a jump to menu H5).
	DEL	Used to clear /delete all visible entry fields.
	ESC	Used to stop input of data or to step upwards "one step up" in the menu system (e.g. from a sub menu to the main menu).

### 3.4.2 The Display (LCD)

#### 3.4.2.1 Areas in the Display

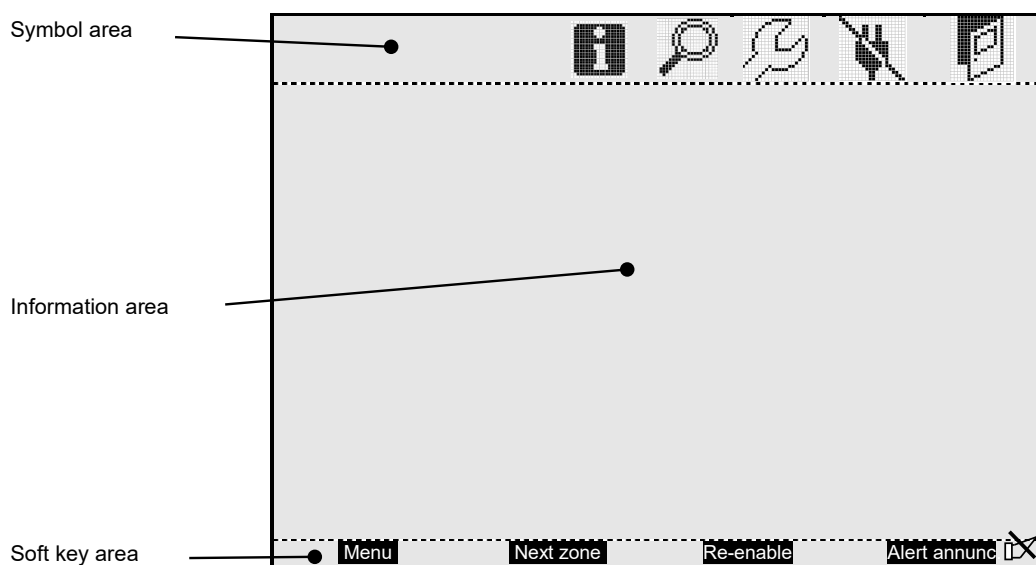

The display is split to three areas:







- **Symbol area:** Some events are indicated with symbols, see Table 7 below.
- **Information area:** General area for all other information and the menu system.
- **Soft key area:** The functions of the soft keys are shown in the bottom section of the display. The soft keys will vary depending on the system condition and convention. If no text is shown, the soft key has no function. The last soft key is used to acknowledge an "Alert Annunciation" alarm (if programmed). In the New Zealand convention, it is used to "Acknowledge Alarm".

Silenced Alarms are indicated by the symbol  to the right in this area.

### 3.4.2.2 Symbol Area

The symbol area is located at the top of the display, see chapter 3.4.2.1 above.

Table 7 Symbol indications

Symbol area	
Symbol	Indicating
	The door is open in any FDCIE. See "Open Door" page 56. See also menu H4/U3.
	Loss of mains in any FDCIE or external power supply unit in the system, i.e. the power is supplied via battery backup.
	Service signal. The week average sensor value has exceeded the service level or a detector is outdated for one or more analogue smoke sensors in the system. See also page 138 and menu H4/U5. When the symbol is flashing, the system will be in service mode i.e.: <ul style="list-style-type: none"> <li>• A COM loop is disconnected</li> <li>• A COM loop is in service mode</li> <li>• A Zone line input is disconnected</li> <li>• Check loop, Autogenerate loop or Auto-addressing function, etc. is in progress</li> </ul>
	The FDCIE is set in "Sensitive fault detection mode" via menu H5/A2, see page 138.
	One or more "Technical warnings" are generated in the system. See also menu H4/U6.
	Indicates that alarm devices are silenced

Note that the symbol area may be suppressed see Table 8 below.

### 3.4.2.3 Information Area Priority Order

When the FT1020G3 is in normal operation (quiescent state), i.e. no fire alarms, no faults, no disablements, no service signals, no zones in test mode, no activated interlocking inputs / outputs, and/or Alert Annunciation function not enabled, only the LED "POWER" should be lit and some **system information** is shown in the Control Unit display. However, the system information has the lowest priority and more important information suppresses less important. In some cases, also valid for the symbol area. The priority order is shown in Table 8 below.

Table 8 Priority Order

Priority	Event	Symbol area is visible
1	Fire alarms: <ul style="list-style-type: none"> <li>• Fire alarm</li> <li>• Heavy smoke / heat alarm</li> <li>• Alert Annunciation (AA) alarm</li> </ul>	No
2	Quiet alarm	No
3	Co-incident alarm	No
4	Delayed alarm	No
5	Pre-warning	No
6	Test mode alarm	No
7	LAA (AAF) alarm	Yes
8	<i>For only NZ convention:</i> Routing equipment left isolated	Yes
9	Fault (not acknowledged)	Yes
10	Disablement	Yes
11	Zones in "Test mode"	Yes
12	Interlocking input / output active	Yes
13	System information	Yes

### 3.5 System Information in the LCD

FT1020G3, Control Unit number, date and time are displayed. An example of the information area shown below:



dd-mm-yyyy = (Date) Day-month-Year

Control Unit; XX = 00-29

hh:mm = (Time) hour:minute

#### 3.5.1 User Definable System Information

User definable system / installation information (created and downloaded via EBLWin) can be displayed in the middle of the display as shown in the example below. Two rows are available, 38 characters in total. This information is shown in all Control Units in the system.

One example:



## 4 FT1020G3 Options

### 4.1 I/O Matrix 4582 Circuit Functionality

The I/O matrix 4582 circuit is utilised as an interface between the FDCIE (COM loop) and various types of applications e.g. AS1668 fan / damper control, Zone Disable and indication, etc.

The I/O matrix circuit is now incorporated in multiple user interface boards for different applications in a 19" format cabinets. The I/O matrix user interface in 19" format is connected to a COM loop and 24Vdc supply via 1204 module as explained in chapter 5 "19" Rack Cabinet & Brooks Loop Modules" page 27.

**Note:** The I/O matrix board 4582 and its application boards have been discontinued and replaced by the 19" rack modules with built-in I/O matrix circuit for zone and fan / damper modules.

Up to 24 of the I/O matrix circuits can be used in FT1020G3 if no Expansion Boards type 4580 or 4581 are used. The limitation of the I/O matrix configuration as follows:

- Up to six I/O matrix circuit can be programmed in FT1020G3 FDCIE as type "Zone control" (1205).
- Up to 24 I/O matrix circuit can be programmed as type "Fan control" (1206) or "Damper control" (1211) if no other I/O matrix circuits are used as zone control i.e. up to 96 fans / dampers can be controlled and displayed in FT1020G3.
- A combination of any of the two previous options can be used if the maximum number of each application is maintained.

The address setting of the I/O matrix applications in a COM loop is set to address 0-5 via jumper links JP1-JP3 shown in Table 9 below.

Table 9 I/O Matrix addressing

Board Address	JP1	JP2	JP3
0			
1	Fitted		
2		Fitted	
3	Fitted	Fitted	
4			Fitted
5	Fitted		Fitted

### 4.2 Occupant Warning System (OWS)

#### 4.2.1 Standard OWS Display

The standard Brooks OWS display and control layout is shown in Figure 4 below. For more details, refer to the standalone OWS manual MA380.

Brooks Occupant Warning System is a single zone evacuation system designed to provide warning to the occupant to evacuate the building in the event of fire or emergency. The single speaker circuit can split to multiple speaker circuits activated from the single output. Up to 48 supervised speaker circuits can be utilised via 12 x 4 zone splitter cards SUB999 Number of splitter cards SUB999 is dependent on the available space in the standard cabinet, larger enclosures can be used to allow for additional splitters.

The OWS comprises an amplifier, control / indication front, optional zone splitter cards and speakers / strobes distributed within the building to provide audible and visual warning to the occupant as well as PA notifications. In addition to the T3, the OWS provides in its standard configuration alert and evacuation messages as well as electret microphone for PA purposes. Dynamic hand-held microphone can also be used on request.



Figure 4 Occupant Warning System Display

The Brooks OWS provides high quality audio output utilising high efficiency class D amplifier, sizes available: 60W, 120W and 225W<sup>16</sup>. The front display push buttons / indicators and its function are explained in Table 10 below.

**Note:** fault will be generated if the manual mode is kept active for more than 5 minutes

Table 10 OWS Controls and Indications

LED indicators & Buttons		Indicating
Manual	LED – Yellow	Illuminates to indicate “Manual” activation
	Button	Enables manual activation of Alert, Evac or PA.
Alert	LED – Red	Indicates that alert tone/message is active
	Button	Manual trigger of the alert tone/message
Evac	LED - Red	Indicates that evacuation tone/message is active
	Button	Manual trigger of the evacuation tone/message
PA	LED - Yellow	Indicates that PA is enabled
	Button	Enables PA mode
Press to Talk PPT	LED - Yellow	Indicates PA is broadcasting
	Button	Press and hold to broadcast via the electret mic
Fault	Yellow	Indicates common fault in OWS i.e. speaker fault, trigger fault, input fault, etc.

### 4.3 Gaseous Extinguishing Control Module

The gaseous extinguishing control module is available to use as an option in FT1020G3. The gas module provides outputs to drive the following:

- A combination of Brooks Warning Signs
- Brooks Local Control Station (LCS)
- Voice / Tone Electronic Sounder
- Dual Strobe Module

The gas control module combined with other Brooks system components has been designed to provide monitoring and control functions of a complete gaseous extinguishing system that conforms to the requirements of the relevant clauses 7.1 to 7.6 of the Australian Standard AS4214-2002 (including amendment 1). For more details, refer to FT2GAS Operation / Technical Manual MA400.

<sup>16</sup> OWS comprises of 60W, 120W and 225W driven by their own separate power supply.

The gaseous extinguishing front display is shown in Figure 5 below. All LED indicators on the front display are covered by a polycarbonate decal clearly labelled with their functions. When the system is in normal condition, all LED indicators will be extinguished.

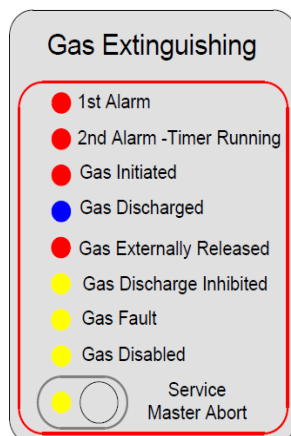

Figure 5 Gas Extinguishing Display Layout

The gaseous extinguishing system status LEDs and flash patterns are described in Table 11 below. The default state of the LED indicators is OFF, if it is not defined in the table.

Table 11 Gas Front Status LED Indication and flash Pattern

Type	LED Name	Module Conditions	LED Pattern
Alarm	1st Alarm - Red	One zone or zone address in alarm	Fast Flash
	2nd Alarm – Red, Timer Running	Both zones or zone addresses in alarm	
	Gas Initiated - Red	Gas release output activated	
	Gas Externally Released - Red	External gas release control activated	
	Gas Discharged - Blue	Gas discharged sensor input activated	
Fault	Gas Fault - Yellow	Fault in any of the supervised inputs or outputs	Steady ON
Disable	Gas Discharge Inhibited - Yellow	Gas discharge inhibited via LCS isolate switch	Steady ON
	Gas Discharge Disabled - Yellow	Gas discharge disabled by the service master abort switch or the gas lock-off valve controls	
	Service Switch Active - Yellow	Illuminates when the master abort switch is activated	
	Service, Master Abort	Gas service master abort switch	

## 4.4 Printer Option

As of firmware version V2.4.9 onwards, the printer option on the FT1020G3 can be converted into a serial data interface in the Australian Convention. This feature provides the panel with the capability to output serial bit stream data via a selection of either RS232 or RS485 interface.

The serial interface module is designed to send out the alarm messages from the FT1020G3 FDCIE via a fully isolated serial connection. Connection is made to the FDCIE via the printer terminal on the 5015 MMI board using the supplied cable loom CA332. The output is required to be enabled via EBLWin by enabling the printer option.

The serial interface PCB is shown in Figure 6 below. For detailed information, please refer to the Technical Datasheet TDS069 for detailed information on the serial interface module.

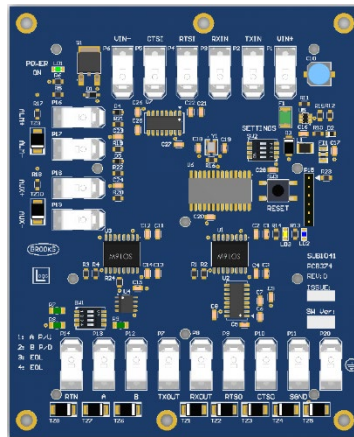

Figure 6 Serial Interface Module

## 5 19" Rack Cabinet & Brooks Loop Modules

### 5.1 Cabinet Overview

The Brooks 19" rack cabinets are designed to suit Brooks modular display / control modules. The enclosures are available in the following cabinet size:

- Large 22U enclosure 1050mm High x 600mm Wide x 250mm Deep, Figure 22
- Small 13U enclosure 700mm High x 600mm Wide x 250mm Deep, Figure 23
- Battery 6U enclosure 350mm High x 600mm Wide x 250mm Deep, Figure 22 page 175 and Figure 23 page 176

Any combination of the three cabinet sizes can be manufactured. The battery 6U enclosure is normally fitted below either of 22U or 13U enclosure to allow for larger batteries should the need arise. Cabinets support optional side by side mounting for large systems.

When the battery enclosure is to be used with the 22U enclosure, the whole cabinet should be mounted on a plinth on the floor such that the LCD display would be at the eye level.

These addressable FT1020G3 19" rack panels are fully customisable to site requirements and its racks are modularised in design.

A possible layout for FT1020G3 Mounted in 22U Cabinet is shown in Figure 7. Small enclosure can also be used for FT1020G3).

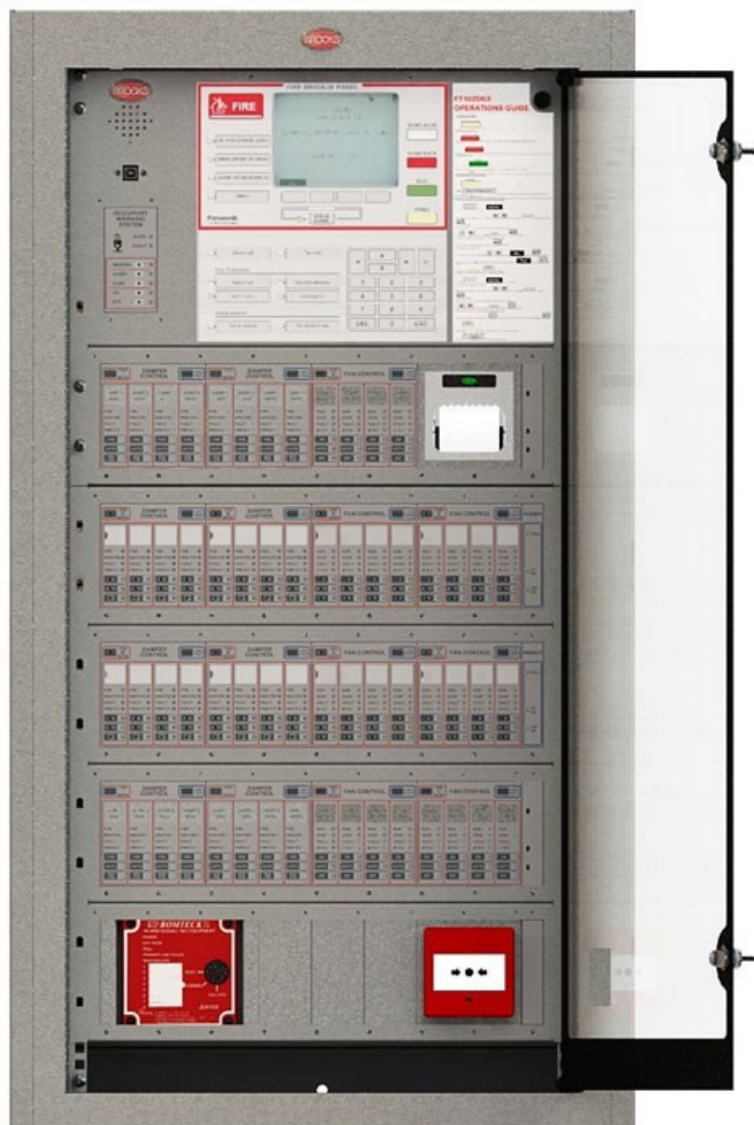

Figure 7 FT1020G3 Mounted in 22U Large 19" Rack Enclosure

## 5.2 Enclosure Components

Each 22U, 13U or 6U cabinet can be fitted with standard and optional face plates, equipment plates, ancillary racks, etc. The available plates as follows:

- FT1020G3 6U face plate with OWS display module integrated
- 19 Inch Rack equipment plate for FT1020G3
- Standard ancillary 3U rack for mounting display modules
- Standard 3U blank rack to fill up the unused racks
- Blank cover 125 x 50 mm (12B1) to cover unused display module
- Blank cover 125 x 20 mm (12B2) to cover unused power monitor module
- Blank cover 125 x 100 mm (12B3) to cover unused zone/fan display module
- Standard plates for mounting MCP, 20HP Plate (125 x 100 mm)
- ASE options: Romteck ASE mounting bracket, Tyco ASE mounting bracket and Code Red ASE mounting bracket
- Battery shelf 6U for 19 Inch rack cabinet

Choosing either 22U or 13U enclosure is dependent on the number of options added to the FT1020G3 system. All ancillary racks are 3U which can be fitted with every possible optional module. 1U is left opened below both 19" rack cabinets for easy access and storage of site documentation. A 003 key is required to open the outer acrylic door to access the controls on the panel.

## 5.3 New G3 Boards

### 5.3.1 Main Control Board 5012

The 5010 and 5011 are redesigned with more modern components resulting in better performance. New main control board 5012 replaces 5010 and new display driver board 5015 replaces 5011. The 5012 / 5015 are backwards compatible for software not less than V2.10.x.

The following are some of the features:

- Improved design with over voltage protection, improved drivers and more accurate current limitation.
- Main board 5012 is backward compatible with 5010 and can be connected to an existing TLON network with software  $\geq$  V2.10.4.
- MMI board 5015 is backward compatible with 5011.
- Higher stabilised supply voltage results in approximately 55% longer loop length.
- Improved monitoring due to accurate measuring the loop resistance which increases the reliability.
- Redundant communication (only software  $\geq$  V3.6.x) and power supply for display units. Other connection and wiring are identical. The redundant RS485 bus can be utilised as two separate buses if redundancy is not required.
- Large number of fuses have been replaced with PTC resettable electronic fuses e.g. supervised voltage output. Remaining fuses uses M205 ceramic tube fuses.
- Individual loop boards 5017 with connectors
- Isolated USB interface to avoid generating earth fault if the PC is connected without external isolator.
- Replace jumper links to activate service signal in TLON applications by pushbuttons.
- 5012 and 5015 are Compliant with the latest Australian standards AS7240.2:2018 and AS7240.4:2018.
- Must use software  $\geq$  V2.10.4.

5012 PCB layout and terminations are shown in Figure 8 below.

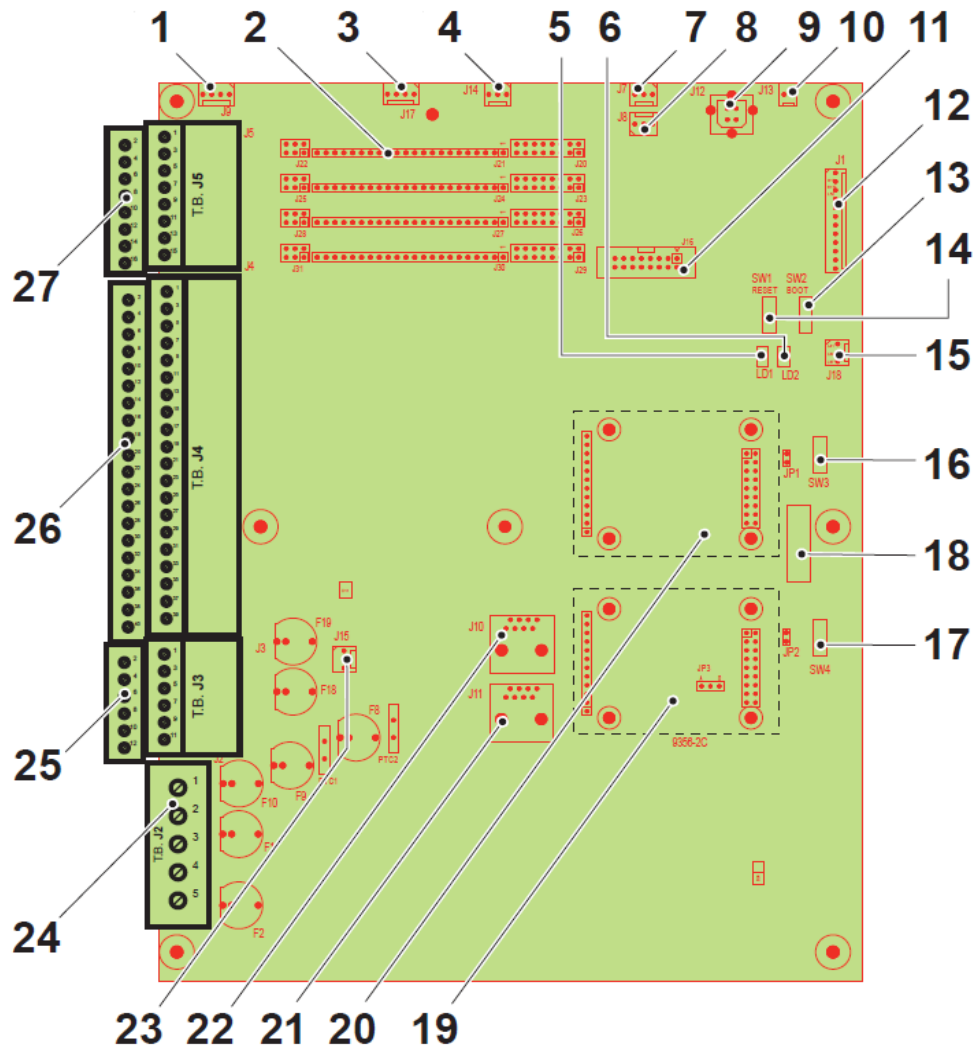

Figure 8 Main Board 5012

**Terminals and connectors designation:**

1. J9, connection for 458X expansion boards
2. Connectors for 4 x Com loop board 5017
3. J17, Not used
4. J14, extra serial channel (not used)
5. LED D1  
Off = TLON board 0 communicating  
Steady = TLON board 1 communicating
6. LED D2  
Steady = Normal  
Off = Watchdog fault or main board in boot mode
7. J7, RS232, for Web-server / Gateway
8. J8, 24V Power supply for Web Server / Gateway
9. J12, Internal connection to USB port (type B), for communication of a PC (EBLWin)
10. J13, for door switch
11. J16, Not used
12. J1, Connection to the MMI board

13. SW2, main board boot<sup>17</sup>
14. SW1, main board restart
15. J18, battery temp. sensor
16. SW3, service button for TLON board no. 0
17. SW4, service button for TLON board no. 1
18. Label for identification
19. Optional, Network board position1 (Secondary network)
20. Optional, Network board position 0 (Primary network)
21. J11, PC connection to TLON board no. 1 (Only used for TLON Manager)
22. J10, PC connection to TLON board no. 0 (Only used for TLON Manager)
23. J15, not used
24. J2, 24VDC input and battery termination
25. J3, 24VDC supply to external equipment
26. J4, Display unit + TLON + ASE connections + programmable outputs, relay outputs & inputs
27. J5, Loops termination

### 5.3.2 Loop Board 5017

The main board 5012 comprises 4 loop boards 5017 mounted and secured with a plate on 5012 main board. The loop board is shown in Figure 9 below

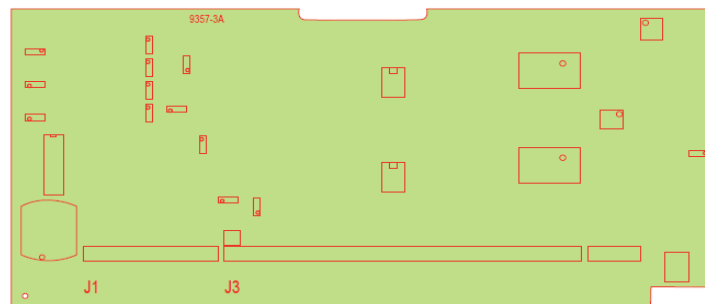

Figure 9 Loop board 5017

### 5.3.3 MMI Board 5015

The MMI board 5015 is mounted on the rear of a 6U face plate behind the front LCD display. The MMI has connection to the main board, LCD, loud speaker and Brooks serial interface module or panel mount printer. The PCB layout is shown in Figure 10 below.

<sup>17</sup> Used to set the main board in "Boot" mode, e.g. in conjunction with software download

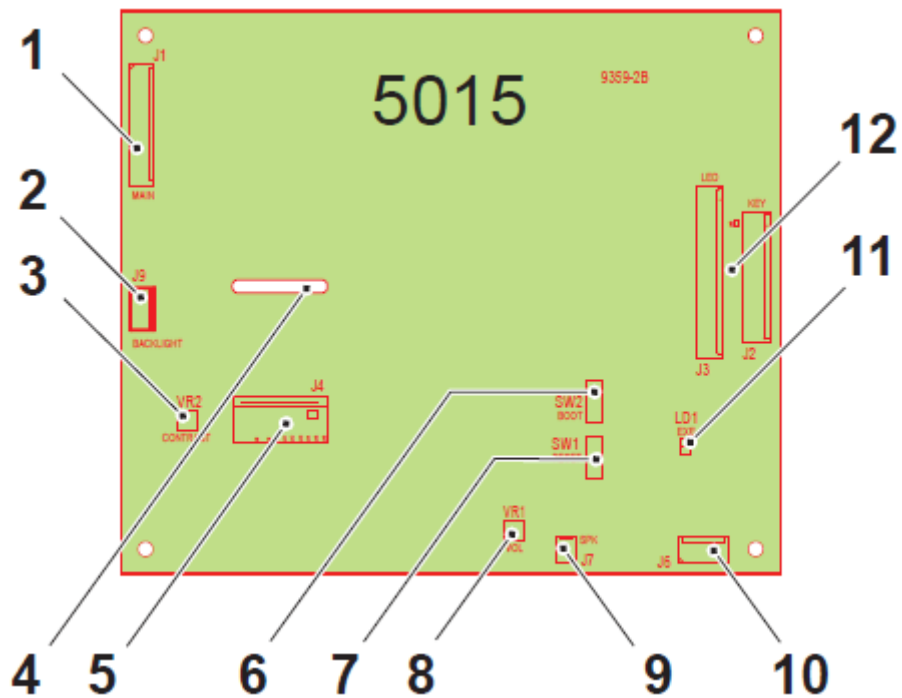

Figure 10 MMI Board 5015

1. J1, Connection to main board 5012
2. J9, Connection to LCD 5038
3. VR2, Potentiometer for LCD contrast
4. Hole for cable connection to LCD
5. J4, Connection to LCD (5038)
6. SW2, MMI board boot for firmware download
7. SW1, MMI board restart for firmware download
8. VR1, Potentiometer for loudspeaker
9. J7, Connection to loudspeaker (5036)
10. J6, Connection to serial interface
11. LED LD1,  
Steady: Normal condition  
Off: Watchdog fault or MMI board in "Boot" mode
12. J2 & J3, Connections to the front 5061 (LEDs and keyboard)

### 5.3.4 Gateway – RS232 Interface

5088 can be used for:

- Presentation of the actual CIE status in a PC using the web browser.
- Send e-mails in case of pre-warning, fire alarm, fault, disablement, test mode alarm and/or service signal
- Remote control and two-way communication. Ten different users and three access levels •
- As a protocol interface to other PC systems etc. The following alternatives are available today:
  - ❖ EBL Talk (RS232 or TCP/IP) is an open protocol, used to transmit and present fire alarm information in a separate PC / system.
  - ❖ ESPA 4.4.4 (RS232) used to transmit and present fire alarm information in a paging system.
  - ❖ SIA (RS232) used to transmit and present fire alarm information in a separate PC application.

- ❖ MODBUS (RS232 or TCP/IP) used to transmit and present fire alarm information in a separate PC application.
- As a protocol interface to a security management system via EBLnet (TCP/IP). EBLnet licence required.
- EBL Graphics, EBLnet licence required

A Config tool is included in EBLWin. It is used for the configuration, which is downloaded to the Gateway via TCP/IP. Also, the software is downloaded via this tool.

### Quick Guide for Downloading S/W and SSD To Gateway

1. First create the SSD for the installation. In menu "System" select "User data" and check-mark the user names / passwords that shall be used for the Gateway as well.
2. Add a Gateway to a Control Unit. (CU menu: Add Gateway...)
3. Do the Gateway configuration.
4. Download the software (Gateway firmware) to the Gateway.
5. Download the configuration to the Gateway.
6. Normally, after 60 seconds the Gateway will automatically restart. If the Gateway is new, do a "power off – power on" restart.

## 5.4 Addressable COM Loop Display Modules

The ancillary 3U rack is designed to be fitted with any combination of display modules as shown in Figure 11 below.



Figure 11 3U Ancillary Modules Face Plate

Any combination of modules in Figure 12 to Figure 15 will fit onto the 3U Ancillary Modules Face Plate shown in Figure 11. This provides maximum flexibility for controlling and indicating of programmable inputs and outputs when used with FT1020G3 Addressable FDCIE loaded with software  $\geq$  V2.4.x.

**Note:** Modules with separate I/O matrix 4582 can be used with software prior to V2.4 whilst modules with built-in I/O matrix circuit e.g. 1205/1206/1211 must be used with software  $\geq$  V2.4.x as well as modules 1204, 1207, 1208, 1209.

Total capacity of a single 3U 19" rack is 420mm, first 20mm is always allocated for power monitor module. The other 400mm can be used to mount multiple different modules. Some modules require 1 space (50mm), others require 2 spaces (100mm). Blank modules are also available to fill up the gaps for any unused modules on the rack.

All modules follow a similar pattern and are designed to be mounted on the 19" metal 3U plate and secured by suitable hardware. A rectangular washer (PCB) is used to help retain the adjacent module. The modules are interconnected by a single ribbon cable part number CA380.

A blank 50mm module is available to cover an unused 50mm module space and another 100mm blank module to cover the unused 100mm module space. Also, a blank 20mm module is available to blank space reserved for the 1204 Power Monitor Module, if required.

The new display modules are versatile and interchangeable modules allowing for quick and easy installation and configuration as shown in Figure 11. The modules are mounted from the rear of the ancillary rack using supplied prolong washer (or small PCB) and fasteners.

The functions and features of the new display modules are shown in Table 12 below.

Table 12 Module specifications

Module No.	Description	Function	Indicators	No. of Add.	Module space
1204	Power Monitor Module	Provide 24V and 5V power to 1200 series modules	Poll, 24V OK, 5V OK	1	20 mm
1205	15 Zone Control Module	Disable zone	Disable, Fault and Alarm LEDs	1	100 mm
1206	4 Fan Control Module	Fan manual control On, Auto, OFF	Fire Mode, Run, Stop, Fault, Phase Fault, On, Auto, Off	1	100 mm
1207	8 Key / 8 LED Control and Display Module	8 programmable Switches (input)	8 Programmable LED's (output)	2	50 mm
1208	4 Key / 8 LED Control and Display Module	4 programmable Switches (input)	8 Programmable LED's (output)	2	50 mm
1209	8 LED Display Module	N/A	8 Programmable LED's (output)	1	50 mm
1210	6 LED Pump Status Display Module	N/A	6 x Programmable LED's (output)	1	50 mm
1211	4 Damper Control Module	Damper control Fire, Auto, Non-Fire	Fire Mode, Fire, Non-Fire, Fault, Power Fault, Fire, Auto, Non-Fire	1	100 mm

All the display modules have a slot in them for the placement of a label for the individual control group of the display module.

#### 5.4.1 Power monitor and loop connection module 1204

**1204** Module is designed as an interface point between a rack of display / control modules and a COM loop in the FT1020G3. Only one 1204 required for every 19" ancillary rack and uses a reserved slot (first slot) as shown in Figure 12 below.

**Note:** Rack capacity is 8 single space modules (50mm) or 4 double space modules (100mm). If double space modules e.g. 1205, 1206 or 1211 to be mounted on the ancillary rack, only 4 modules can be mounted.

The **1204** supplies power to the display modules mounted on one 19" rack plate using the ribbon cable CA380, the power is protected from excessive current via auto-resettable fuses on the 1204 PCB. Requires 20mm (4HP) space at the beginning of the ancillary rack and one COM loop address connected via plug-in terminals.

The 1204 has a green polling LED which will flash whenever the module is polled or communicated with the FDCIE as well as LED indicators for the 5V and 24V rail. Should either rail becomes faulty, this will be reported to the FDCIE. The Loop is opto-isolated from the power rail. Each module uses about 4mA of Loop current.



Figure 12 1204 Power Monitor Module

### 5.4.2 Zone Control Module 1205

Each **1205** Zone Control Module consists of a I/O matrix circuit and controls / indicators combined in one PCB specifically configured to provide up to 15 individual zone alarm and zone fault indicators as well as a disablement control with indicator to indicate switch activation. The module is mounted on the 19" ancillary rack in the FDCIE cabinet but it is also possible to connect a rack of modules remotely via a COM loop and 24V supply.

Each 1205 comprises 3 parts: PCB, plastic spacer and decal label.

The **1205** module is programmed in EBLWin as an "I/O matrix board 4582" for "Zone Control". Requires 100 mm (20HP) space on the ancillary rack. Internally connected to COM loop 0 similar to expansion boards 458x but it can be connected to any other loop. Refer to the limitation of I/O matrix shown in Table 3 page 15.

The Zone Control Module is used as a simple and easy access to disable (isolate) individual zones for service and maintenance purposes as well as providing zone alarm and zone fault indications. The front display layout is shown in Figure 13 below.

The disable control allows a specific zone to be temporarily disabled. This is typically used where building works or maintenance procedures are being carried out in a localised area of a building.

For programming and more information refer to technical datasheet TDS059 and to drawing no. F822 in Figure 24 page 177.

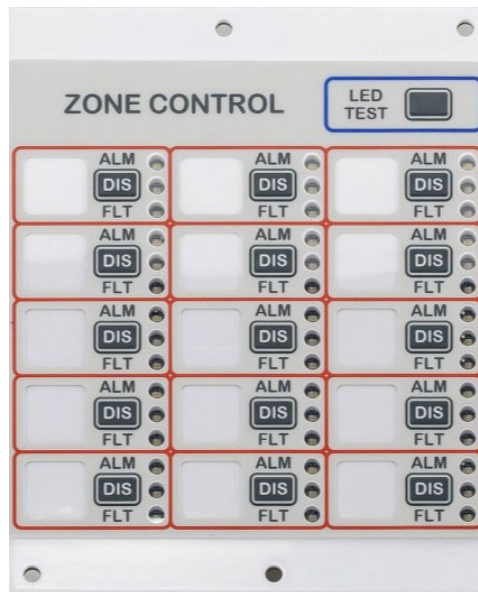

Figure 13 1205 Zone Control Module

### 5.4.3 Fan / Damper Control Module 1206 / 1211

The **1206** is a Display and Control Module to control and indicate the status of four Fans. The 1206 is programmed in EBLWin as an "I/O Matrix board 4582" for "Fan / Damper Control".

**1211** is a Display and Control Module to control and indicate the status of four Dampers. 1211 module utilises the same 1206 PCB with different label and functionality. The 1211 is programmed in EBLWin as an I/O Matrix board 4582 for "Fan / Damper Control".

Each 1206 and 1211 Require 100 mm (20HP) space on the ancillary rack. 1206 and 1211 can connect to any COM loop 0-3, refer to the limitations of the I/O matrix shown in Table 3 page 15.

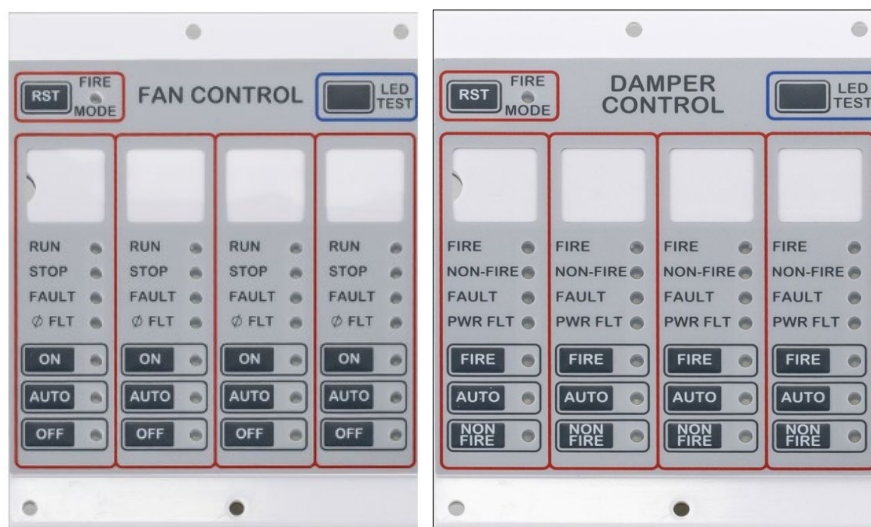

Figure 14 1206 / 1211 Fan / Damper Control Module

Each fan / damper control module consists of an I/O matrix circuit and controls / indicators integrated in one PCB specifically configured to provide fan or damper control and indications. Each 1206 or 1211 comprises 3 parts: PCB, plastic spacer and decal label. Each module can control and indicate the status of up to 4 different fans or dampers. Up to 24 x fan / damper control modules can be used to provide 96 fan or damper interfaces if no other Expansion Boards 458X or zone modules are used.

**Note:** The total number of fan / damper modules must be reduced by one for every other option fitted, e.g. zone module or Expansion Board type 458x.

A fan reset switch is provided to independently restore the fan status to non-alarm condition as required by AS1670.1:2018, section 7 i.e. reset the alarm in the FDCIE will not restore the fans to the non-fire condition until the reset switch is pressed.

Two new features are added in the new 19" rack version:

1. Added a fan phase fault LED for each fan to indicate a phase failure in one of the phases supplying power to the fan. The Phase fail fault indicator conforms to the requirements of AS1670.1:2018 clause 7.15.6. Same LED exists in the damper module to indicate power loss to the damper.
2. A common fire mode indicator is added to each module to indicate general fire alarm.

A remotely located (mechanical services) 4461 module is required for each fan/damper and configured in the control panel using control type "Fire Ventilation" in EBLWin.

For standard fan configuration e.g. smoke exhaust fans, the **standard** mode can be used to program 4461, only one relay is required to start / stop the fan whilst for more configuration options e.g. supply air fans, the **enhanced** mode is used to provide separate relays to start and stop the fan.

Indicators and Controls of the fan / damper modules are described in Table 13 and Table 14 respectively.

**Note:** label of damper control module is different to indicate damper status and controls and configured separately on the EBLWin.

Table 13 Fan indicators and controls

LED indicator & buttons		Indicating
FIRE MODE	General fire mode - Red	Illuminates to indicate general fire.
RUN	Fan running - Red	Illuminates to indicate fan running.
STOP	Fan stopped - Green	Illuminates when the fan is stopped.
FAULT	Fan fault - Yellow	Illuminates when the signal to change the fan status is restored, either via manual override switch or by the FDCIE in Auto mode but the feedback signal confirming the change of state has not been received by 4461 input connected to the fan pressure switch or CT within 30 seconds <b>OR</b> : There is an open circuit in the 4461 supervised input where the feedback from the pressure switch is connected <b>OR</b> The pressure switch is faulty
Ø FLT	Phase fault - Yellow	Illuminates in case of fan power phase failure
ON	LED – Red	Indicates manual start when the “On” button is pressed
	Button	Manual override control to start up the fan manually irrespective of any alarm condition in the FDCIE.
AUTO	LED – Green	Indicates “Auto” position of the button, normal operation
	Button	Pressed to put the fan in “Auto” mode i.e. the fan may run or stop automatically depending on the alarm condition in the FDCIE
OFF	LED - Yellow	Indicates “Off” position of the button, fan stops manually
	Button	Manual override control to stop the fan if it is running irrespective of any alarm condition in FDCIE.

Table 14 Damper indicators and controls

LED indicator & buttons		Indicating
FIRE MODE	General fire mode - Red	Illuminates to indicate general fire.
FIRE	Damper open - Red	Illuminates to damper is opened.
NON- FIRE	Damper close - Green	Illuminates normal status i.e. damper closed.
Fault	Fan fault - Yellow	Illuminates when the signal to open or close the damper is restored, either via manual override switch or by the FDCIE in Auto mode but the feedback signal confirming the change of damper state has not been received by 4461 input connected the damper field control (if used). Or There is an open circuit in the 4461 supervised input where the feedback from the field damper control is connected. Or The damper device supplying damper condition is faulty
POWER FLT	Power fault - Yellow	Illuminates in case of no power controlling the damper
FIRE	LED – Red	Indicates manual control when the “On” button is pressed
	Button	Manual override control to open the damper manually irrespective of any alarm condition in the FDCIE.
AUTO	LED – Green	Indicates “Auto” position of the button, normal operation
	Button	Pressed to put the damper in “Auto” mode i.e. the damper may open or close automatically depending on the alarm condition in the FDCIE
NON FIRE	LED - Yellow	Indicates “Off” position of the button, damper close manually
	Button	Manual override control to close the damper if it was opened irrespective of any alarm condition in FDCIE.

## 5.5 Generic FT1020G3 Display and Control Modules

Each 19” rack mount display / control module comprises 3 parts: PCB, plastic spacer and decal label. The PCB for all display modules is only one PCB but fitted with switches and LEDs to suit different applications. All switches and LEDs are fully programmable in EBLWin as an input (switch) or as an output (LED).

Each display module can be manually addressed with the address setting tool 4414E set to **Advanced Mode (mode 3)**. All Display Panel modules must be configured with software  $\geq$  V2.4.x. to be recognised by the FDCIE.

The generic and display modules are mounted on the ancillary 19” metal rack, up to 8 modules can be connected on one ancillary rack. Each module required to be connected to the monitor card 1204 via a ribbon cable to communicate with the loop and powered with 24V / 5V supply. The ribbon cable is equipped with 10 way socket to plug in the IDC header in each module.

All LEDs in every module can be configured via DIP switch on each module to provide 3 colours; red, green and amber. Even within the same module, different colour indicators can be configured.

Notes: **1207 & 1208**: Require 2 consecutive COM loop addresses per module and will automatically take on the next address.

The four types of the 50mm different display and control modules are shown in Figure 15 below. The functionality and requirements are described in section 5.5.1 to 5.5.4 below.

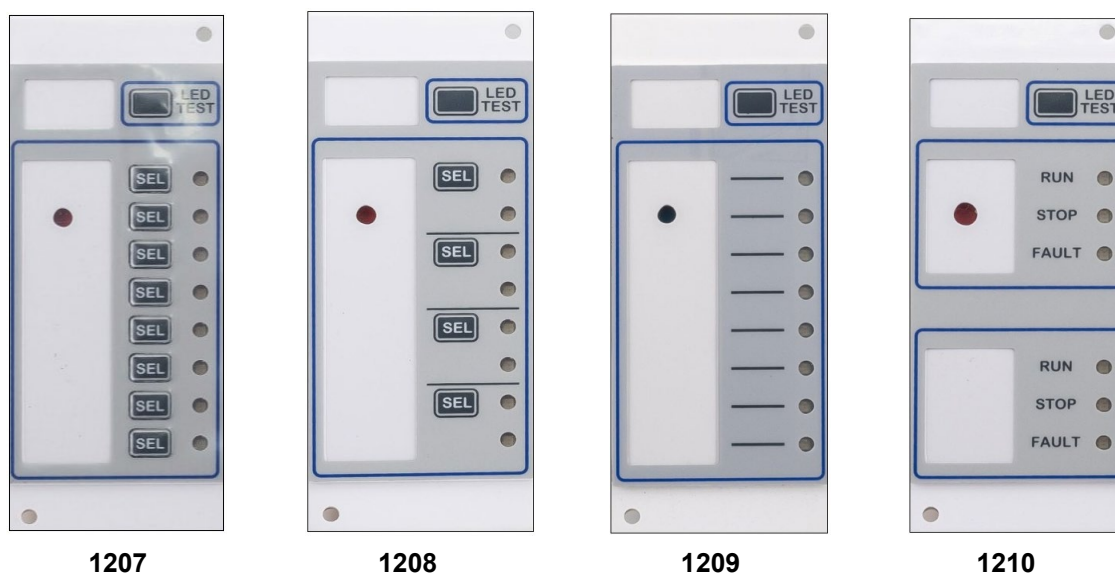

Figure 15 Display and control modules

### 5.5.1 Generic 8 Switches / 8 LED's Display / Control Module 1207

**1207** is a Generic **8 programmable switches** and **8 programmable LEDs** display and control module, programmed as a normal type input (switch) and a normal type output (LED).

The module requires **two** COM loop addresses and one 50mm (10HP) space on the ancillary 19" rack, the second address is automatically allocated. Can connect to any COM loop 0-3, limitation is dependent on max. loop current consumption. DIP switch is provided to change the LED's colour (green, red or amber), refer to the technical datasheet TDS059 for colour setting.

Each switch input can be configured to be latched (toggle) or non-latched (momentarily) and each LED output can be interlocked with the switch input i.e. follow the switch activation or can be activated independently by an output logical expression.

Address setting tool 4414E is used to address 1207 in **Advanced mode (3)**.

### 5.5.2 Generic 4 Switches / 8 LED's Display / Control Module 1208

**1208** is a Generic **4 switches** and **8 LEDs** display and control module. The functionality and programmability of the switch input and LED output are identical to 1207 except the number of switches is 4. 1208 is programmed as a normal type input (switch) and a normal type output (LED).

The module requires **two** COM loop addresses and one 50mm (10HP) space on the ancillary rack. The second address is automatically allocated. Can connect to any COM loop 0-3, limitation is dependent on the max. loop current consumption. DIP switch is provided to change the LED's colour, refer to TDS059.

Address setting tool 4414E is used to address 1208 in **Advanced mode (3)**

### 5.5.3 Generic 8 LED's Display Module 1209

**1209** - Generic **8 LEDs** display module, programmed as a normal type output (LED). The module requires **one** COM loop address and one 50mm (10HP) space on the ancillary rack. Can connect to any COM loop 0-3. DIP switch is provided to change the LED's colour.

Address setting tool 4414E is used to address 1209 in **Advanced mode (3)**

### 5.5.4 Pump status 6 LED's Display Module 1210

**1210** – **6 LEDs** Pump Status Monitor, specialised module to monitor the status of pumps or monitor water tank high / low. Requires **one** COM loop address and one 50mm (10HP) space on the ancillary rack. DIP switch settings can be used to change the LED display colours. Address setting tool 4414E is used to address 1210 in **Advanced mode (3)**

Please refer to The Technical Datasheet TDS059 for full details on DIP switch settings, programming, and installation.

## 5.6 I/O COM loop Field Modules

Three new I/O COM loop addressable field modules are available using software  $\geq$  V2.4.x as shown below:

Module No.	Subassembly no.	Description
1200	SUB997	Single supervised input / single relay output
1202	SUB994	Four Supervised inputs / four relay outputs
1203	SUB991	8 non-supervised inputs / 8 relay outputs

Each module can be fitted in Brooks enclosure BAFME or BAFMES however, if the enclosure is not required the reference will be for the subassembly number as shown in the table above.

The following are some of the field modules 1200, 1202 & 1203 features:

- Compatible with Brooks FDCIE FT1020G3 software  $\geq$  V2.4.x and EBLOne software  $\geq$  V3.6.x.
- Built-in short circuit isolator with short circuit LED indicator.
- Fully supervised input (clean contact) via end of line resistor 10K $\Omega$  (1200 & 1202).
- Flashing green polling LED on each module to indicate valid COM loop communications.
- Relay contacts output with on-board LED indicators, contact current rating is 1A.
- Plug-in connectors to easily terminate the field wiring (1202 & 1203).
- All inputs and outputs are fully programmable via EBLWin configuration tool.
- Low supervising voltage for inputs (3.3 V), only 1200 & 1202.
- All modules conform to AS ISO 7240.18:2018 and AS ISO 7240.17:2015

All units are programmed using the Addressing Tool 4414 or 4414E, the 1203 require 24VDC to be applied in order to address the module. All modules are required to be addressed in the “**Advanced Mode**”. These units must also be configured with EBLWin  $\geq$  V2.4.x for the FT1020G3 to recognise them.

### 5.6.1 1200 Module – SUB997

The module is a single supervised programmable input / single programmable relay output as shown in Figure 16 below. Used where a single device needs to be triggered (output) and a return signal is required to report that the action has been carried out (input), e.g. a sprinkler flow switch.

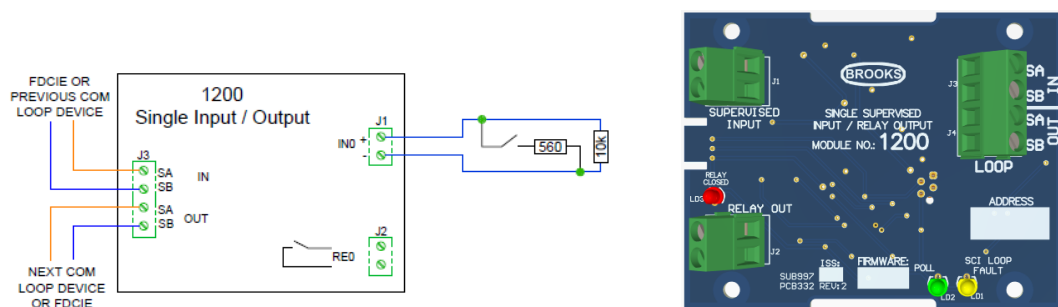

Figure 16 Single I/O 1200 connection and SUB997 PCB

The 1200 module or SUB997 requires only **one address** on the COM loop. The relay type in this module is a latching relay which reduces the current consumption supplied by the COM loop. The relay must be restored to the normal status i.e. reset.

### 5.6.2 1202 Module – SUB994

1202 or SUB994 comprises four programmable supervised inputs and four programmable relay outputs. The functions and programming of each input or output is identical to 1200 I/O module. Connection is similar to 1200 module shown in Figure 16 above, the PCB and connection diagram are shown in Figure 17 below. The supervised input requires 10K end of line resistor.

The relays used in 1202 are also latching relay type i.e. remains in active condition until normal status is restored). The module doesn't require external 24V supply and powered from the COM loop.

The module requires one COM loop address set by 4414E in "Advanced Mode (3)".

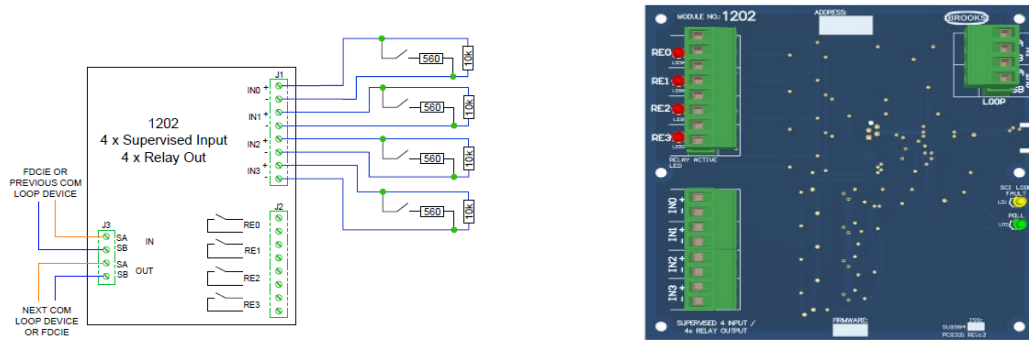

Figure 17 4/4 1204 I/O SUB994

### 5.6.3 1203 Module – SUB991

1203 – SUB991 I/O unit is designed to provide 8 x programmable non-supervised inputs and 8 x programmable relay outputs, no end of line resistor required. The relays are non-latching relays which requires external 24V<sub>DC</sub> supply. Connection is similar to 1200 shown in Figure 16 page 39 but inputs are not supervised. The physical SUB991 board is shown in Figure 18 below. 1203 requires two consecutive addresses on the COM loop set in "Advanced Mode (3)".

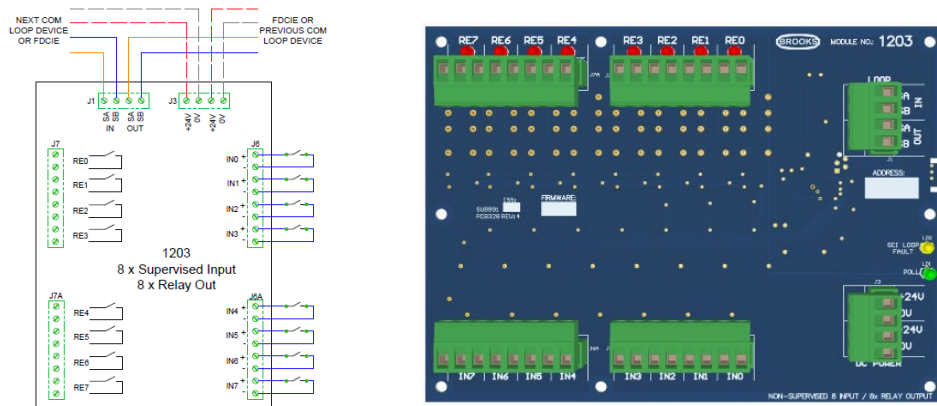

Figure 18 8/8 1203 I/O SUB991

**Note:** Refer to Technical Datasheet TDS053 for full details on programming and installation.

## 6 User Data & Access Levels

### 6.1 User Data

FT1020G3 supports different levels for different users. To log on to an FT1020G3, a **User name** and **Password** are required. Ten different User names with individual Passwords can be used.

Via EBLWin (menu "System"), ten different User names with individual Passwords can be defined in the "User data" dialog box. One of three different levels / types can be selected for each user name. User name must be used to log on to an FT1020G3 and/or for Gateway access.

The default user names and passwords are shown below:

	Username	Initials	Password	Fire alarm access	WEB-server access	Access type
▶	Information only	IO	000000	<input checked="" type="checkbox"/>	<input checked="" type="checkbox"/>	Information only
	Building officer	BO	111111	<input checked="" type="checkbox"/>	<input type="checkbox"/>	Building officer
	Service personnel	SP	222222	<input checked="" type="checkbox"/>	<input type="checkbox"/>	Service personnel
				<input type="checkbox"/>	<input type="checkbox"/>	Information only
				<input type="checkbox"/>	<input type="checkbox"/>	Information only
				<input type="checkbox"/>	<input type="checkbox"/>	Information only
				<input type="checkbox"/>	<input type="checkbox"/>	Information only
				<input type="checkbox"/>	<input type="checkbox"/>	Information only
				<input type="checkbox"/>	<input type="checkbox"/>	Information only
				<input type="checkbox"/>	<input type="checkbox"/>	Information only

**Note 1:** The default user names and passwords can be changed in EBLWin. Also, the Fire alarm access and Gateway (if used) access columns have to be filled in (check boxes), depending on how the user names and passwords should be used.

**Note 2:** In a new FDCIE. (i.e. before downloading any Site Specific Data), only user "0" is available. No password is required and you have access to all menus. After download of SSD the downloaded user names and passwords will be valid.

#### 6.1.1 User Name

Up to ten users, 0 to 9, may be programmed. By default, three users are available:

- 0 = Information only
- 1 = Building officer
- 2 = Service personnel

#### 6.1.2 Password

Each user has a password for an access level e.g. "Information only", "Building officer" or "Service personnel".

##### Change of Password

Normally the user names and passwords are downloaded / changed via EBLWin and SSD download. A logged-on person (user name) can also change his/her password via menu H10.

If the valid password is unknown, a saved SSD can be downloaded via EBLWin. If a saved SSD is not available, a new SSD with the correct password must be downloaded..

The password can be changed via MENU H10 but the old password must be known, See Chapter 31, page 169.

**Note:** Brooks recommend a copy of the SSD to be given to the building manager. If the password has changed, it can't be restored, a new SSD must download to the FDCIE.

### 6.1.3 Password for Gateway Access only

Normally a password consists of 6 digits. This allows the same user to gain access to the control unit as well as to the Gateway, if both are selected.

If a user should have access to the Gateway only, it is possible to select a stronger password. It consists of 6 to 10 characters and digits, letters can also be used.

**Note:** The letters are case sensitive

## 6.2 Access Levels

To use the keypad in FT1020G3 and get access to the menus, it is necessary to log on with a user name and password for level 2A, 2B or 3A.

Before any SSD is downloaded (e.g. in a brand-new control unit), only "0" is shown and no password is required. After SSD download, the downloaded user names and passwords will be valid.

### 6.2.1 How to Log On

1. Open the acrylic door with 003 key. Press the soft key **Menu**.
2. On the keypad, press 0, 1, 2 - - 8 or 9 to select a user. Press .
3. Type the password for that user. (Six digits. \* \* \* \* \*)







After typing a correct password, the main menu list with the available menus will be displayed. For "0", Information only, no password is required.

#### **NO ACCESS!**

No access will be shown if the entered password was incorrect. Try again.

**Note:** After three attempts of entering wrong passwords, the log in function will be blocked for one hour for each user name respectively.

### 6.2.2 Navigation / General Procedures

- Scroll in lists or menus with  .
- Press   to toggle between different choices.
- Press soft key  to toggle between different functions.
- Press  to select / accept.
- Press the digits on the numeric keypad to select a menu or enter data.
- A successful disablement is indicated by a beep and a "√". It will also be shown in the Re-enable list.
- A non-successful disablement is indicated by another beep and a "X".
- To leave the menu system, press the soft key **ESC**.
- To logout, close the door.

**Quick jump** can be used within each menu, e.g. press "6" for a quick jump to menu H6.

You will be automatically logged out 15 minutes after the last action, and directly when you close the door. A new login is then required. If you leave the menu system without closing the door, you have access to the menu system again only by using the soft key "Menu". A new login is not required.

## 6.3 User Level

Each user level type has access to specific menus according to Table 15 below.

Table 15 Levels of access

Information only	Building Officer	Service Personnel
H4 Present system status	H1 Perform monthly test	H1 Perform monthly test
H6 Display faults	H2 Disable or re-enable	H2 Disable or re-enable
H9 Interlocking outputs and inputs	H3 Set calendar and clock	H3 Set calendar and clock
H10 Change password	H4 Present system status	H4 Present system status
	H6 Fault acknowledge	H5 Service
	H7 Perform zone test	H6 FAULT Acknowledge
	H9 Interlocking outputs and inputs	H7 Perform zone test
	H10 Change password	H8 Maintenance
		H9 Interlocking outputs and inputs
		H10 Change password

### 6.3.1 User Access Levels

The user names and type of access permitted are shown in Table 16.

Table 16 Access Levels and user names

User level	User level type	Required action / equipment	Access to
1	None	None (Door closed).	View indications and controls
2A	Fire service personnel	Open door (003 key required).	Fire alarm response via fire brigade panel, fan / damper control, OWS, hot buttons zone disablement and buttons on 1200 display modules.
2B	Information only	003 key + log on as "Information only"	Same as 2A + keypad. Menu H4, H6 <sup>18</sup> , H9 <sup>19</sup> & H10
2C	Building officer	003 key + log on as "Building officer"	Same as 2B + keypad. Menu H1-H4, H6, H7, H9 & H10
3A	Service personnel	003 key + log on as "Service personnel"	Same as 2C + keypad. Menu H1-H10
3B	Senior Service Personnel	003 Key + PC + Hardware key (5094) + EBLWin	SSD & S/W download
4	System Engineer	003 Key + PC + EBLWin + special password	SSD & S/W download + reset of alarm counter

### 6.3.2 User level 1





With the door closed, no access is available, just viewing the indicators of the front display of the main control panel and any other feature.

### 6.3.3 User level 2A

After the door has been opened using 003 key ("Door open"  symbol in the symbol area), you gain access to level 2A as shown in Table 16 above, the designated fire brigade personnel will have access to the pushbuttons inside the red boarder . The user can log on to gain access to level 2B, 2C or 3A.

<sup>18</sup> Information only, i.e. the faults cannot be acknowledged.

<sup>19</sup> Menu H9/C1 only.

Push button	Operation/function
P1 	Silence buzzer in FT1020G3
P2 	Silence all alarm devices (OWS or sounders).
P3 	Reset fire alarms
P4 	Disable active alarm
P9 	Scroll / browse through the active queued alarms
OWS	OWS controls, if fitted
AS1668 Fan / Damper Control	Manual override of AS1668 fan or Damper controls, if fitted
Zone Disablement	Quick access to zone disable / re-enable, if fitted
19" Rack Display/control modules	Access to 19" rack control buttons

### 6.3.4 User level 2B

With the door opened, you have access to level 2A and after log on as "Information only" (level 2B), the following menus are accessible:

H4 Present system status
U1 Disablement
U2 Disablement by time channel
U3 Open doors
U4 Sensor values
U5 Sensors activating SERVICE signal
U6 Technical warning
U7 Event log
U8 Information
H6 Display Fault, <b>Note:</b> <i>Information only</i>
H9 Interlocking outputs and inputs
C1 Activated interlocking outputs / inputs
H10 Change password (In this case for "Information only")

### 6.3.5 User level 2C

With the door opened, you have access to level 2B and after log on as "Building officer", you gain access to level 2C as shown in the following menus:

Same menus as in access level 2B <b>Plus</b> the following:
H1 Perform monthly test
H2 Disable or re-enable
B1 Zone or Zone / Address
B2 Output
B3 Output type
B4 Alarm devices
B5 Routing equipment

B6 Alert annunciation function
H3 Set calendar and clock
H4 Present system status
U1 Disablement
U2 Disablement by time channel
U3 Open doors
U4 Sensor values
U5 Sensors activating SERVICE signal
U6 Technical warning
U7 Event log
U8 Information
H6 FAULT Acknowledge
H7 Perform ZONE TEST ("Test mode")
H9 Interlocking outputs and inputs
C1 Activated interlocking outputs / inputs
C2 Activate / deactivate interlocking output
C3 Disable / re-enable interlocking output
H10 Change password (In this case for "Building officer".)

### 6.3.6 User Level 3A

With the door opened, you have access to level 2C and after log on as "Service personnel", you gain access to level 3A as shown in the following menus:

Same menus as in access level 2C <b>plus</b> the following:
H5 Service
A1 Calibration of supervised outputs
A2 Sensitive fault detection mode
A3 Service mode for COM-loop
A4 Display current consumption in Control Unit
A5 Display current consumption on COM-loop
A6 Display statistics for communication
A7 Activate address setting mode for DU
A8 Setup wireless detectors
A9 SSD information
H8 Maintenance
S1 Disable / Re-connect loop / zone line input
S2 Acknowledge SERVICE signal
S3 Clear weekly average
S4 Test of alarm devices
S5 Safe shut down of Control Unit
S6 Activate address in alarm mode
S7 Synchronize the Control Units
S8 Activate / Reset outputs
H10 Change password (In this case for "Service personnel".)

### **6.3.7 User level 3B**

Used by senior service engineers when a PC (i.e. EBLWin) is to be connected to FT1020G3 for backup (upload), download of Site Specific Data and/or download of software. Level 3B menus access is similar to level 3AC.

EBLWin require an EBLWin key (5094) to be plugged in the PC.

### **6.3.8 User level 4**

Used by system engineers or by personnel authorised by the manufacturer for re-initialisation (reset) of the alarm counter, change software configurations, on-line status checking, etc. An EBLWin key (5094) is required to be plugged in the PC.

## 7 Technical Number / Presentation Number

### 7.1 Technical Number for COM Loop Units

The technical number “NNNNNN” is used when programming any unit connected to the COM loops.

Technical number is also used to identify which unit has generated a fault.

NN	N	NNN
<b>00-29</b>	<b>0-3</b>	<b>001 - 253</b>
The control unit addresses (numbers), don't have to be in sequence. When 5090 network card is used, the control unit number is set with a PC SW “TLON Manager”. When 5040 network card is used, the control unit number is set by EBLWin, only with software V3.6 for both options fibre optic or copper.	COM loop number	The technical address on the COM loop. The addresses don't have to be in sequence. The connections on the COM loop don't have to be in sequence. The address for each unit is set with the address setting tool 4414E.

**Notes:**

\* Maximum of 1012 COM loop (technical) addresses can be used in one Control Unit. Address 000 cannot be used, the total number of addresses is 4 x 253.

\* The COM addresses is reduced to 253 per loop due to allocating two addresses in every loop for auto addressing.

\* A brand new detector is factory set to COM loop (technical) address 000. If a detector is connected on a COM loop without setting up an address (001 – 253), the detector LEDs will blink every second, indicating that the detector has not been addressed.

### 7.2 Presentation Number

For each fire alarm point / input / zone, a presentation number NNN-NN has to be programmed.

The presentation number is shown in the FDCIE display and the touch screen display units 5054 to identify the point / zone activating fire alarm. It is also used to disable / re-enable fire alarm points / zones via the menu and as a trigger condition in the control expressions to activate programmable outputs.

Together with the presentation number, a user definable 40 characters text message (alarm text) can be displayed (if programmed).

NNN	NN
<b>001-999</b>	<b>00-99</b>
Zone number	01 – 99 = The address within the zone. 00 = Only the zone number will be displayed, e.g. used for conventional zone line inputs.

**Note:** Zone 999 can be used as a pseudo zone number to enable the programmers to add a logical expression to an output in order to turn on this output without activating a general alarm. Normally used in carpark and jet fan applications.

## 8 Silence Alarm Devices

In FT1020G3 front membrane, the push button "**SILENCE ALARM**" (P2) in the fire brigade panel can be used to silence the warning devices, refer to Figure 3 page 17.

When the alarm devices are activated and the push button "**SILENCE ALARM**" is pressed during a pre-warning, a fire alarm <sup>20</sup> or a Co-occurrence alarm, the following will occur:

- The symbol  is shown in the display, to the right of the "Soft key" area.
- Activated outputs programmed for OWS or sounders (any warning device type "Alarm devices"), will be silenced.

In case of a new alarm or if the push button "**SILENCE ALARM**" is pressed again, the fire alarm devices will automatically re-sound.

In EBLWin (system properties), the optional check box "*Alarm devices does not resound for each new alarm*" cannot be used in the Australian convention as this is a violation to AS4428.3.

In the NZ convention, the function is already implemented in the firmware i.e. not required.

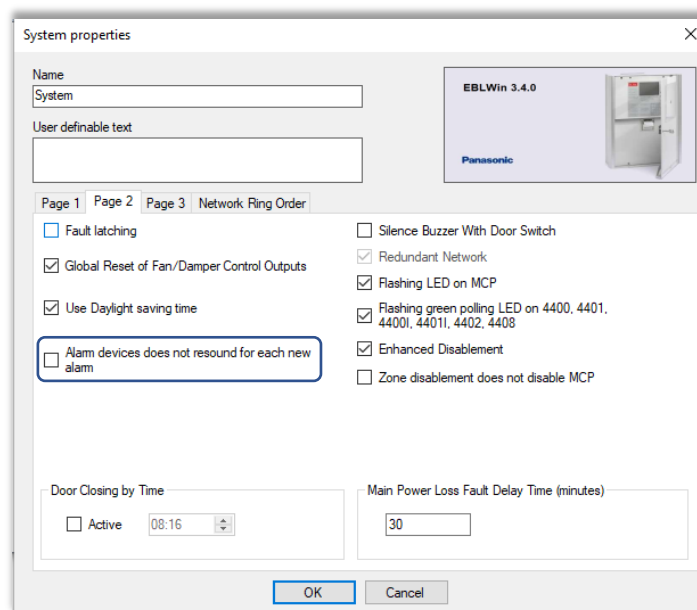

The "FIRE" LEDs will indicate steady instead of blinking when the alarm devices are disabled.

<sup>20</sup> In the New Zealand convention "Acknowledged alarm" (ACK) as well.

## 8.1 SILENCE ALARM (inside switch)

**Note:** The functions in this chapter are used only in the New Zealand convention.

The button "SILENCE ALARM" (P2) is called inside switch, it operates slightly different in the NZ convention as shown in the following section.

The button SILENCE ALARM (inside switch) toggles between two states:

- **Alarm devices disabled**  
when the button is pressed, all programmable outputs of type "Alarm devices" are isolated, i.e. sounders, OWS, strobes, VAD's etc. and prohibits new alarms from activating the warning devices.
- **Alarm devices not disabled**  
when the button is pressed again, all programmable outputs of type "Alarm devices" will be enabled, i.e. any alarm can activate the warning devices.

If the "SILENCE ALARM" button (inside switch) is left in its isolated state when the FDCIE door is being closed, the buzzer will beep continuously and the message "**Silence switch left active**" will be shown in the display. This feature is required in NZS4512 standard to ensure that the door cannot be closed while the alarm devices are isolated. For priority order see chapter "The information area priority order" page 21.

**Note:** The "SILENCE ALARM" button on the front display has no function if the "Silence alarms" Bulgin key in the FT1020G3 cabinet or in the remote fire brigade panel (see below) is turned to the "Silence Alarms" position.

## 8.2 NZ FB "Silence Alarms" Bulgin key (outside switch)

The **New Zealand FB "Silence Alarms" Bulgin key switch** is connected to NZ mimic application board via a programmable input in the IO matrix board 4582 with the trigger condition "NZ Silence switch".

The fire brigade Bulgin key switch can be in only two states:

1. **The Bulgin key switch is turned ON** (from non-activated to activated state).
  - a. All programmable outputs of type "Alarm devices" are disabled. The "SILENCE ALARM" switch in FT1020G3 front display (see above) has no function.
  - b. LEDs "Fire" (on FT1020G3 front display) changes from blinking to steady (continuous)<sup>21</sup>.
  - c. The FDCIE buzzer is silenced.
  - d. A fault is generated<sup>22</sup> "**FAULT: FB Silence switch active**"
2. **The Bulgin key switch is turned OFF** (from activated to non-activated state).
  - a. The fault "**FAULT: FB Silence switch active**" will be Serviced
  - b. Any "Alarm" or "Acknowledged alarm" will be automatically disabled (isolated), i.e. it must be re-enabled via menu H2/B5 and is indicated by LED "General disablement" on the FDCIE front.
  - c. Any "Alarm" or "Acknowledged alarm" will automatically change state to "Isolated alarm" (see below) and in the fire alarm list (presented in the display) "**Alarm**" or "**Acknowledged alarm**" will be replaced by "**Isolated alarm**".

<sup>21</sup> This is valid also if the fire alarm is activated after the Bulgin key switch (outside switch) is turned ON (Silence Alarms position).

<sup>22</sup> The fault (defect) in the NZ convention is always non-latched, no need to be acknowledged via menu H6.

An example:

First alarm: 002-03	Alarm number 1 (of 1)
<b>Isolated alarm</b>	
Zone	Address
<b>002-03</b> SMOKE	
User definable alarm text for 002-03.	
<b>Menu</b>	

## 9 Disable / Re-enable Alarm Devices

---

Outputs programmed for sounders or OWS<sup>23</sup> i.e. type "Alarm devices", can be **collectively** disabled for all control units during Fire alarm or Alert Annunciation alarm, this is done via menu H2/B4. The disablement is indicated by LED **Fault / Disablements "General disablements"** (L10) and **"Alarm devices"** (L11), which are steady ON.

In case of a fire, the sounders or OWS will **remain** disabled, i.e. the alarm devices will not sound until they are re-enabled again via menu H2/B4.

**Note:** Outputs of type "Alarm devices" cannot be individually disabled, not even via menu H2/B2 "Disable or Re-enable Output".

See also chapter "Test of alarm devices" (H8/S4), page 156. All outputs of type "Alarm devices" for a specified or all Control Units, can be activated for an alarm device test.

---

<sup>23</sup> Including Addressable siren 4487, Addressable sounder base 3379, Addressable light indicator 4383, Wireless smoke detector 4611, and all Visual Alarm Devices 448X.

## 10 "SILENCE BUZZER"

The **buzzer** in FT1020G3 will sound for:

- Fire alarm<sup>24</sup> (0.4 / 0.4 sec.)
- Co-occurrence alarm (2-zone or 2-unit dependent fire alarm): When only one zone or one zone / address (alarm point) is in alarm status (0.8 / 5 sec.)
- Pre-warning (0.8 / 5 sec.)
- Quiet alarm (0.8 / 5 sec.)
- Fault (continuous)
- Disablements and Faults (1 sec. directly after the door to the FDCIE is closed.)
- Activated interlocking input (0.8 / 0.8 sec.), if this option is selected via EBLWin.
- Activated technical warning (0.5 / 10 sec.), if this option is selected via EBLWin.
- Delayed alarm

Press "SILENCE BUZZER" button to silence the buzzer.

In case of a new alarm or if the push button "SILENCE BUZZER" is pressed again, the buzzer will automatically re-sound.

### 10.1 Silence buzzer by open door

In EBLWin, the function "Silence Buzzer by Door Switch" can be selected. The buzzer will then be disabled as long as the FT1020G3 cabinet door is open.

### 10.2 Silence buzzer by the "FB Bulgin Key"

**Note:** Valid only for the New Zealand convention.

When the **New Zealand FB "Silence Alarms" Bulgin key switch** (outside switch) is turned ON (i.e. "Silence Alarms" position) the buzzer is silenced until the Bulgin key is turned to the "Normal" position.

If there is a fault or disablement whilst the door to FT1020G3 is closed, the FT1020G3 buzzer will sound continuously directly after the door is closed, the fault and disablement messages will be shown in the display.

**Note:** In the New Zealand convention, if any of the outputs for routing equipment ("Fire Brigade TX" and "Fault TX") or outputs for alarm devices is disabled when the door of FT1020G3 is being closed, the buzzer will sound continuously immediately after the door is closed. "Alarm routing equipment left isolated", "Fault routing equipment left isolated" and "Silence switch left active" will be shown in the LCD. This information has higher priority than the normal fault messages and disablements.

<sup>24</sup> Incl. Heavy smoke/heat alarm, AA alarm and Acknowledged alarm (New Zealand only).

---

## 11 Disable or Re-enable Output

---

All control outputs (except outputs of type "Alarm devices") can be **individually** disabled via menu H2/B2:

- Loop unit xxxxxx output x
- Control unit xx Sx
- Control unit xx Rx
- Control unit xx Expansion Board x output x

This is indicated by LED **Fault / Disablements** "General disablements" (L10). They will remain disabled until re-enabled again via menu H2/B2.

See also chapter Output Type (H2/B3), page 118.

See also chapter "Activate / Reset Outputs (H8/S8)", page 163. An output can be activated for an output test, even if it is disabled.

---

## 12 Disable/Re-enable Control Outputs<sup>25</sup>

---

All control outputs programmed as type:

- Control (general)
- Ventilation (Smoke control activated)
- Extinguishing system (Fire protection activated)
- Interlocking

..... can be collectively disabled via menu H2/B3 for a specified control unit or all control units. This is indicated by LED Fault / Disablements "General disablements" (L10).

They will remain disabled until re-enabled again via menu H2/B3.

See also chapter "Activate / Reset Outputs (H8/S8)", page 163. An output can be activated for an output test even if it is disabled.

See also chapter "Activate / Deactivate Interlocking Output (H9/C2)", page 166. An interlocking output can be activated for an output test, even if it is disabled.

---

<sup>25</sup> Terminology of Extinguishing and Ventilation has been changed in the fire brigade panel standard since AS4428.3:2010 as well as the latest standard AS4428.3:2020. Extinguishing re-named to "Fire Protection Activated" and Ventilation to "Smoke Control Activated".

## 13 “DISABLE” Button

When the push button “**DISABLE**” is pressed whilst there is an active alarm in the FDCIE, all outputs configured for the device(s) or zone(s) in alarm, will be disabled (**must be preceded by “SILENCE ALARM”**). This is indicated by the “General disablement” LED.

The “**DISABLE**” push button is provided within the fire brigade section on the front display to enable the fire brigade personnel to disable (isolate) an active alarm such as a zone of addressable sensors, conventional zone or individual addressable device.

A single operation of the “**DISABLE**” button whilst there is an active alarm and the “SILENCE ALARM” button is pressed first, will initiate the following:

- Disablement of all zones in alarm and/or addressable devices in alarm.
- Illuminate the “General Disablement” LED.
- Disablement of all the outputs configured for zone(s) or device(s) in alarm.

As a result of an alarm, the activated output indicators will not clear automatically after disablement. A subsequent reset operation is required to restore the FDCIE to the normal condition.

**Note:** The “Disable” button will not function unless the “SILENCE ALARM” button has been activated first as required by AS4428.3<sup>26</sup>.

Following an alarm in FT1020G3, the disable function sequence operates as follow:

1. Press “**SILENCE BUZZER**” to stop the panel buzzer.
2. Press “**SILENCE ALARM**” button to stop sounding the warning devices.
3. Press “**RESET**” button to reset active alarms.
4. If the alarm activates again, press “**SILENCE BUZZER**” then press “**SILENCE ALARM**” button.
5. Press “**DISABLE**”, the alarm point, zone or MCP in alarm will be disabled and the “General Disablements” LED turns ON. Panel will revert to normal condition

<sup>26</sup> This function is not required in NZ convention.

## 14 Open Door

A standard 003 key is used to open FT1020G3 acrylic door to gain access to the front membrane and other optional modules e.g. OWS, zone disable, AS1668 fan / damper control, ancillary modules, etc.

If any door in the system (any Control Unit) is open, the following symbol is shown in the display's symbol area: 

Door open may be programmed via EBLWin to disable any external VAD or VAD/strobe combination located at the designated building entry point. See also chapter Open doors (H4/U3), page 129.

### 14.1 Disable Routing Equipment with Door Switch

**Note:** **Do not use** the door open function to disable the routing equipment. This option cannot be selected in both Australia and New Zealand, it is a violation to AS4428.3 and NZS4512.

In EBLWin the following options are available to program:

Disable Routing Equipment By Door Switch

- None
- Any Control Unit Door
- Any Door

**Note:** None is the only option to select as the fire brigade disable function must be done via the ASE.

### 14.2 Silence Buzzer by Door Switch

In EBLWin the following can be programmed:

Silence Buzzer With Door Switch

The FT1020G3 buzzer will be turned off as long as any FT1020G3 door is open.

## 15 Alarm Types

In case of a fire, analogue detectors (sensors), conventional smoke and/or heat detectors, manual call points and programmable inputs can activate **fire alarm**<sup>27</sup>.

A fire alarm could be an **Alert Annunciation alarm**, i.e. the activation of the routing equipment (Fire Brigade TX) is delayed during an acknowledgement time and an investigation time. The analogue detectors can also activate other types of "alarm" i.e. **Pre-warning** and **Heavy smoke alarm / Heavy heat alarm**. "Two unit dependent" addressable alarm points (normally only smoke detectors) and "2-zone dependent" zones, can activate a **Co-incidence alarm**.

**Quiet alarm** is used to activate outputs, based on smoke detected by a smoke detector, without activating a fire alarm in the system. This alarm type can be used in AS1668 fan control and other applications that require a non-latching / non-brigade call alarm.

**LAA alarm**<sup>28</sup> (Local Alarm Acknowledgement), the function is similar to the alert annunciation function and normally used to manually control the brigade call alarms. If the LAA function is used, during the acknowledgment and the investigation periods, there will be an indication in the FDCIE display and the Fire Brigade TX will be delayed. The LAAF function requires a Local Alarm Acknowledgement Unit (LAAU 4445), a smoke detector (sensor) 4401 or 4401I and sounder base 3379. During the Acknowledgement time and the Investigation time respectively, there will be an indication in the FDCIE display.

**Acknowledged** and **Isolated alarms** are fire alarm functions used only in only New Zealand convention.

Regarding the different alarm types, etc., see the following chapters.

In the following chapters, all different alarm types are described. The illustrations in this document show the essential information and may not look exactly as shown in the display.

### 15.1 Pre-warning

Activation of Pre-warning is an option, if required has to be enabled via EBLWin for the Control Unit.

**Note:** Pre-warnings activated in any Control Unit in the system will always be presented in all Control Units. Any programmable outputs in the system (with trigger condition pre-warning) will be activated (if not disabled).

An analogue detector generates a pre-warning at a lower alarm level than the fire alarm level. Pre-warning can be used when an early warning and/or an early action is required (e.g. a "soft" computer shut down). Normal alarm devices (output type "Alarm devices"), routing equipment, etc. will not be activated.

Any programmable input can also be used to activate a pre-warning, e.g. for a high sensitivity smoke detection system. Aspirating smoke detector programmed for detection type "And with pre-warning" will activate a pre-warning for "alarm" from one detection area only.

See "Help" in EBLWin to access the Planning instructions of the system.

**In case of a pre-warning, the following will occur:**

- The buzzer in the FDCIE sounds 0.8 sec. each 5th sec. (0.8 / 5 sec.).
- Outputs programmed for pre-warning are activated.
- In the FDCIE display, a presentation number (zone/address) is shown (for the first pre-warning).
- In the FDCIE display, a user definable text message (= the alarm text for fire alarm) is shown (if programmed).

<sup>27</sup> In the New Zealand convention only, a Fire alarm (ALARM) can be "changed" to an Acknowledged alarm (ACKNOWLEDGED) or an isolated alarm (ISOLATED).

<sup>28</sup> LAAF is the Local Alarm Facility as per the previous model AAF (Alarm Acknowledgement Facility). Local Alarm Acknowledgement Unit operates similar to the discontinued Alarm Acknowledgement Module AAM.

Example; pre-warning zone 123, address 45 (within zone 123):

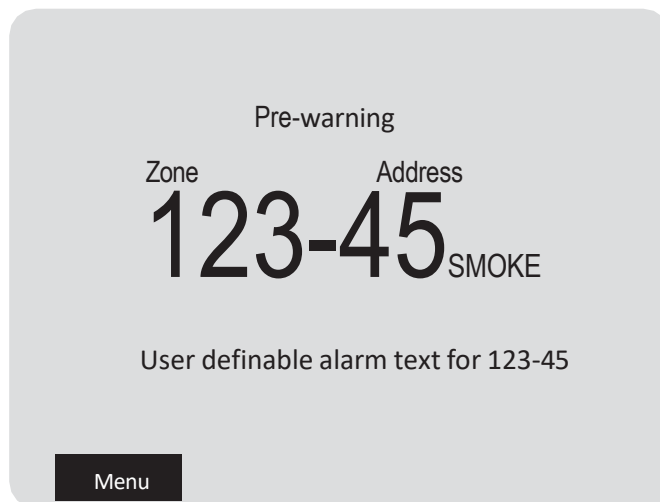

"SMOKE" after the presentation number is automatically added depending on the type of alarm point (i.e. SMOKE, HEAT, MULTI or MCP).

**Note:** The text "Menu" for the soft key "P5" is visible in the display, only if the door in the FDCIE is open.

If more than one pre-warning is activated, the LEDs "SEVERAL ALARMS" (L6) are blinking and the pre-warnings will be automatically scrolled (every five seconds). Pre-warnings are automatically reset, see chapter "Alarm reset", page 67.

## 15.2 Fire Alarm

The FT1020G3 system can support up to 15360 fire alarms but only 512 fire alarms can be presented in the FDCIE display. If more than 512 fire alarms are activated, no additional fire alarms can be displayed until one or more of the first 512 fire alarms are reset.

Normally all fire alarms will be presented in all control units (default) but it is possible to have selective alarm presentation, i.e. only fire alarms from selected Control Units will be presented in the Control Unit, set in EBLWin for each Control Unit.

See also chapter "The information area priority order", page 21.

### The following occur in case of a fire alarm:

- The buzzer in the FDCIE sounds 0.4 sec. each 0.4<sup>th</sup> sec. (0.4 / 0.4 sec.).
- LEDs "Fire" (L1) are blinking (0.4 / 0.4 sec.).
- Output for routing equipment (Fire brigade TX) and outputs type "Routing equipment" are activated.
- Programmable outputs for fire alarm are activated<sup>29</sup>.
- In the FT1020G3 display, a presentation number (zone/address) with a user definable text message (if programmed) will be shown (for the first fire alarm).
- Some additional information is also presented in the FDCIE display e.g. presentation number, text message, etc.

<sup>29</sup> Outputs programmed for General fire alarm and outputs programmed for the activated fire alarm(s).

### One alarm point activating fire alarm.

Example; fire alarm zone 002, address 03 (within zone 002):

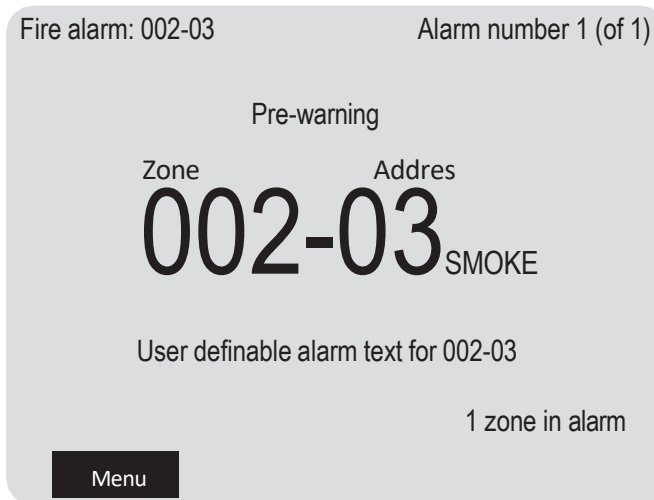

The presentation number is automatically followed by: SMOKE, HEAT, MULTI or MCP depending on the type of alarm point.

### More than one alarm point activating fire alarm.

Example; fire alarm in zone 002, address 03 (within zone 002) and nine other fire alarms (of which the latest alarm is 003-11) in four different zones:

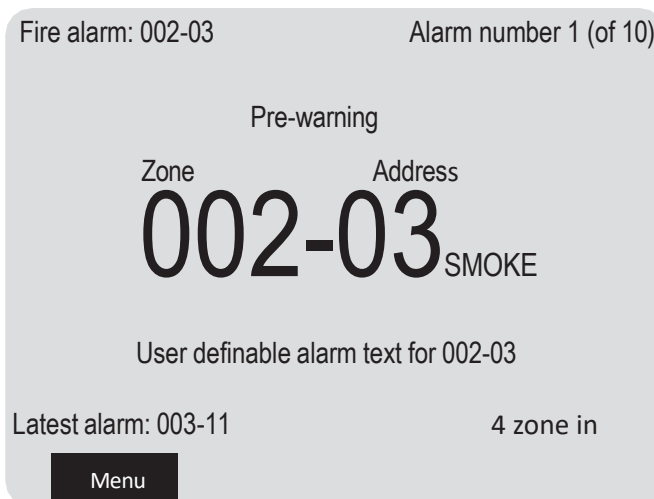

**User definable alarm text**, for each alarm point and zone line input, an individual alarm text can be shown. Each zone has its own individual alarm text (if programmed). Up to 40 alphanumeric characters can be used.

### Additional information

First alarm, Latest alarm, Alarm number and number of zones in alarm.

**LEDs "SEVERAL ALARMS"** blinking (0.4 / 0.4 sec.) indicates that more than one fire alarm is activated. To scroll through the alarm points, use the push button "SEVERAL ALARMS".

**Next zone.** Use the soft key "Next zone" to scroll through the **zones** in alarm.

When scrolling through zones, the first alarm point activated in the next zone will be shown. The "Next zone" button will be available only if there are alarms in more than one zone.

The first alarm will be automatically displayed again, 20 seconds after the latest time the "SEVERAL ALARMS" or "Next zone" buttons where used.

To **reset** fire alarms, see chapter "Alarm reset", page 67.

## 15.2.1 Entering the Menu during Fire Alarm

By pressing the soft key "Menu" during fire alarm, you will get access to the menu system (see 6.2, page 42).

**Note:** Access code is required, in this case, a part of the display's alarm window will be temporarily suppressed to permit the display of the menu system.

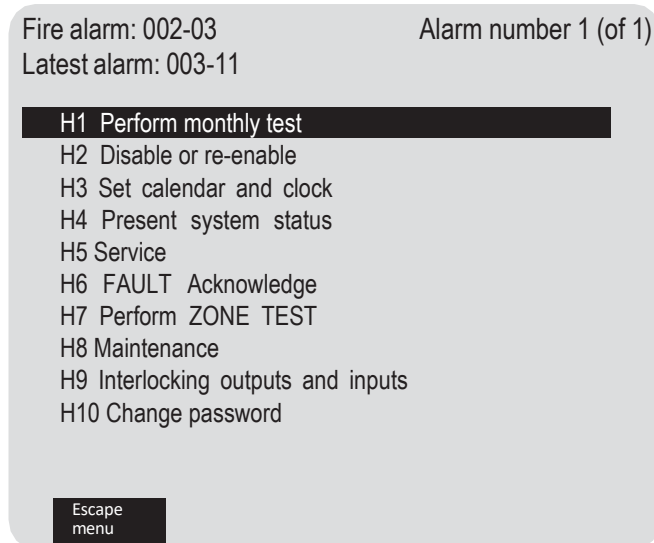

The normal alarm window will be automatically displayed again after the escape from the menu system or 5 minutes after the latest access to the menu system.

The alarm window will also be automatically displayed again if any of the soft keys "Esc menu" or "ESC" is pressed or push button "SEVERAL ALARMS".

## 15.2.2 Test Mode Alarm

Regarding Test mode, see chapter "Perform Monthly Test (H1)", page 111 and chapter "Perform Zone Test (Test mode) (H7)", page 149.

When an alarm point in a zone set in test mode is tested, it is presented in the display as a fire alarm but with the information "Test mode" added.

No outputs will be activated except the fire door outputs. The test mode alarm will automatically reset after approx. 10 seconds.

## 15.3 Heavy Smoke Alarm / Heavy Heat Alarm

An analogue detector (sensor) can activate a heavy smoke / heat alarm for a higher alarm level than the normal fire alarm level, i.e. a normal fire alarm is already activated by a detector activating a heavy smoke / heat alarm, for more details refer to the "Help" in EBLWin.

**Heavy smoke / heat alarm** is a confirmation that the smoke or heat is increasing and can be used for specific actions.

**The following occurs in case of a heavy smoke / heat alarm:**

- Outputs programmed for heavy smoke / heat alarm are activated. General heavy smoke / heat alarm and individual alarm points / zones.
- Each heavy smoke / heat alarm is presented with a "title", i.e. "Heavy smoke" or "Heavy heat" will be added to the normal fire alarm information:

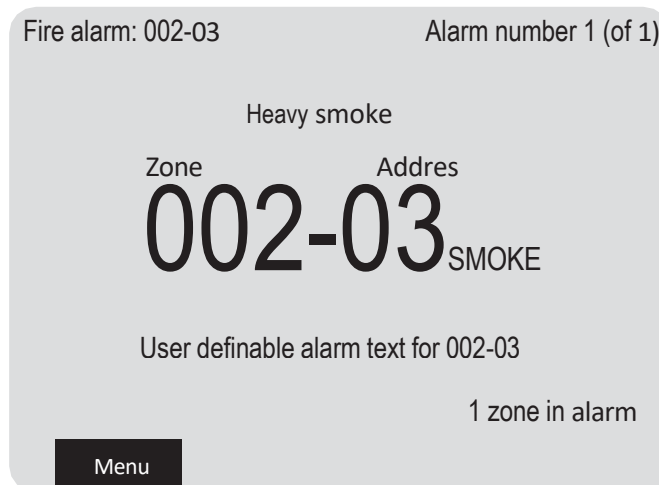

Heavy smoke / heat alarm will be reset when the fire alarm is reset, see chapter "Alarm reset", page 67.

## 15.4 Alert Annunciation Alarm (AA alarm)

When the **AA** function is enabled, indicated by the LED routing equipment "Fire brigade TX delay", the indications, actions, etc. are similar to a normal fire alarm (see above) **except** for the FT1020G3 output for routing equipment (Fire Brigade TX), **will not** be activated directly.

There will also be a "title", i.e. "Alert annunciation" or "Alert annunciation acknowledged" added to the normal fire alarm information.

The **AA** alarm has to be acknowledged within an acknowledgement time and reset within an investigation time, otherwise the output(s) for routing equipment (Fire Brigade TX) will activate. Acknowledgement and reset of the **AA** alarm can be performed when 5054 display unit is configured as alert annunciation or the discontinued 1736 display unit

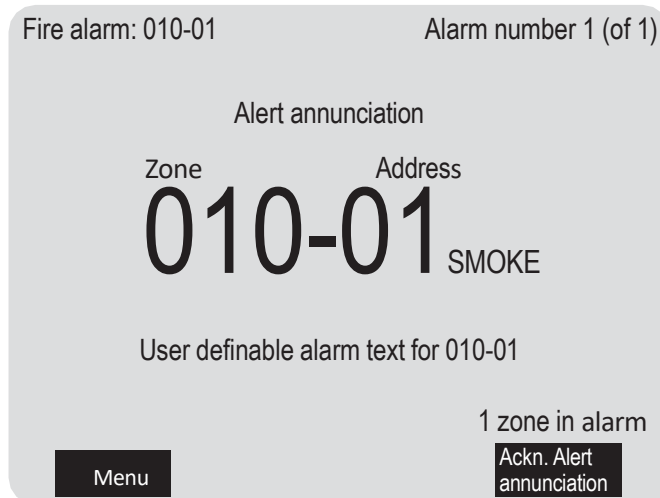

**Note:** The "Ackn. alert annunciation" text is only visible if an AA alarm is activated.

## 15.5 Key Cabinet Alarm

In some European conventions, the fire brigade personnel use a key cabinet to store a key for the building. **This feature is not used in AU or NZ conventions.**

## 15.6 Co-Incidence Alarm (2-Address / -Zone Dependence)

The co-incidence alarm function is programmed via EBLWin for specific alarm points / zones.

When only one **zone** or one **zone / address** (alarm point) is in alarm state, the FDCIE buzzer sounds (0.8 / 5 sec.) and there is a **Co-incidence alarm** presentation in the display.

**Note:** LEDs "Fire" (L1) are not indicating a co-incidence alarm.

The co-incidence alarm will be automatically **Reset** after 5 minutes or via the "Reset" button (P3). See chapter "Alarm reset", page 67.

Example; Co-incidence alarm zone 123, address 45 (within zone 123):

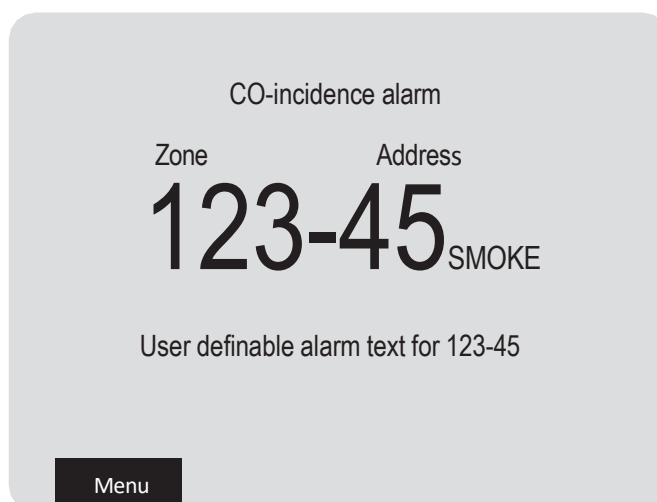

If more than one Co-incidence alarm **not** dependent on each other are activated, the LEDs "SEVERAL ALARMS" (L6) are blinking and the Co-incidence alarms will be automatically scrolled (each 5<sup>th</sup> second).

If **two or more zones** or **alarm points** (zone / addresses) dependent on each other are in alarm status at the same time, normal fire alarm (see above) will be activated in the system.

The co-incidence alarm function can be turned on / off via a time channel.

## 15.7 Delayed Alarm

Delayed alarm is an option that can be enabled via EBLWin for a specific alarm point. Two applications for delayed alarm are shown below.

### 15.7.1 Standard Alarm Delay Applications

In some premises, delayed fire alarm activation from analogue smoke detectors can be used to avoid nuisance alarms. The delay time will be added at the end of the alarm algorithm when a fire alarm normally would have been activated in the FDCIE. This function is not allowed due to the fire brigade requirements.

**Note:** The delayed alarm function for a conventional Zone Line Input e.g. 4461 Input 0 (Z) or zone expansion board 4580 inputs is different. The “Delayed alarm” check box in the Zone Line Input properties is called “AVF”, the general delayed alarm function will not be used and will be replaced by the alarm verification function (AVF).

### 15.7.2 Alarm Delay Facility (ADF)<sup>69</sup>

The alarm delay function in the system properties must be set in normal conditions to the default value if ADF feature is not used.

The Alarm Delay Facility ADF is a defined function specified in AS1670.1:2015 (clause 3.2.3), used to reduce nuisance fire alarm condition by providing a local warning which if not cleared after a defined delay, will escalate to a fire alarm condition. This is used to control the smoke detection activation within SOUs in class 2, 3 and 4 buildings. The function can be utilised to replace the requirement for the wall mounted acknowledgement module (LAAF or AAM).

The ADF feature has been added to 4400I and 4400 in EBLWin **software V3.6** or higher. The sounder base (3379) is activated in case of a smoke detection alarm for adjustable period of 0-300 second to provide local warning. If the smoke signal remains active after the time delay period elapsed, general fire alarm will be generated in the FDCIE. On the contrary, if any heat activation occurs during the delay time, it will override the time delay and triggers the general fire alarm functions in the FDCIE.

If the smoke is cleared from the detector before the end of time delay, the alarm will automatically reset and the system remains in the normal condition.

This feature cannot be used with software version < V3.6.

#### Application Example:

A typical application for the ADF would be a residential accommodation where false alarms may cause a brigade call. A sounder base(s) 3379 is used as a local audible warning, inside the accommodation e.g. apartment, unit, etc. In case of an alarm from a smoke detector inside the unit, 3379 sounder operates and continues to operate for the time delay configured in the system properties (0-300 sec). If the smoke has not been cleared from the smoke detector after the time delay, the control panel will generate a general fire alarm condition. If the smoke clears up within the delay time, the alarm will automatically reset, 3379 will be silenced and the system restores to the normal condition. In application where multi detectors (4400 or 4400I), are used “*Abort delay on heat*” check box has to be selected in detectors properties, so that the control panel will override the time delay and generate general fire alarm upon heat activation.

Several control expressions are available to cover any possible configuration:

- DelayedAlarmZoneAddress (Zone, Address), true when a specific zone / address is in delayed alarm state.
- DelayedAlarmZone (Zone), true when a specific zone or any detector in a specific zone is in delayed alarm state.
- GeneralDelayedAlarm, true when any zone or zone/address is in delayed alarm state.

**Note:** Detail procedures of EBLWin configuration for ADF feature can be found in Analogue Multi Detector with isolator 4400I Technical Datasheet (TDS074).

## 15.8 Local Alarm Acknowledgement (LAA) Facility Control

One or more Local Alarm Acknowledgement Unit (LAAU or discontinued AAM) can be used in the system.

The LAAF is a function requires wall mounted Local Alarm Acknowledgement Unit (LAAU) 4445 or the Brooks discontinued Alarm Acknowledgement Module (AAM). The LAAU is used in residential applications to provide the occupant with a local control facility to control nuisance alarms within the occupancy e.g. cooking fumes, smoking, aerosol spray, steams, etc. and prohibit this nuisance alarm from generating a general fire alarm within the building. It provides the occupant inside the sole occupancy unit with a pre-determined time to acknowledge a nuisance alarm and additional time to investigate the alarm in the active unit.

A complete AAF zone requires an LAAU (AAM), one or more sounder base 3379 and up to 5 analogue smoke detectors (sensors). Each AAF unit configured as an AAF zone.

During the Acknowledgement Period (10-120 sec.), the following information (a list if many) is shown in the FDCIE display:

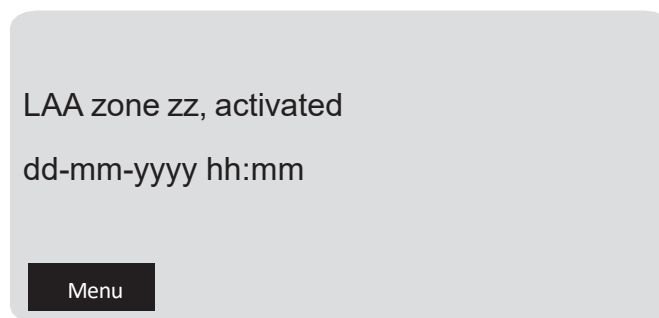

During the Investigation Period (1 - 9 min.), the following information (a list if many) is shown in the FDCIE display:

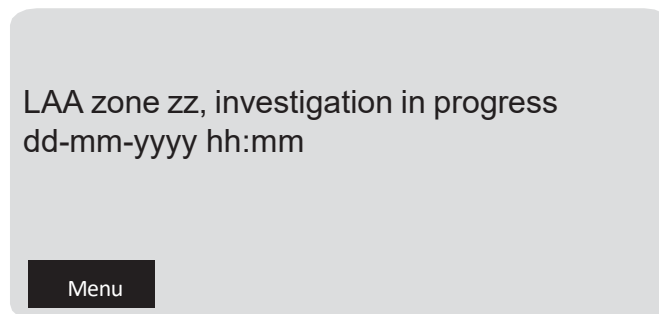

**Note:** The Local Alarm Acknowledgement Unit (4445) is the newer version of the discontinued Alarm Acknowledgement Module (3340). In software  $\geq$  V2.2.0, the Australian AAFC function is moved to the obsoleted units and replaced by the LAA. The function of AAFC and LAA are identical, only the wall control unit is different.

## 15.9 Quiet Alarm

Quiet alarm is an alarm type that can be programmed via EBLWin for analogue smoke detectors. The quiet alarm is self-resetting alarm (non-latching), it is only displayed on the LCD and is not activating general alarm functions.

This feature is used in AS1668 supply air fan / stair pressurization fan control applications.

In AS1668 supply air fan applications, the type "Quiet alarm" is used in EBLWin to set the duct detector to be non-latching and resets automatically after the post timing<sup>30</sup> is completed, post time can be configured in EBLWin using a specific time signal period. In this application, the I/O module 4461 must be selected as "4461 for fan".

<sup>30</sup> When the smoke clears up from the smoke chamber, the detector resets after predetermined time (normally 60 sec.)

In residential applications utilising manual control, an analogue smoke detector set to type "Quiet alarm" is used in conjunction with the sounder base 3379 and LAAU 4445 as a local warning inside the sole occupancy unit.

**Quiet alarm Indications and actions:**

- Detector LEDs are turned on (also a connected RIL).
- LEDs "Fire" are blinking (0.4 / 0.4 sec.).
- The buzzer sounds (0.8 / 5 sec.),
- A Quiet alarm presentation (incl. a title "Quiet alarm") in the display.

Programmable outputs for quiet alarm are required e.g. 4461 outputs controlling fan operation i.e. any output with a control expression containing the trigger conditions "Quiet Alarm Zone" or "Quiet Alarm Zone Address" will display as shown below:



Quiet Alarms are automatically reset, non-brigade call alarm and do not activate general alarm output, see "Quiet Alarm Reset" page 69.

## 15.10 Acknowledged and Isolated Alarm

**Note:** Acknowledged or Isolated alarm is a fire alarm function used only in New Zealand convention.

### 15.10.1 Acknowledged Alarm

A fire alarm presented in the display can be acknowledged by pressing the soft key "Acknowledge".

Acknowledged alarms are indicated in the display by "Acknowledged alarm" in the same position as "Heavy smoke" / "Heavy heat". This indication is the only difference between a normal fire alarm and an acknowledged alarm.

Acknowledged alarms have to be reset same as normal fire alarms.

### 15.10.2 Isolated Alarm

A normal fire alarm or an acknowledged alarm presented in the display can be isolated as follows:

When the "New Zealand FB Silence switch" (outside switch) is restored i.e. from the activated to non-activated), any fire alarm and acknowledged alarm will be isolated (disabled).

Isolated alarms are indicated in the display by "Isolated alarm" in the same position as "Heavy smoke" / "Heavy heat".

Isolated alarms do not activate any control outputs, output for routing equipment (Fire brigade TX), FT1020G3 buzzer and do not activate the LEDs "Fire" (L1) in the FDCIE

Isolated alarms have to be reset same as normal fire alarms.

Isolated alarms can be re-enabled via menu H2/B1 before they can activate a new fire alarm again.

## 15.11 Alarm Source

An alarm point can activate a fire alarm based on detection of **smoke**, **heat**, or **multi**. A **Manual call point** can be used to manually activate a fire alarm.

Each fire alarm is presented with a "title", which means that the alarm source "**Smoke**", "**Heat**", "**Multi**", or "**MCP**" will be added to the normal fire alarm information:

Alarm sources can be used to trigger control expressions, for more details, refer to the planning instructions in EBLWin "Help".

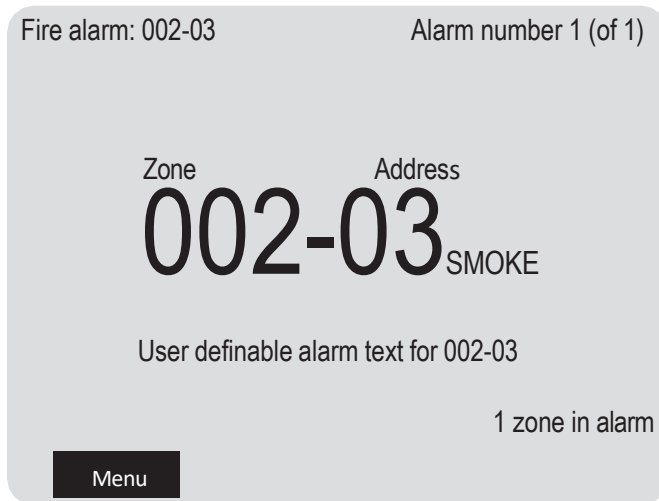

## 16 Alarm Reset

**Note:** The “RESET” button will not reset an active alarm if the “SILENCE ALARM” button is not pressed first.

### 16.1 Pre-warning Reset

Pre-warnings are non-latching alarms i.e. automatically reset when the alarm point / zone is no longer above pre-warning level. Outputs activated by pre-warning will be de-activated.

### 16.2 Fire Alarm Reset

In the New Zealand convention, fire alarms are displayed on the LCD as normal fire alarm “Alarm”, acknowledged alarm is shown as “Acknowledged” and isolated alarm is shown as “Isolated”.

**Note:** The detectors having activated fire alarm should, after reset, be inspected, tested and replaced when required.

The default setting “All” must be used.

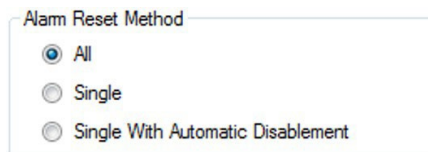

#### 16.2.1 All (Default)

All activated fire alarms (alarm points / zones) will be reset by pressing "RESET" once but must be preceded by “SILENCE ALARM” button activation (this is in accordance with the fire brigade standard AS4428.3).

The push button has to be pressed for minimum 0.5 sec.

When all fire alarms are reset, LEDs "FIRE" and "SEVERAL ALARMS" are turned off. If other conditions exist (e.g. a fault condition), the corresponding information will be displayed on the LCD. For the priority order see chapter "The information area priority order", page 21.

All outputs (for fire alarm) are reset, i.e. de-activated.

**Note:** When "Single" or "Single with automatic disablement" is used, all alarms can be reset by pressing "RESET" and approx. 0.1 sec. later also press "Enter" and hold them pressed for > 0.5 sec. **Both alternatives must not be used in the Australian or NZ conventions.**

#### 16.2.2 Single

Each fire alarm (alarm point / zone) has to be reset individually.

Press "RESET" to reset the fire alarm currently shown in the middle of the display with large font.

The push button has to be pressed for min. 0.5 sec.

Output(s) programmed for that fire alarm (alarm point / zone) will be reset, i.e. de-activated.

If more than one fire alarm is activated (i.e. LEDs "SEVERAL ALARMS" (L6) are lit) the next fire alarm in the queue will be shown in the middle of the display. It has to be reset the same way as the first one.

**When all fire alarms are reset**, LEDs "FIRE" and "SEVERAL ALARMS" are turned off. If any other conditions exist e.g. fault condition, the corresponding information will be shown (fault message), for priority order see section 3.4.2.3, page 21.

All outputs (for fire alarm) are reset, i.e. de-activated.

### 16.2.3 Single with Automatic Disablement

Similar to "Single reset" but includes the encapsulation function:

Normally when an alarm point or zone having activated fire alarm is reset whilst the alarm point or zone still in alarm status, it will activate a new fire alarm within 20 seconds.

When "Single with automatic disablement" option is selected in EBLWin, if a reset is performed whilst an alarm point or zone still in alarm condition, the alarm will reset but the alarm point or zone will also be disabled, i.e. it will not activate a new fire alarm.

It has to be re-enabled via menu H2/B1 before it can activate a new fire alarm.

LED Fault / Disablements "General disablements" (L10) is indicating one or more disablements in the system.

When "All" or "Single" reset is used, "automatic disablement" (encapsulation function) can be used by pressing "Reset" and approx. 0.1 sec. later also press "SEVERAL ALARMS" and hold them pressed for > 0.5 sec.

The alarm point or the whole zone (conventional) currently shown in the middle of display with large fonts will be reset and disabled.

**Note:** The single reset with encapsulated function is not used in the Australian convention as the function is now added to the "Disable" function in the fire brigade panel as required now in FT1020G3. Refer to Chapter 13 "DISABLE" Button page 55.

### 16.3 Test Mode Alarm

Test mode alarm is automatically reset after approx. 10 seconds.

### 16.4 Acknowledged and Isolated Alarm (for only NZ) Reset

Acknowledged alarms "Acknowledged" or isolated alarm "Isolated" have to be reset same as normal fire alarms "Alarm".

### 16.5 Heavy Smoke / Heat Alarm Reset

If a heavy smoke / heat alarm has been activated, it will reset at the same time as the corresponding fire alarm is reset. Also, the output(s) will be reset i.e. de-activated.

### 16.6 Alert Annunciation Alarm Reset

Regarding the function, see chapter "Alert Annunciation alarm (AA alarm)" page 61, EBLWin Help (Planning instructions), chapter "Alert annunciation".

Reset of the **AA** alarm(s) can be performed via push button "Reset" on a display unit 5054 configured as alert annunciation or in the FDCIE.

**Note:** Reset via an AA unit is only possible during the investigation time and only if the alarm is configured as an AA alarm (not normal fire alarms). If more than one AA alarm is activated, they will all be reset at the same time.

### 16.7 Co-incident Alarm Reset

A Co-incident alarm can be manually reset with the "RESET" button on the FDCIE front or automatically resets after 5 minutes (i.e. if the alarm point / zone is no longer in alarm status). See also chapter "Co-incident alarm (2-address / -zone dependence)", page 62.

### 16.8 Delayed Alarm Reset

The Delayed alarm will be automatically reset if the alarm point during the delay time countdown is no longer in alarm state or when a normal fire alarm is activated (i.e. when the delay time has run out).

## **16.9 Alarm Delay Facility (ADF) Reset**

The ADF alarm will be automatically reset if the smoke clears during acknowledgement or investigation time delay i.e. the device is no longer in alarm condition when the delay time elapsed. Refer to section 15.7.2 page 63.

## **16.10 Local Alarm Acknowledgement (LAA) Reset**

The indication in the Control Unit display, during the Acknowledgement Period (10-120 sec.) and the Investigation Period (1-9 min.) respectively, will automatically clear when:

- The AA process is terminated because no detector in the LAA zone exceeds the fire alarm level.
- The AA process ends up with a fire alarm, which has higher priority.

## **16.11 Quiet Alarm Reset**

Quiet alarms are non-latching, i.e. they will be automatically reset when the alarm point / zone is no longer in alarm state. Outputs activated by quiet alarm will be de-activated (in some cases after a programmable delay time).

## 17 Fault

All faults are delayed in order to avoid generating unnecessarily faults but still within 60 second as required by AS7240.2. Some units may also have an internal delay time, which makes the delay time even longer.

In case of a fault condition, the following will occur in the FDCIE:

- The buzzer in FT1020G3 sounds continuously (steady).
- The fault relay output for routing equipment (Fault TX) is de-activated (fault relay is normally energised).
- Programmable output(s) for general fault is activated and output(s) for general charger fault might be activated.
- LED Routing equipment "Fault TX activated" is illuminating.
- LED Fault / Disablements "General fault" is illuminating.
- LEDs Fault / Disablements "Alarm devices", "System fault" and/or Fault / Disablements "Fire brigade TX" may also illuminate.
- A fault message including date, time and status is displayed on the FDCIE display. If the fault is generated by an alarm point or zone, the user definable alarm text will be shown.

Example; fault message:

```

FAULT: No reply zone: xxx address: xx
technical number xxxxxx

User definable alarm text

dd-mm-yyyy hh:mm           /Serviced

Number of faults in

Menu
  
```

- In the FDCIE display up to three fault messages can be shown simultaneously. In the display, down to the left, the number of faults is displayed.
- If a fault has been corrected (Serviced) before it has been acknowledged, the status information is "Serviced", see above. In EBLWin, if the fault is set to be non-latching in the system properties, the "Serviced" fault will disappear however, the fault will be saved in the even log.
- Fire alarm presentation has higher priority than the fault messages. However, during fire alarm presentation the faults can be shown via the menu system (fault acknowledge H6), see "Entering the Menus during Fire Alarm" page 60.

Faults have to be acknowledged, this is done via menu H6 (see page 148). This menu is a list of all faults in the system:

- Not corrected / serviced and not acknowledged fault
- Not corrected / serviced but acknowledged fault (acknowledged)
- Corrected / serviced but not acknowledged fault (serviced)

If a fault cannot be corrected, contact service personnel / engineer immediately.

The faults are normally latched, but can be set via EBLWin to be "not latched". This will make the fault disappear from the list when serviced but not acknowledged.

The fault list will be shown when the user is logged out of the menu, displays all faults, even acknowledged faults.

**Note:** As a reminder, faults (and disablements) are indicated by a 2-sec. beep when an open FDCIE door is being closed.

## 17.1 Fault Messages

The section follows a list of all possible fault messages, in alphabetical order. There is also an explanation to each fault.

Checksum fault in downloaded data.  
Control unit will now restart

---

A fault in the downloaded Site Specific Data (SSD). After restart a new fault will be generated:  
FAULT: Site Specific Data (SSD), Control Unit xx.  
A new SSD download will probably correct the problem.

FAULT: 24V for AAU xx, (Primary channel), CU xx  
FAULT: 24V for FBP xx, (Primary channel), CU xx  
FAULT: 24V for EPU xx, (Primary channel), CU xx  
FAULT: 24V for GCP xx, (Primary channel), CU xx

---

The AAU/FBP/EPU/GCP unit xx, connected to control unit no. xx, has no power on its 24V primary input. Check cables/ connections/ fuses etc.

FAULT: 24V for AAU xx, (Secondary channel), CU xx  
FAULT: 24V for FBP xx, (Secondary channel), CU xx  
FAULT: 24V for EPU xx, (Secondary channel), CU xx  
FAULT: 24V for GCP xx, (Secondary channel), CU xx

---

The AAU/FBP/EPU/GCP unit xx, connected to control unit no. xx, has no 24V power on its secondary input. Check cables/ connections/ fuses etc.

FAULT: 24V for Display Unit (Fxx), CU xx

---

xx = Fuse number(18 or 19), xx = 00-29.  
Check fuse F18 or F19 on the main board in control unit no. xx.  
Fuse: T1.6AH 250V.

**Note:** *These 24V outputs, together with the 24V output for routing equipment, are also protected by an auto-reset- table fuse PTC2 (max 3.15A). If this fault message occurs and the fuse is not blown, check the 24V outputs for combined overload.*

FAULT: 24V for expansion board (Auto-resettable), CU xx

---

xx = 00-29.

The auto-resettable fuses PTC4 and PTC12 (total max 1A) has been activated. Check for overload on the expansion board's outputs.  
To reset the PTC, remove the load and wait 5 min to allow for the PTC to cool down before re-connecting the load.

FAULT: 24V for external equipment output 1 (F9), CU xx

---

xx = 00-29.  
Check fuse F9 on the main board in control unit no. xx.  
Fuse: T1.6AH 250V.

**Note:** *This 24V output, together with the other 24V outputs for external equipment (2-4), are also protected by an auto-resettable fuse PTC1 (max 3.15A). If this fault message occurs and the fuse is not blown, check all the 24V outputs for combined overload.*

FAULT: 24V for external equipment output 2,3,4 (F10), CU xx

xx = 00-29.

Check fuse F10 on the main board in control unit no. xx.

Fuse: T3.15AH 250V.

**Note:** *These 24V outputs, together with the other 24V output for external equipment (1), are also protected by an auto-resettable fuse PTC1 (max 3.15A). If this fault message occurs and the fuse is not blown, check all the 24V outputs for combined overload.*

FAULT: 24V for MMI (auto-resettable), CU xx

xx = 00-29.

The auto-resettable fuses PTC9 and PTC10 (total max 1A) has been activated. Check for overload or damage on the MMI board. To reset the PTC, disconnect the MMI board and wait 5 min to let the PTC cool down before re-connecting the MMI board

FAULT: 24V for routing equipment (F8), CU xx

xx = 00-29.

Check fuse F8 on the main board in control unit no. xx.

Fuse: T500mAH 250V.

**Note:** *This 24V output, together with the 24V outputs for display units, is also protected by an auto-resettable fuse PTC2 (max 3.15A). If this fault message occurs and the fuse is not blown, check all the 24V outputs for combined overload.*

FAULT: 24V for Gateway (auto-resettable), CU xx

xx = 00-29.

The auto-resettable fuse PTC11 (max 500mA) has been activated.

Check for overload or damage on the Gateway.

To reset the PTC, disconnect the Gateway and wait 5 min to let the PTC cool down before re-connecting the Gateway.

FAULT: 24V out, output unit xxxxxx

Valid for the external power supply 4466 connected on the COM loop.  
The output might be turned off or the current limit is exceeded.

FAULT: Alert annunciation unit xx,  
Channel x, Control Unit xx

5054 (set as Alert Annunciation Unit - AAU.)

The AAU unit xx, connected to channel x, connected to Control Unit no. xx, is programmed as another type in the SSD or a fault in the unit.

FAULT: Alert annunciation unit xx,  
Control Unit xx

5054 (set as Alert Annunciation Unit - AAU.)

The AAU unit xx, connected to Control Unit no. xx, is programmed as another type in the SSD or a fault in the unit.

<p>FAULT: Battery not connected, Control Unit xx</p>
<ul style="list-style-type: none"> <li>• Battery voltage is below 18.9 V.</li> <li>• Batteries (2 x 12 V) are missing or not connected correctly.</li> <li>• Fuse F2 on the Main board is blown.</li> <li>• Other battery fuse is blown (in-line fuse between batteries).</li> </ul> <p>This check is performed every approx. 1 minute the fault is generated within 60 sec. Fuse: F6.3AH 250V (5x20 mm ceramic).</p>

<p>FAULT: Battery, technical number xxxxxx</p>
<p>The charging function in the external power supply 4466 connected on the COM loop is not functioning.</p> <ul style="list-style-type: none"> <li>• Batteries (2 x 12 V) are missing or not connected correctly.</li> <li>• The PCB is faulty and has to be replaced.</li> </ul>

<p>FAULT: Battery zone xxx address xx, Technical number xxxxxx</p>
<p>Valid for the wireless detectors 4611. The battery voltage is &lt; 2.8 V, batteries have to be replaced.</p>

<p>FAULT: Charger, Control Unit xx</p>
<p>The battery charging function is not functioning. The main board may have to be replaced.</p>

<p>FAULT: Charging external power supply, Control Unit xx</p>
<p>The fault is to be found in the external power supply equipment, which has a charging fault output connected to a programmable input in Control Unit no. xx.</p>

<p>FAULT: Charging output unit xxxxxx</p>
<p>The fault is detected if an external power supply unit 4466 connected. Charging is stopped due to too high output current.</p>

<p>FAULT: Checksum MMI program, Control Unit xx</p>
<p>A fault in the Control Unit xx MMI board software. LED "System fault" is turned on. Call for service personnel immediately. Software/firmware download may correct the fault otherwise the MMI board may need to be replaced.</p>

<p>FAULT: Checksum system program, Control Unit xx</p>
<p>A fault in the Control Unit xx Main board software. LED "System fault" is turned on. Call for service personnel immediately. Software/ firmware download may correct the fault otherwise replace the MMI board.</p>

**FAULT: Control unit xx has no contact with Control Unit xx, network x**

network x = network 0 or network 1

**Network 0:** In a redundant network, the communication is normally on Network 0 only.

**Network 1:** In a redundant network, Network 1 is normally in a supervised quiescent state until a fault is generated (cut-off or short circuit) on Network 0.

- Check the TLON network / EBL Ring network cables / connections. (Also for mixed Network 0 and Network 1 cables.)
- Faulty TLON connection board 5090 / EBL Ring network board 5040.
- The Control Unit has no power.
- Can be shown in conjunction with new S/W download.

**FAULT: Cut-off tech addr nnn <-> nnn [sup-loop x], loop x, CU xx**

This fault is indicating a cut-off (break) on **COM** loop x or the **COM** loop voltage is too low at the end of the loop.

Tech add nnn <-> nnn describes between which Short Circuit Isolators the cut-off is located.

n = Technical address of the unit with short circuit isolator A, B, 0, 1, 2, 3, 4, 5, 6 .....128. A & B are the built-in isolators in the FT1020G3 A-direction and B-direction respectively.

If a single break occurs on the loop, other fault messages will display.

If there are several breaks on the loop the message shows the last isolator before the break in the A-direction (incl. the following isolator). There will also be a "FAULT: No reply ....." message for each unit that FT1020G3 cannot find and "FAULT: Multiple faults ...".

**NOTE:** Each 10th minute, a new attempt is made to communicate in one direction only. When all breaks are repaired (corrected), communication automatically returns to communicate in one direction only.

**FAULT: Detector removed zone xxx address xx**

A wireless smoke detector 4611 has been removed from its base.

**FAULT: Display units mixed on channels (Primary/Secondary), CU xx**

The primary and secondary channels to the display units connected in control unit xx have been mixed. Check cables and connections.

**FAULT: Earth fault (minus), Control Unit xx**

**FAULT: Earth fault (plus), Control Unit xx**

Earth fault is detected in control unit no. xx.

+24 V to earth is normally 11.5 V. 0 V to earth is normally 12.5 V.

- Voltage to earth < 3.0 V = Earth fault (minus)
- Voltage to earth > 21.9 V = Earth fault (plus)

Check all cables (for damage, etc.). The function of the Control Unit cannot be guaranteed. Call for service technician.

**Note:** When the earth fault is located on a COM-loop it can be difficult to measure with a multi meter due to the fact that SA and SB changes polarity during COM loop communication. However, the FDCIE makes measurements at specific timings when the polarity of SA and SB is known. In case of an earth fault on a COM-loop it will be displayed as follows:

- Earth fault on the SA line will be displayed as Earth fault (minus)
  - Earth fault on the SB line will be displayed as Earth fault (plus)
- Disconnect the loops one by one to find out where the earth fault is.

FAULT: Earth fault,  
technical number xxxxxx

Check all cables (for damage, etc.) connected to the unit.

FAULT: Expansion board x, Control Unit xx

This is valid for the exp. boards 4580 & 4581, i.e. expansion board no. x, mounted in the Control Unit no. xx.  
There is an internal fault on the board, replace the board.

FAULT: Expansion board x, loop x,  
Control Unit xx

This is valid for the I/O Matrix board (4582) no. x, connected on COM loop x (0-3) in the Control Unit no. xx.  
There is some internal fault on the board, replace the board.  
**Note:** In 19" rack systems, the 4582 circuit is incorporated in the new fan / damper (1206/1211) and zone (1205) modules, in this case, replace the module.

FAULT: External fuses,  
Control Unit xx

The fault is to be found in the external power supply equipment, which has a fuse fault output connected to a programmable input in Control Unit no. xx.

FAULT: External power supply,  
Control Unit xx

The fault is to be found in the external power supply equipment, which has a fault output connected to a programmable input in CU xx.

FAULT: External presentation unit xx,  
Control Unit xx

5054 (set as EPU)  
The EPU xx, connected to Control Unit no. xx, is programmed as another type in the SSD or a fault in the unit.  
**Note:** The EPU may be called Remote Display Unit (RDU) or Mimic

FAULT: Extinguishing system,  
Control Unit xx

= Fire Protection Activated – AS4428.3  
Fault in the extinguishing system which has a fault output connected to a programmable supervised input in FT1020G3 system, in Control Unit no. xx. Also check the input connections.  
There will also be an additional information text in the display: "Extinguishing fault".

FAULT: Factory settings,  
Control Unit xx

The factory settings have been "changed", in Control Unit no. xx, e.g. due to some external disturbance. Call Brooks engineering or replace the main board.

**FAULT: Fan, technical number xxxxxx**

The LED "Fault" is lit on a fan control module connected to Control Unit xx. Fan no. xx has been triggered but the corresponding I/O unit 3361 / 4461 input has not been activated within the programmed time. Check CT or pressure switch in MSSB and the cables/connections. The fan phase fault input is activated. Check Cables / connections.

**Note:** *This fault is "non-latching" irrespective of all other faults are being "latched".*

**FAULT: Fault warning routing equipment, control unit xx**

The fault is to be found in the Fault warning routing equipment. Not used in the Australian convention.

**FAULT: FB Silence switch, Control Unit xx**

Only valid in the New Zealand convention. New Zealand FB Silence Alarms Bulgin key (outside switch) is turned on, in Control Unit no. xx, i.e. from not activated to activated state.

**FAULT: Fire brigade panel xx, Control Unit xx**

If 5054 is used as External Fire Brigade Panel (FBP) The ext. FBP xx, connected to Control Unit no. xx, is programmed as another type in the SSD or a fault in the unit.

**Note:** *Currently not available and not compliant with AS4428.3.*

**FAULT: Fire brigade panel xx, channel x, CU xx**

If 5054 is used as External Fire Brigade Panel (FBP) The ext. FBP xx, connected to Channel x, Control Unit no. xx, is programmed as another type in the SSD or a fault in the unit.

**Note:** *Currently not available and not compliant with AS4428.3.*

**FAULT: Fuse output x, Technical number xxxxxx**

Blown fuse 0, 1 or 2 on the 4464 board or in power supply 4466. Replace blown fuse.

**Note:** *4464 & 4466 are not currently available.*

**FAULT: Fuse supervised output x (auto-resettable), CU xx**

x = 0-3, xx = 00-29.

The auto-resettable fuse PTC7 (for output 0), PTC8 (for output 1), PTC5 (for output 2) or PTC6 (for output 3) (max 500mA) has been activated. Check for overload on the equipment connected to the output. To reset the PTC, disconnect the connected equipment and wait 5 min to let the PTC cool down before re-connecting the equipment.

**FAULT: General control panel xx, CU xx**

If 5054 is used as a General control panel (GCP)

The GCP xx, connected to control unit no. xx, is programmed as another type in the SSD or a fault in the unit.

**FAULT: High current [sub-loop x] loop x, Control Unit xx**

When starting up the control unit or when the COM-loop is reconnected, the loop current in normal condition is measured and stored.

**Main board 5012 and a SUB-loop connected to 4585:**

This fault will be generated for a measured current higher than the stored value plus 50mA. (One example: 75 mA (stored) + 50mA = 125 mA = fault limit.)

**Note:** *This fault is not checked in alarm condition. The reason could be not "full" short circuit on the COM loop but very close to short circuit, e.g. due to moisture / corrosion / bad contact. Check connections etc.*

**FAULT: High current consumption, Control Unit xx**

The Control Unit current consumption is > 2.8A (> 6.3A in alarm state), in this case, the battery charging is turned off and remains off until the current consumption is decreased to < 2.8A (<6.3 A) again.

**FAULT: High resistance [sub-loop x ] loop x , CU xx**

The loop resistance measured by the control unit / 4585 board is too high for the current consumptions. Check cables/ connections etc. The measure value can be seen in menu H5/A6

**FAULT: Interlocking input AAA-PP**

An interlocking input is not activated within the time set for fault activation (5-255 seconds). The time is counted from the activation of the output in the interlocking combination, area AAA / point PP.

**FAULT: Internal short circuit COM loop x, CU xx**

Short-circuit on the connection (ribbon cable) to or between the Expansion Boards (458x) in the Control Unit xx (FT1020G3).

**FAULT: Cables mixed [sub-loop x], loop x, CU xx**

The two wires L (SA) and C (SB) for COM-loop no. x (0-3), in Control Unit no. xx, have been mixed (alternated). Check / correct the wire connections.

**FAULT: Loop unit, Technical number xxxxxx**

The Brooks customized unit is not functioning, i.e. the unit is faulty. The unit has to be replaced. This is for **1200** series of panel display or field modules.

**FAULT: Loop unit zone: xxx address: xx  
technical number xxxxxx**

The unit is not working properly, i.e. the unit may be faulty. Replace the unit.

**FAULT: Loop unit zone: xxx address: xx and zone: yyy address: yy  
technical number xxxxxx**

The unit (not a detector) is not working properly, i.e. the unit may be faulty. Replace the unit (not used in AU convention).

**FAULT: Low battery capacity, Control Unit xx**

Battery (in Control Unit no. xx) internal resistance > 0.5  $\Omega$ .

The "Resistance in battery circuit" value is shown in menu H5/A4

- The battery might be too old.
- Battery cables are long and the conductor is less than 2.5mm<sup>2</sup>
- Check / adjust the power supply voltage (24 V<sub>DC</sub>).
- Check the charging voltage over the battery respectively (13.5-13.8 depending on the actual charging step).
- Check the voltage over a disconnected battery (fully charged > 13 V).
- In the New Zealand convention only: The battery charging is turned off 60 minutes every 24th hour to perform auto battery test. A battery voltage < 24.4 V during these 60 minutes will generate a fault.

If a fault is generated it will automatically be Serviced after these 60 minutes.

The battery should normally be replaced in the due time.

**Note:** The 5012 continuously monitors the batteries and generates battery fault within 60 seconds.

**FAULT: Low battery capacity, Technical number xxxxxx**

Battery in external power supply 4466 unit no. xxxxxx internal resistance > 0.7  $\Omega$ .

- The battery might be too old.
- Check / adjust the power supply voltage (24 V<sub>DC</sub>).
- Check the charging voltage over the battery (13.5-13.8 depending on the actual charging step).
- Check the voltage over a disconnected battery (fully charged > 13 V).

The battery should normally be replaced in the due time.

**NOTE:** The battery check is performed every 60 sec, i.e. the fault status will be "corrected" within 60 sec..

**FAULT: Low performance on primary network, CU xx**

Control unit xx has detected several bit faults and/ or low signal strength on the incoming primary network. Check cables, connections, etc.

**FAULT: Low performance on secondary network, CU xx**

Control unit xx has detected several bit faults and/ or low signal strength on the incoming secondary network. Check cables, connections, etc.

**FAULT: Low voltage, Control Unit xx**

System voltage < 21.0 V<sub>DC</sub>, in Control Unit no. xx. Check the power supply output voltage, it must be 24 V<sub>DC</sub>. Replace power supply LS 150-24 if required.

**Note:** A Control Unit powered by only the battery back-up will shut down at a battery voltage of 20.6 V, in order to avoid damaging the batteries. When this fault is detected, the log is automatically saved to flash, in order to keep the log intact after a power failure.

**FAULT: Low voltage, technical number xxxxxx**

System voltage < 21 V<sub>DC</sub> in the external power supply unit 4466. Check the power supply output voltage, which must be 24 V<sub>DC</sub>. Replace power supply if required.

**FAULT: Mains, Control Unit xx**

The fault is detected within 1-300 minutes after:

- Loss of mains, i.e. no 230 VAC
- Blown mains fuse.
- Blown fuse F1 on main board. Fuse **T6.3A** H 250V (5x20 mm ceramic).

When this fault is detected, the log is automatically saved to flash, in order to keep the log intact after a power failure.

**FAULT: Mains, external power supply, Control Unit xx**

This is valid for external power supply equipment, which has a fault output connected to a programmable input in the FT1020G3 system. The fault is detected within 1-300 minutes after the input is activated.

- Loss of mains, i.e. no 230 V AC to the ext. power supply equipment.
- Blown mains fuse.

Check the programmable input

**FAULT: Mains, technical number xxxxxx**

**3366 / 3364**

This is valid for the external power supply unit 3366AU and addressable 2 voltage outputs unit 3364, connected on the COM loop. The fault is detected within 1-300 minutes after:

- Loss of mains, i.e. no 230 VAC to the **3366** unit.
- Blown mains fuse.
- Fuse F1 blown on the 3366 unit (J7:4).
- 3364 unit:
  - Terminal no. 8 (Mains OK) not connected to the 3366 unit (J7:4) or 0 V.
  - "No mains signal" from the 3366 unit.

**4466**

This is valid for the external power supply unit 4466 connected on the COM loop. The fault is activated after 1-300 minutes after:

- Loss of mains, i.e. no 230 V AC to the 4466 unit.
- Blown mains fuse.

- Fuse F1 blown on the 4466 unit's charger board (Fuse T5AH250 V, 5x20 mm).

The time delay of this fault activation is programmable via EBLWin. Maximum 90 minutes is allowed. Default value is dependent on the convention.

FAULT: Multiple faults, [sub-loop x], loop x, Control Unit xx

Break (cut-off) / short-circuit in more than one segment on the COM loop, in Control Unit no. xx.

FAULT: Network board (Network 0), Control Unit xx

FAULT: Network board (Network 1), Control Unit xx

NO communication/ connection with the network board. The board for Network 0 or 1 in control unit no. xx has to be replaced. Check the network board type. The type should be the same as programmed via EBLWin.

FAULT: Network cables mixed, Control Unit xx

In a redundant Network, Network 0 cables and Network 1 cables are mixed. Check the network installation / connections.

FAULT: No connection with MMI board, Control Unit xx

This fault message cannot be shown in the Control Unit's display, only via EBLWin, via Gateway and in other Control Units in the system. Fault in the MMI board software or the MMI board. Check the cable between the boards. Call for service technician immediately.

FAULT: No reply, AAU xx, (Primary channel) CU xx

FAULT: No reply, EPU xx, (Primary channel) CU xx

FAULT: No reply, FBP xx, (Primary channel) CU xx

FAULT: No reply, GCP xx, (Primary channel) CU xx

- Alert Annunciation Unit
- External Presentation Unit
- External Fire Brigade Panel
- General Control Panel

The contact with the unit is interrupted. Check cables, all connections, etc on the primary channel. Is correct/ complete SSD downloaded (via EBLWin)? Check the address and SW mode settings.

FAULT: No reply, AAU xx, (Secondary channel) CU xx

FAULT: No reply, EPU xx, (Secondary channel) CU xx

FAULT: No reply, FBP xx, (Secondary channel) CU xx

FAULT: No reply, GCP xx, (Secondary channel) CU xx

- Alert Annunciation Unit
- External Presentation Unit
- External Fire Brigade Panel
- General Control Panel

The contact with the unit is interrupted. Check the cable, all connections, etc on the Secondary channel. Is correct/ complete SSD downloaded (via EBLWin)? Check the address and SW mode settings.

**FAULT: No reply, Expansion Board x, Control Unit xx**

Valid for the 8 zones exp. board 4580 and the 8 relays exp. board 4581, mounted in the Control Unit no. xx.

FT1020G3 cannot communicate with the board. Check / change the address. Check the cables / connections.

**FAULT: No reply, Expansion Board x, loop x, Control Unit xx**

This is valid for the I/O Matrix circuit (4582) no. x (1205, 1206 & 1211, connected on COM loop x in the Control Unit no. xx.

- Check the board's address, i.e. the I/O Matrix board no. (Jumpers JP1, JP2 and JP3 on the board).
- Check if the board is disconnected from the loop.

**Note:** In 19" rack systems, the 4582 circuit is integrated in the new fan / damper (1206/1211) and zone (1205) modules

**FAULT: No reply, alert annunciation unit xx, channel x, Control Unit xx**

**FAULT: No reply, external presentation unit xx, channel x, Control Unit xx**

**FAULT: No reply, fire brigade panel xx, channel x, Control Unit xx**

**FAULT: No reply, alert General Control Panel xx, channel x, Control Unit xx**

- Alert Annunciation Unit
- External Presentation Unit
- External Fire Brigade Panel
- General Control Panel

The contact with the unit is interrupted. Check the cable, all connections, etc. Is correct / complete SSD downloaded (via EBLWin)? Check the address and SW mode settings.

**FAULT: No reply Loop unit xxxxxx**

The unit (e.g. a customized unit – 1200 series modules), cannot be found by the Control Unit.

- Check the unit's COM loop address (with the programming tool 4414E).
- Check the downloaded Site Specific Data (SSD).
- The unit might be faulty.
- The unit might be removed from the COM loop.
- There might be a double break or short-circuit on the COM loop.

**FAULT: No reply zone: xxx address: xx technical number xxxxxx**

The unit cannot be found by the Control Unit.

- Check the unit's COM loop address (with the programming tool 4414E).
- Check the downloaded Site Specific Data (SSD).
- The unit might be faulty.
- The detector may be removed from its base.
- There may be a double break or short circuit on the COM loop.
- Valid for a wireless smoke detector 4611: Battery voltage < 2.3 V or the Base station (4620) does not receive any detector data.

**FAULT: Primary network, CU xx <-> CU xx,  
Detected by CU xx**

Control unit xx has detected a network fault on the primary network between two control units listed.  
Check cables, connections, etc. This could also mean a faulty 5040 board in either of the two control units listed.  
If the secondary network is ok, the messages will be sent on the secondary network.

**FAULT: Read/write site data (SSW), Control Unit xx**

SSW = the data that is changed during operation, i.e. week average sensor values, access codes, calibration values and event logs, in control unit no. xx.

- If the C.U. was powered down (i.e. mains and battery disconnected) without first doing a Safe shut down of control unit via menu H8/S6 (see page 159), this fault might be generated when the C.U. is powered again. After fault acknowledge the SSW will get default values and the fault will be corrected (serviced). Supervised outputs have to be calibrated via menu H5/A1.
- Some external influence has caused a fault in the SSW. This is very serious. Call for service personnel/engineer.

**FAULT: Restart Control Unit nn,  
code xx, address yyyyyyyyyy**

A restart has occurred in Control Unit no. nn. SSD and S/W download will automatically be followed by a restart. Also, you can manually do a restart, see chapter "Restart", page 108. Regarding the restart codes 00, 03, 13, 14, 25, 50 & 53.

The following restart codes are due to some external disturbance and are not normal, i.e. call for service technician:

- xx=01: Watchdog Reset.
- xx=02: Accidental jump to reset vector.  
xx=04-12: Unexpected interrupt.
- xx=13: Software monitoring fault.
- yy...y = memory address (before restart). Write down the address and inform the service technician.

**FAULT: Second network, CU xx <-> CU xx,  
Detected by CU xx**

Control unit xx has detected a network fault on the secondary network between the two control units listed. Check cables, connections, etc. This could also mean a faulty 5040 board in either of the two control units listed. If the primary network is ok, the messages will be sent on the primary network.

**FAULT: Sensor zone: xxx address: xx,  
technical number xxxxxx**

The analogue smoke, heat or multi detector is faulty. The detector's built-in self-verification function has reported a fault. The detector has to be replaced.

FAULT: Short circuit tech addr nnn <-> nnn, [sub-loop x], loop x,  
Control Unit xx

Tech addr nnn <-> nnn describes between which Short Circuit Isolators the short-circuit is located.

nnn = Technical address for short circuit isolator.

A & B are the built-in isolator in the FT1020G3 FDCIE A-direction and B-direction respectively.

**Note:** Each 10th minute a check is performed, if all short-circuits are corrected (repaired), the communication automatically returns to communicate in one direction only. The fault has to be acknowledged, it can last up to 10minutes after the acknowledgement before the communication returns to communicate in one direction only.

**Note:** This fault might be incorrectly shown if the SA-SB cables are mixed. If no short circuit can be found, run "check loop" from EBLWin to get correct information.

FAULT: Site specific data (SSD),  
Control Unit xx

The Site Specific Data (SSD) in Control Unit no. xx is not downloaded correctly (a checksum fault, etc.). A new SSD download (via EBLWin) is required.

FAULT: Site specific data, alert annunciation unit xx,  
Control Unit xx

FAULT: Site specific data, external presentation unit xx,  
Control Unit xx

FAULT: Site specific data, Fire Brigade panel xx,  
Control Unit xx

FAULT: Site specific data, General control panel xx,  
Control Unit xx

- Alert Annunciation Unit
- External Presentation Unit
- External Fire Brigade Panel
- General Control Panel

No SSD (Site Specific Data) downloaded to the unit or something is wrong in the downloaded SSD.

FAULT: SSD, alert annunciation unit xx,  
Control Unit xx

FAULT: SSD, external presentation unit xx,  
Control Unit xx

FAULT: SSD, Fire Brigade panel xx,  
Control Unit xx

FAULT: SSD, General control panel xx,  
Control Unit xx

- Alert Annunciation Unit
- External Presentation Unit1
- External Fire Brigade Panel
- General Control Panel

No SSD (Site Specific Data) downloaded to the unit or something is wrong in the downloaded SSD.

FAULT: SSD mismatch, General Control Panel xx  
Control Unit xx

The SSD (Site Specific Data) downloaded in the General control panel doesn't match the SSD downloaded in the control unit. A new SSD download (via EBLWin) must be performed in both General Control Panel and the Control Unit.

FAULT: SSD mismatch, General Control Panel xx, Channel x,  
Control Unit xx

The SSD (Site Specific Data) downloaded in the General control panel doesn't match the SSD downloaded in the control unit. A new SSD download (via EBLWin) must be performed in both General Control Panel and the Control Unit.

FAULT: Supervised input x, technical number xxxxxx

A fault on the supervised input x on 4461 / 4462 or 1200 series field modules. Check the cables / connections (cut-off or short-circuit).

FAULT: Supervised output x, Control Unit xx

If the output is programmed for **sounders** or **OWS** (type "Alarm devices"), it is also indicated by LED Fault / Disablements" Alarm devices" blinking.

If the output is programmed for Fire Brigade TX (type "Routing equipment"), it is also indicated by LED Fault / Disablements" Fire brigade TX" blinking.

If the output is programmed for an extinguishing system (type "Extinguishing"), there will be an additional information text close to the soft key area in the display: **Extinguishing wire fault**.

**Supervised (1-50 kΩ):**

x=0 (S0): Short circuit/break on the connected cable/ equipment

x=1 (S1): Short circuit/break on the connected cable/ equipment

x=2 (S2): Short circuit/break on the connected cable/ equipment

x=3 (S3): Short circuit/break on the connected cable/ equipment

Fuse T500mA L 250V

- Calibration not performed via menu H5/A1.
- Connected equipment might be removed.
- Resistor(s) missing or not correct value. (1-5 resistors 33 kΩ)

**Note:** *The calibrated value has to be in the range 1K-50K.*

FAULT: Supervised output x,  
technical number xxxxxx

This fault message is valid for a COM loop output unit 3364 output or 4464 board output.

If the output is programmed for OWS or sounders (type Alarm devices), it will be indicated by LED Fault / Disablements "Alarm devices" blinking.

If the output is programmed for fire brigade tx (type Routing equipment), it will be indicated by LED Fault / Disablements "Fire brigade tx" blinking.

- Calibration not performed via menu H5/A1. (Valid for 3364 only)
- Short-circuit / break on the connected cable / equipment.
- Missing connected equipment.
- End-of-line capacitor(s) missing or not correct value, 1-5 capacitors (470 nF). (Valid for 3364 only)
- End-of-line resistor is missing (Valid for 4464 only)

**Note:** *The calibrated value has to be in the range 470 nF – 5 x 470 nF (2350 nF). (Valid for 3364 only)*

<p>FAULT: Temperature sensor, Control Unit xx</p>
<p>The sensor is not correctly connected, is faulty or is missing.</p>

<p>FAULT: Wrong connections, primary network, detected by Control Unit xx</p>
<p>The order of the control units in the primary network ring doesn't match the order specified in the SSD data. Check cables and the SSD data programming. The connection order must be correct, to get the correct fault messages, but this fault has no impact on the system function.</p>

<p>FAULT: Wrong connections, secondary network, detected by Control Unit xx</p>
<p>The order of the control units in the secondary network ring doesn't match the order specified in the SSD data. Check cables and the SSD data programming. <b>Note:</b> the secondary ring must run in the opposite order of the primary ring. The connection order must be correct, to get the correct fault messages, but this fault has no impact on the system function.</p>

<p>FAULT: Wrong information, Control Unit xx</p>
<p>Can be shown in conjunction with new software download and/or when commissioning a system. This fault can be generated due to unreliable communication problems. One or more Control Units may have data stored that is not the same in all Control Units. If a Control Unit restarts in conjunction with this fault, a synchronisation will start automatically, otherwise a synchronisation has to be started via menu H8/S8 (or via EBLWin). <b>Note:</b> <i>It is important that all existing Control (SSD downloaded via EBLWin) are running and are connected to the network. The network programming has to be done. It will take 90-120 seconds until this fault is corrected.</i></p>

<p>FAULT: Wrong type Expansion Board x loop x, Control Unit xx</p>
<p>This is valid for the I/O Matrix board 4582 no. x connected on COM loop x in the Control Unit no. xx. <b>Note:</b> <i>In 19" rack systems, 4582 circuit is integrated in the new fan / damper (1206/1211) and zone (1205) modules, no type required (fixed).</i></p>

<p>FAULT: Wrong type Expansion Board x, Control Unit xx</p>
<p>Valid for the 8 zones exp. board 4580, the 8 relay outputs exp. Board 4581, mounted in control unit no. xx. Check the type of board, which should be the same as programmed via EBLWin.</p>

FAULT: Wrong type of unit xxxxxx

Check the type of unit, which should be same as the programmed type in EBLWin.

FAULT: Wrong type of unit zone: xxx address: xx  
technical number xxxxxx

Check the type of unit, it should be same as the type programmed via EBLWin.

FAULT: Zone Line Input, Zone xxx Address xx  
CU xx Expansion Board x input x

Valid for the 8 zones exp. board 4580 zone line input x (xxx-xx = zone – address). The board is mounted in Control Unit xx.  
Open circuit on the zone line, wrong / no end-of-line device / short- circuit (if not programmed for fire alarm at short-circuit).

FAULT: Zone Line Input, zone: xxx address: xx  
technical number xxxxxx

Valid for the Multipurpose I/O unit 4461 (or 3361) monitored zone line input Z. open circuit on the zone line or wrong / no end-of-line capacitor (10 uF) or short-circuit (if not programmed for fire alarm at short-circuit).

No contact with main board

Shown only in the affected Control Unit.

- Check that "MMI board" is selected in the SSD (EBLWin Control unit properties).
- Fault in the Main board software or hardware. Check the cable between the Main board and MMI board. It may require system software download, this will erase SSD. Call for service technician immediately.

External fault; User programmable text

Shown only in the affected Control Unit.

Programmable input is connected to any external equipment's fault output. User definable fault message ( $\leq$  40 characters) has to be programmed via EBLWin.

FAULT: Corrupt program area 2, Control unit xx

A fault in the control unit xx MMI board. There is some internal fault on the board

- Try to download S/W again
- Replace the MMI board

## 17.2 Fault Acknowledge

When a fault is generated in FT1020G3, the following may occur:

- The LEDs **Routing equipment** "Fault TX activated" and **Fault / Disablesments** "General fault" are turned on to indicate the output for routing equipment (Fault tx) is activated
- LEDs **Fault / Disablesments** "Alarm devices", "System fault" and/or **Fault / Disablesments** "Fire brigade TX" may turn on as well.
- Output for routing equipment (Fault TX) is activated.
- Output for general fault is activated.
- Output for general charger fault might be activated.
- One or more fault messages including date and time are shown in the Control Unit display.

If "Fault latching" is selected in EBLWin (default), once the fault is corrected, the "Serviced" message will be shown on the display i.e. the fault is already serviced / corrected. When the "Fault latching" check box is not selected in EBLWin, the "Serviced" fault will automatically disappear from the list.

Any already acknowledged fault in the list is indicated by "**Acknowledged**".

Example: Fault messages shown in the Control Unit display:

```

FAULT: No reply zone: 123 address: 01
technical number 000025
"...alarm text..."
2023-11-03 15:22      /Serviced

FAULT: No reply zone: 123 address: 03
technical number 000027
"...alarm text..."
2023-11-07 09:25      /Acknowledge

Number of faults in system: 5

Menu
  
```

To acknowledge the faults shown:

- Login, according to chapter "Access Levels", page 42.
- Use **menu H6** (access level 2A) to acknowledge fault, see chapter "FAULT Acknowledge (H6)", page 148. Menu H6 is a list showing a maximum of 300 faults (not acknowledged faults and/or acknowledged but not serviced / corrected faults).
- All faults must be individually acknowledged one by one using the key pad button ↵, Use ▲ or ▼ to scroll.
- When a fault is corrected before it has been acknowledged, the text "Serviced" is added after the time, still has to be acknowledged to remove from the display.
- When a fault is corrected / serviced and acknowledged, it will disappear from the list (H6).
- When **all** faults have been acknowledged, the output for routing equipment (Fault TX) will not reset and the LED for **Routing equipment** "Fault TX activated" remains activated until there are no faults in the system.
- Whilst faults still not corrected in the system (Acknowledged faults corrected or not corrected), the LED **Fault / Disablesments** "General fault" will be lit and general fault (and maybe general charger fault) output(s) are activated. The fault relay also remains energised.
- Faults, corrected faults and acknowledged faults are shown in the General event log (menu H4/U6).

## 18 Commissioning an FT1020G3

### 18.1 General

**Note:** Ensure to keep the following, in the allocated document space in the cabinet:

1. Hardcopy of the SSD print out report
2. Building layout drawing showing detectors and modules location in the building.
3. Operation Manual.
4. Log book.

No connection, other than the mains power supply should be made, prior to checking the operation of the FDCIE.

Mains power should be turned on and charger voltage levels checked / set. If these levels are correct, batteries can then be connected. Follow the procedures shown in section 18.2 below.

The USB port in 5012 supports Type B, i.e. no requirements in V3.6.x to use external isolator (Brooks BA-PCISO) when the PC is connected to 5012.

Cable resistance readings and field connections must then be checked to ensure they are correct prior to their connection to the FDCIE.

**Tip!** Measure the resistance of each loop wire (L & C respectively) before turning on the power. Check that the L-wire (SA) that goes out on terminal J5:1 comes back at terminal J5:3 and so on. If the loop has short circuit isolators, only the C-wire (SB) can be measured.

### 18.2 Single Control Unit

Once the cabinet is mounted and secured in place, the following power up procedures must be followed:

1. Connect the incoming mains power feed to the GPO, ensure the mains isolator switch is "OFF".
2. Turn "ON" the incoming mains power from the circuit breaker in the switch board.

**Note:** Mains power to be supplied to the FT1020G3 via a two-way circuit breaker.

The mains cable should be securely clamped and the wires be as short as possible, use cable ties to keep mains wires well separated from 24V<sub>DC</sub> wires. The mains safety earth (ground) should, however, be longer than the other wires, to ensure that it is the last to be disconnected if the mains cable clamp should fail. After the installation, the lid protecting the power supply screw terminals should be correctly applied.

**Note:** An in-line fuse (F) rated 6.3A is fitted on the cable between the series batteries, see drawing F822 in Figure 24 "FT1020G3 Standard Block Wiring Diagram" page 177.

3. Turn "ON" the mains isolate switch (230 V<sub>AC</sub>)<sup>31</sup>
4. Connect the batteries to the battery leads provided.
5. LED "POWER" indicates that the 24 V<sub>DC</sub> power supply is okay (PSU and/or battery). Confirm the "Power" LED is the only illuminating LED on the front display.
6. Once the basic operation of the panel is confirmed, remove the battery in-line fuse and disconnect mains power via the isolate switch.
7. Terminate the COM loop and any field wiring into the connectors and plug into the main board.
8. Turn ON the mains power and re-place the in-line fuse to connect the batteries, a restart will now take place (see chapter "Restart", page 108 ).
9. The Site Specific Data (SSD) – created in EBLWin can now be downloaded, see

<sup>31</sup> The Control Unit is supplied with a GPO which has the mains isolate switch and a power point outlet used during programming to connect power to your PC.

chapter "Download SSD", page 93.

**Important note:**

In retrofit applications where main board 5010 and MMI board 5011 are used, the SSD must be imported and control unit must be converted in the SSD when the 5012 and 5015 are required to replace 5010 and 5011. Right click on the control unit to convert to 5012, refer to section 16.2 of EBL512 G3 V3.6X planning instructions in EBLWin "Help".

See also chapter "Calibration of supervised outputs (H5/A1)", page 137.

**Note:** A "Safe shutdown" must be performed once FT1020G3 is cleared of all faults and the system is running in normal operational mode. This is to avoid re-calibrating the supervised outputs should the panel is turned off.

### 18.3 Control Unit in an EBL Ring Network (5040)

**Note:** The EBL ring network can be used only when 5040 network card is used with fibre or copper cables. When 5090 network card is used, wiring via copper cables is in/out.

The ring network is constructed of two rings running in opposite directions. The control units in the network don't need to be connected in control unit number order. The cable types in the network can be either RJ45 copper or fibre. A network ring can use different cable types in different parts of the ring.

All communication is point-to-point between the control units. Messages are received and repeated forward in the ring network. When a control unit receives its own message, that's the confirmation that the message has been reported to the entire network.

In a redundant network, two network boards (5040) have to be plugged in each control unit, primary network and secondary network i.e. Network no. 0 and Network no. 1. The secondary network is the back-up board (Network no. 1), and is only in supervising/monitoring mode until primary network (Network no. 0) stops communicating properly.

Normally only the primary network is in use, and in case of a network fault i.e. open circuit or short circuit, the secondary network will be automatically used until the primary network restores communication. The redundant network supports full functionality in case of a network fault in one of the two networks.

**Network cables:**

The cable types in the network can be either copper or fibre. A network ring can use different cable types in different parts of the ring.

- Ethernet cable FTP Cat 5e or better for copper, max 1000m in each segment.
- Optical fibre multimode 62.5/125um with ST-connector, max 1500m in each segment

Example of ring network

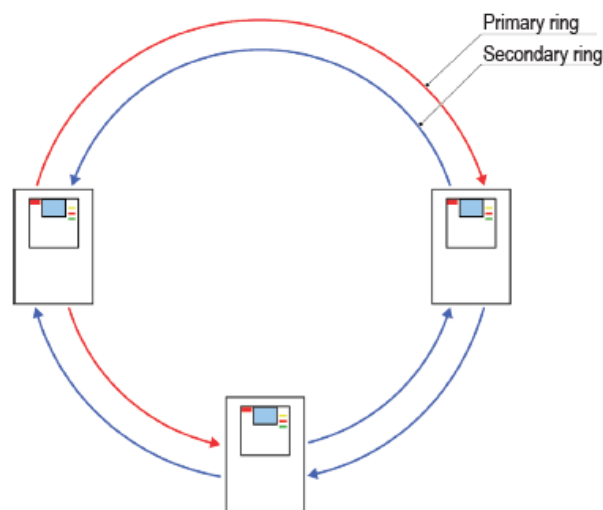

## 18.3.1 Network Board 5040 Installation

When the control unit is equipped with a network board 5040, the lowest S/W version is 3.0.0. The current and only released software in V3 versions is V3.6.

1. Mount two network boards 5040 on the main board.
2. Connected the network cables fibre or ethernet directly to the network boards.
3. For each control unit, repeat procedures shown in section 18.2 Single Control Unit.
4. When all control units are powered, start the programming in EBLWin.. (See below EBL Ring Network Programming (Redundant)).

## 18.3.2 EBL Ring Network Programming

### 18.3.2.1 Set Control Unit Number

1. Program the system in EBLWin version 3.6.X or higher. In the System properties dialog box, 5040 is selected by default as type of network.
2. Log on to the control panel.
3. Select Tools menu / Set control unit number. Set the number on control units in the network as follow:
  - Enter the main board serial number for the control unit (Serial number found on the product label). The main board serial number of the control unit EBLWin is connected to, is automatically filled in.
  - Enter the ID number. The ID number is the same as the control unit number in the EBLWin tree view.

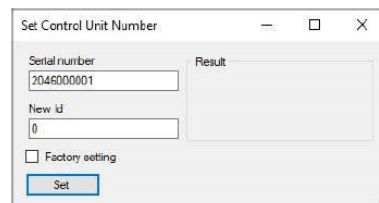

4. Click "ok", the control unit number is now stored in the flash memory in the main board. The main board will restart, and start using the new number.
5. Continue with the next control unit in the network until all units are given an ID.

**If the control units are not yet connected in the network.** Log out from the control unit. Connect to the next control unit. Follow procedure above 2 to 4. (Note that there might be "Timeout" in the control unit when logging out, because EBLWin will try to log out from control unit 255, which it first connected to, but that control unit number is not existing anymore).

**If all control units are connected in the network,** just enter the next serial number and ID.

### 18.3.2.2 Set the Control Unit Order

**Note:** Before starting this procedure, all control units must be connected in the network, and the control unit numbers must be set for each control unit.

Specify the order of the control units in the primary network ring. This can be done when creating the SSD, in the System Properties dialog box.

There are two ways to do the setting of Control Unit Order: **Automatically** or **Manually**

For **Automatic** setting,

- a) In System pop-up menu, select Check network. EBLWin will scan the network and present the status of the network ring graphically. A fault in the network will be shown graphically with a yellow warning sign. The graphical view will also indicate, with a dotted line, within which network section of the non-responding control unit can be found.
- b) Repair any faults and click Start to resume.

- c) When the statuses of both network rings are OK, click the *Set network ring order button* (at right-bottom corner) to automatically apply the order of the control units.

For **Manual** setting,

- a) In the System properties dialog box, Network Ring Order tap, manually enter the ID number (= control unit number) separated by comma (individual numbers or a range of numbers), for example 1, 2, 4-10, 3.
  - b) Click OK to save.
1. After the control unit IDs have been set, the order of control units in the primary network ring have been set, Download the SSD.

**Note:** The order of the control units in the secondary ring must always be the opposite of the order in the primary ring. Refer to EBL Ring Network Manual for more details

## 18.4 Control Unit in a TLON Network

### 18.4.1 Control Unit in a TLON Network

The FT1020G3 system can be built as a single TLON Network or as a redundant TLON Network, i.e. 2 networks (dual path).

In the **single TLON Network**, one TLON connection board (5090) has to be plugged in each Control Unit (Network no. 0) whereas in the **redundant TLON Network**, two connection boards (5090) have to be plugged in each Control Unit.

**Note:** Single TLON network is used only when additional main board is to be fitted inside the same enclosure otherwise a redundant TLON network is used i.e. two TLON boards 5090 must be used in each control panel. A single TLON Network is a violation to the Australian standard AS1670.1.

If 2 x 5012 boards installed in the same cabinet but connected to other remote FT1020G3 in a TLON network, the second TLON must be added.

The redundant TLON Network supports full functionality in case of a network path failure, i.e. open circuit or short circuit in one of the TLON networks.

When the 5090 boards are plugged-in and the network cables are connected<sup>32</sup>, **for each Control Unit**, the same procedures as for a single Control Unit must be followed, see steps 1-9 above.

When all Control Units are powered, the TLON network installation (see below) must be performed **before** the Site Specific Data (SSD) can be downloaded, see chapter "Software Installation and SSD Download", page 93. TLON Manager software V2.01 is used to configure the network ID for each control panel.

For more details, refer to TLON technical / operation manual M437.

---

<sup>32</sup> The TLON connection board is mounted on the main board. Network cable connections are made on the main board, terminal block "J4".

## 18.5 Upgrade Number of Alarm Points

All FT1020G3 settings are normally factory downloaded before delivery, default setting is 1020 addresses. However, the number of addresses is configurable to 128, 512 or the default setting 1020. Note that the maximum number of COM loop addresses (software version  $\geq$  V2.8) is always 1012, i.e. address 1 – 253 on each COM loop. Address 254 and 255 are allocated for auto addressing function.

If the number of addresses is 128 or 512, you require upgrading the number of addresses, a PC and **EBLWin** are used. Before starting the upgrade process, the PC is to be connected to the USB connector in the Control Unit and the hardware key is also plugged in. Open EBLWin and the FDCIE where the upgrade is to be performed and follow the procedures below:

1. Logon (Tools | Log on Control unit...)

2. Select the Control Unit icon, right click and in the pop-up menu select "Upgrade number of alarm points". A dialog box opens as shown.

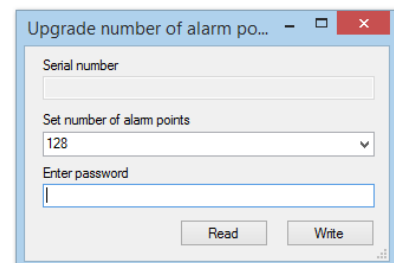

3. Click "Read" to get the serial number from the Control Unit you are connected to, normally the no. of alarm points is 512 as shown.

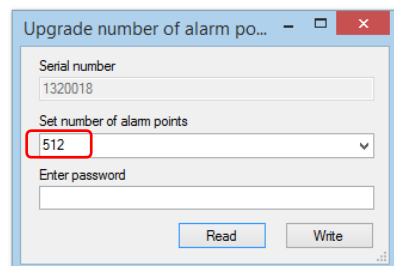

4. A special PC program is used to generate the password in the factory or report the **Serial number** to Brooks engineering office to generate the password. The password will be unique for every serial number and number of alarm points combination.

5. Write the new number of alarm points and the generated password in the field respectively and click "Write".

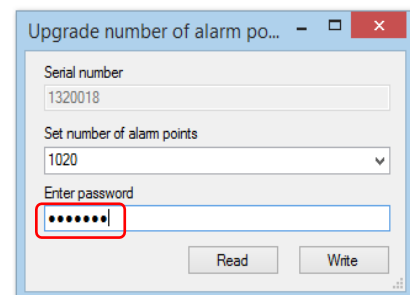

Follow the same procedure in each Control Unit if a TOLON network requires upgrade.

After you enter the password, right click on the respective Control Unit icon and choose "Properties". The Control Unit Properties dialog box opens:

Depending on the upgraded password you received, under the "Misc" section, the "Configured number of alarm points" will be made shown.

**Note:** All Control Units connected in a network are not required to have the same maximum number of alarm points.

# 19 Software Installation and SSD Download

## 19.1 EBLWin Software Requirements

To install EBLWin software in your PC, the instructions in this chapter must be followed, the instructions apply only to any software versions  $\geq$  V2.0.. For TLON installation refer to TLON Technical / Operation Manual M437.

### Required files:

The following files must be copied in your PC:

1. Windows .Net Framework V4.7 or above (if Windows did not install it as part of its updates), normally it will be available in your PC.
2. USB driver V2.12.28 for EBL512 G3 and EBLSniffer.
3. Sentinel\_LDK\_Run-time\_setup file named HASPUserSetup.exe. **If not working**, download the latest sentinel LDK Run-time software (free) from <https://cpl.thalesgroup.com/software-monetization/sentinel-drivers> (Sentinel\_LDK\_Run-time\_setup\_8\_53)
4. EBLWin V3.9 file named EBLWin.msi and setup.exe
5. Australian\_EBL512G3\_390 .BIN or NewZealand\_EBL512G3\_390 .BIN
6. Firmware Manager V1.3.4

### Hardware required:

1. EBLWin key 5094
2. USB Type A to USB Type B cable
3. Laptop with Win10 or Win11



The order of prerequisite software and drivers installed before EBLWin is important and must be followed as explained in this chapter.

**Important Note:** some software programs **cannot** be installed due to the privilege added by IT mangers. Adm rights must be provided to enable software installations.

## 19.2 EBLWin Installation Procedures in a PC First Time

### 19.2.1 .NET Framework

If running on Windows 10 or Windows 11, it may already be installed as part of its system. To ensure that

.NET is turned on, click on windows start and type the keyword “Windows Features” and ensure that .NET Framework are turned on as shown below:

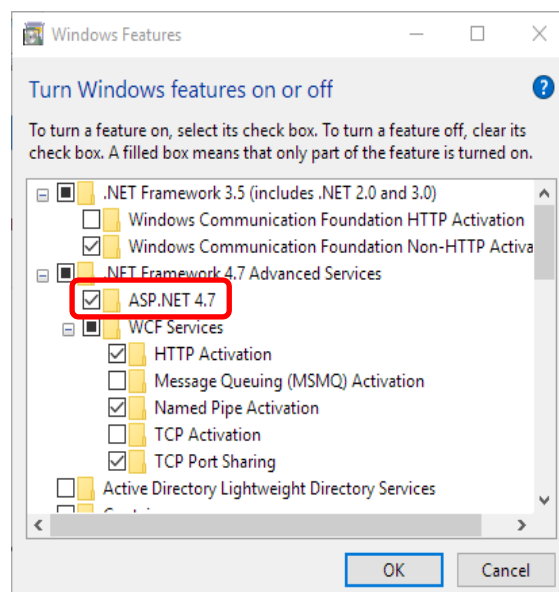

## 19.2.2 USB Drivers Installation

EBLWin communicates with FT1020G3 via USB. Since the control unit is unknown to Windows, drivers must be installed. The **new signed driver** is available in Brooks website.

The driver software will be installed as two devices; one device is **USB controller** and one device is **USB serial port**.

The procedures below describe the driver's installation procedures for Win10 or Win11:

1. Connect a USB cable from your PC to FT1020G3 (driver's software should be saved in a new folder in your PC).
2. Windows displays two messages **"We are setting up a new device"** and a few seconds later **"Your device is set up and ready to go"**. Ignore these messages.
3. Open the device manager by right-clicking on the Windows Start-button and select Device manager. **You need to be an administrator of the PC to access the device manager.**
4. Locate **"Fire Alarm CU EBL512 G3"** under **"Other devices"** as shown below.

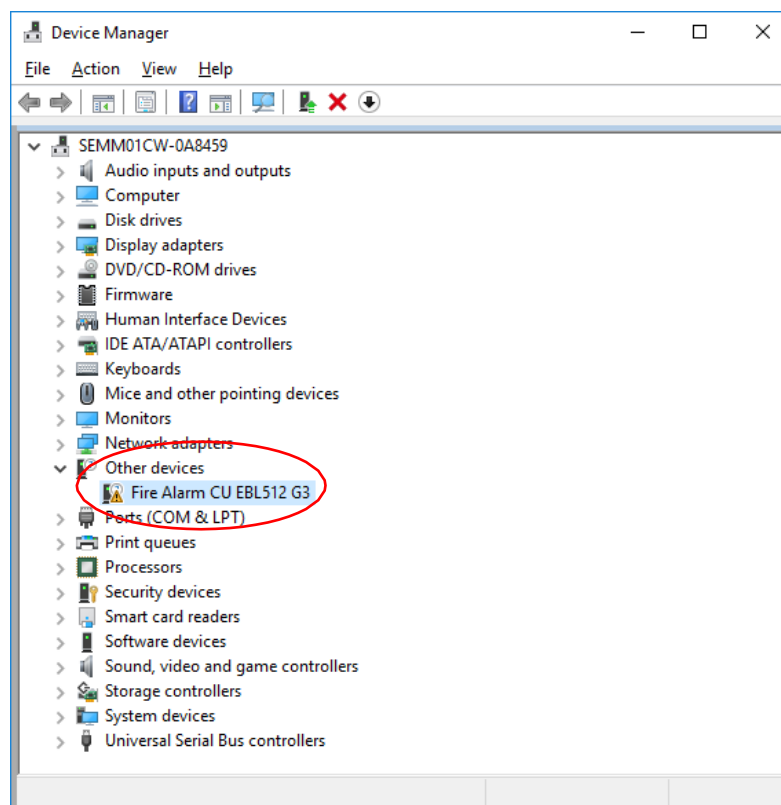

5. Right click on **"Fire Alarm CU EBL512 G3"** and select **"Update Driver"**, the following dialog is shown.

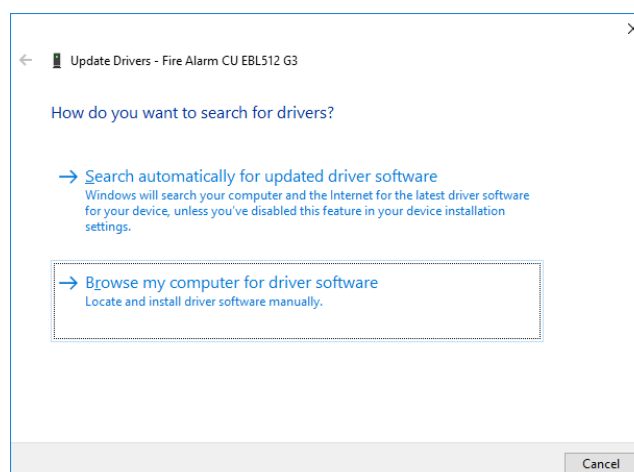

6. Select **“Browse my computer for driver software”**, the following dialog is shown.

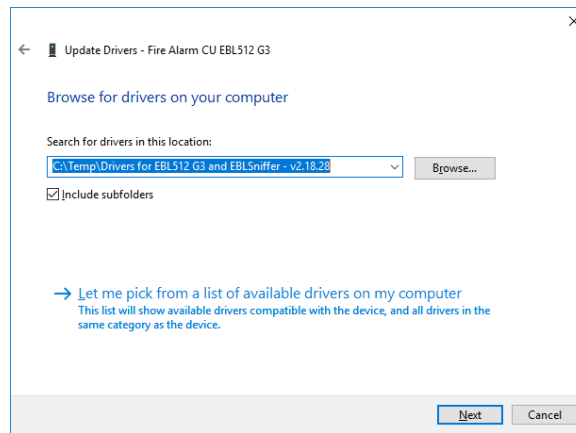

7. Browse to the folder which contains the un-zipped drivers and click **“Next”**.
8. Windows will now install the drivers, you should see the following dialog:

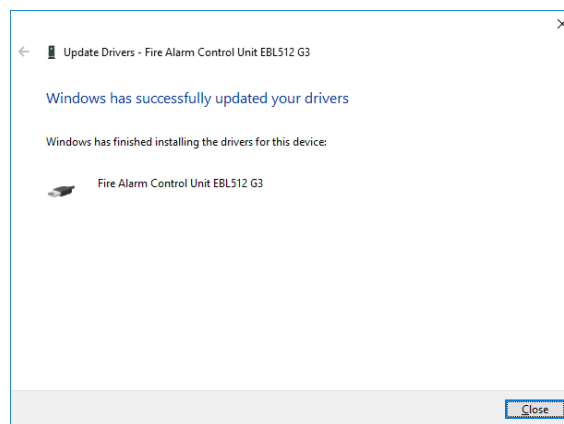

9. Click **“Close”**, the installation of the USB controller is now complete.
10. Go back to the device manager and locate **“USB Serial Port”** under **“Other devices”**

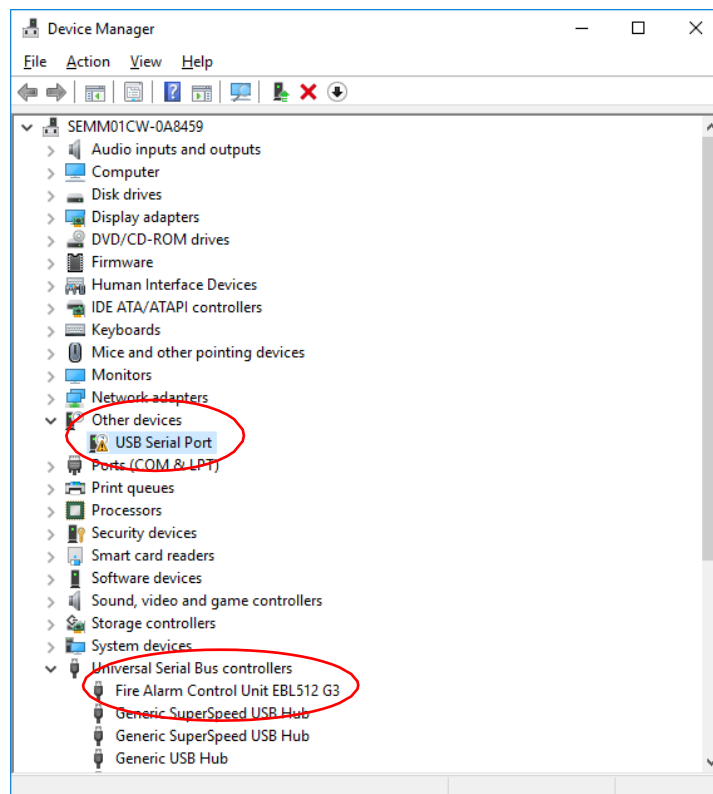

11. Right-click on **“USB Serial Port”** and select **“Update Driver”**, follow the same procedures as per **“Fire Alarm CU EBL512 G3”** to update the USB serial port. When completed, click **“Close”**. Before clicking Close, make a note of the COM-port number shown in the title row of this dialog (COM7 in this case). This COM-port number should be used in EBLWin / EBL Firmware Manager when logging on or downloading firmware to the control unit.
12. The driver installation is now complete. In the device manager there should now be two entries for EBL512 G3 and the COM port number will also be shown:

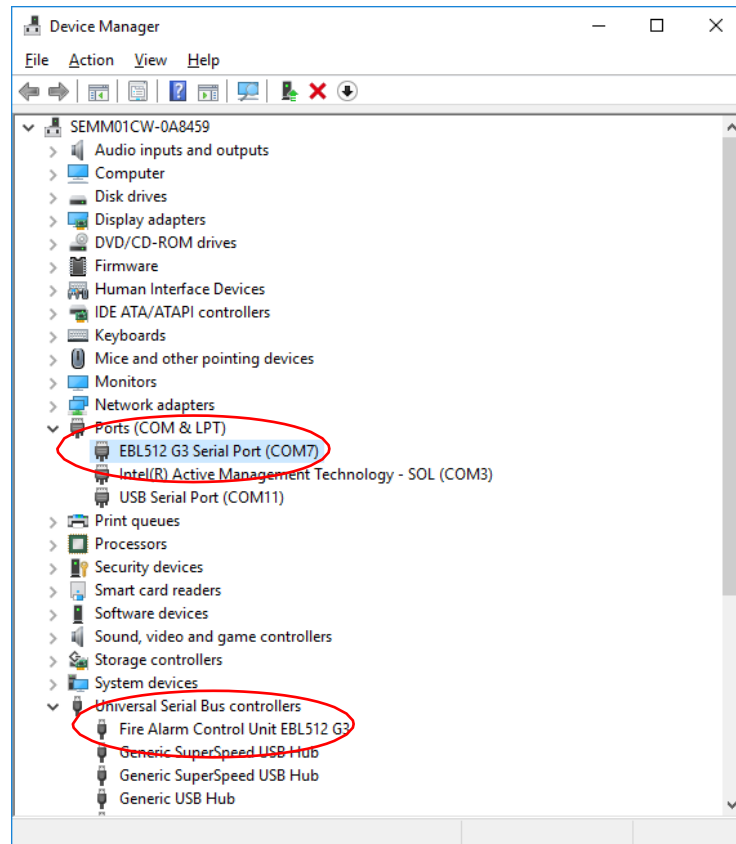

Figure 19 Final Display Device Manager

**Note:** The USB drivers for FT1020G3 is also used for the wireless check tool EBL Sniffer.

### 19.2.3 HASP Driver Installation<sup>33</sup> (for 5094 key)

Install the HASP driver for key 5094 “Sentinel\_LDK\_Run-time\_setup”:

**Win7:** Right click on HASPUserSetup.exe and choose “Run as Administrator”

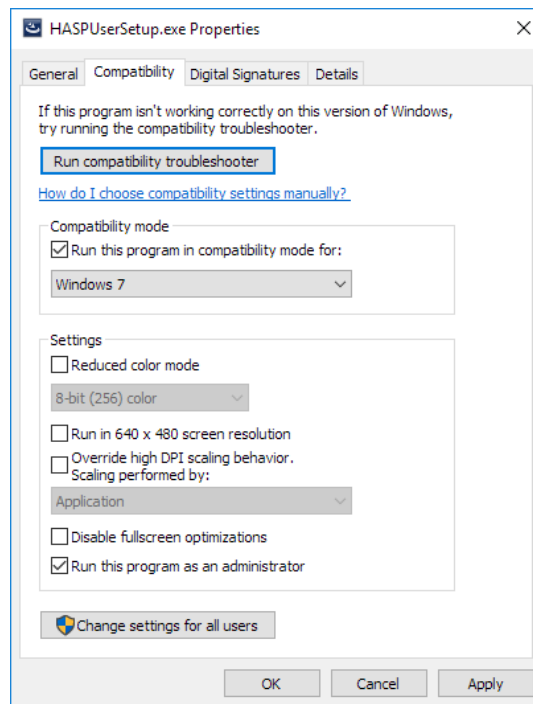

Figure 20 Installing HASPUserSetup in compatibility mode

**Win10 or 11:** Right click on “HASPUserSetup.exe” and choose properties then go into the Compatibility tab. Set as shown in Figure 20 above and click “OK”.

**Note:** If the HASP driver cannot be installed, you may need to download a recent version of Sentinel\_LDK\_Run-time software, it is free downloaded from ThalesGroup website.

### 19.2.4 EBLWin software Installation

1. Unzip eblwin\_391 zip file and double click on the file named EBLWin.msi, the following dialog display

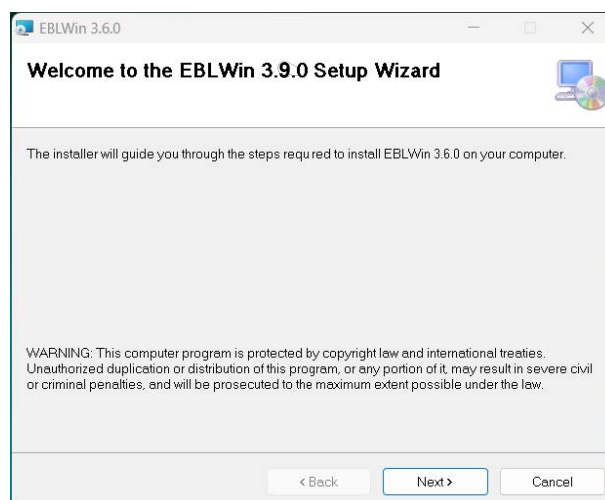

2. Click “Next”, the following dialog will be shown:

<sup>33</sup> HASP driver may not install properly in the latest revisions of Windows 10 or Windows 11. Check Brooks website to install the suitable driver.

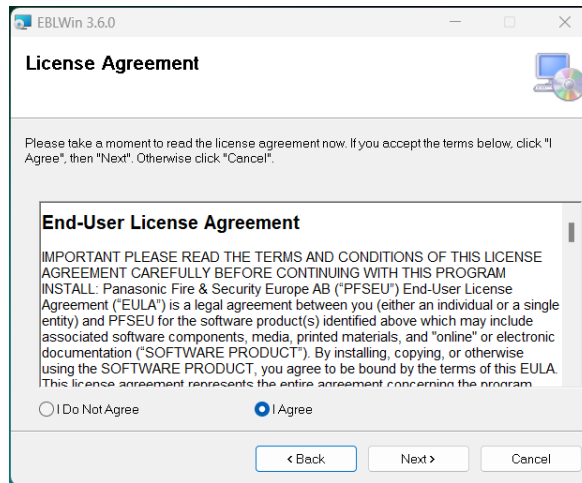

3. Click "**Agree**" then "**Next**", the following dialog will be shown

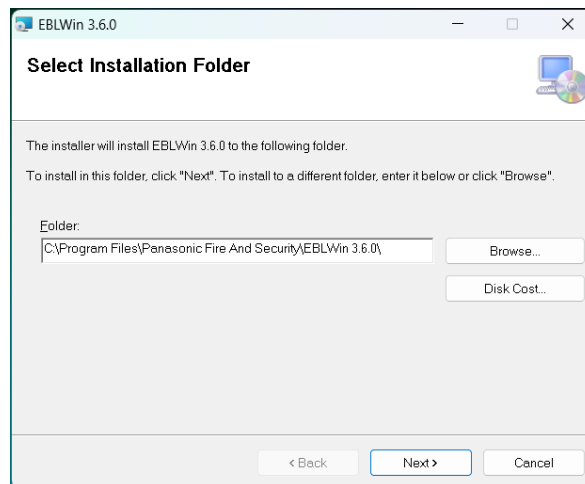

4. Browse to the unzipped eblwin\_391 folder saved in your PC and click "**Next**", the following will be shown:

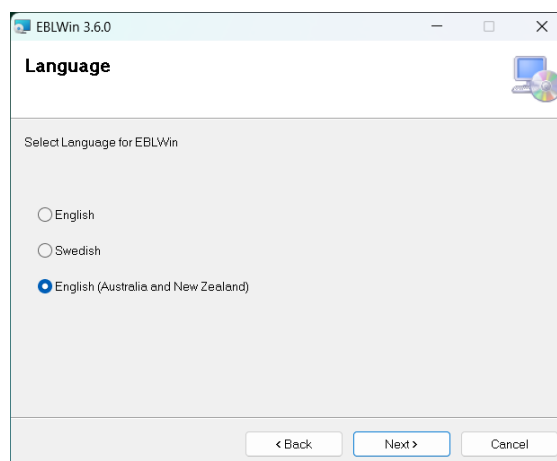

5. Select "**English (Australian and New Zealand)**" and click "**Next**", when the "**Confirmation Installation**" window appeared, click "**Next**". The "**Installation Complete**" dialog will show, click "**Close**" to exit the installation.
6. Launch EBLWin, the following will show:

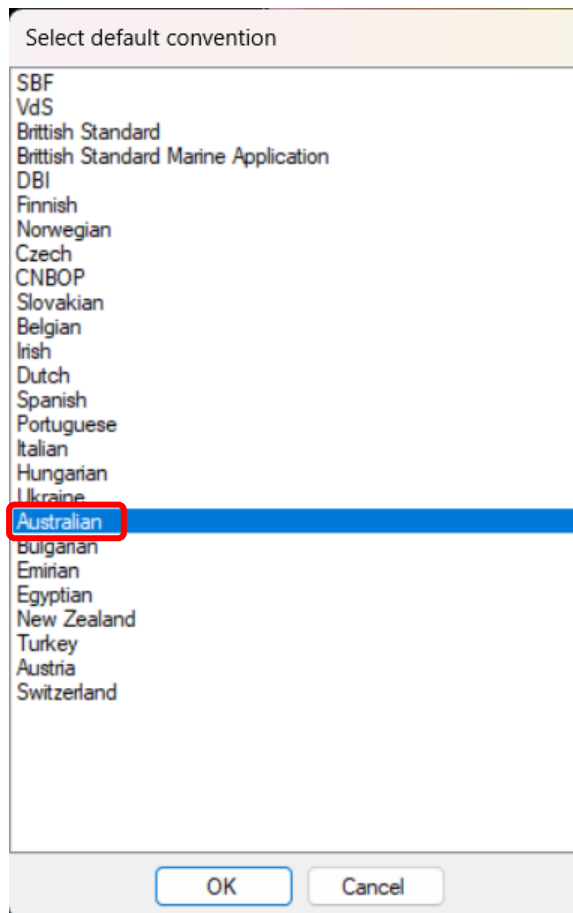

7. Select “**Australia**” for the Australian convention or “**New Zealand**” for NZ convention (only for systems used in NZ).
8. Plug in EBLWin key 5094 into another available USB port
9. Go to Tools > Log on control unit, the COM port number in Figure 19 should be displayed.

**Note:** First time to launch EBLWin, ensure to select “Australia and New Zealand”. If any other convention has been selected, the 19” modules will not be shown and can’t be programmed.

## 19.2.5 Installation of EBL Firmware Manager

1. Unzip “**EBL Firmware Manager V1.3.4**” zip file and double click on the file named **EBL Firmware Manager.msi**, the following dialog display:

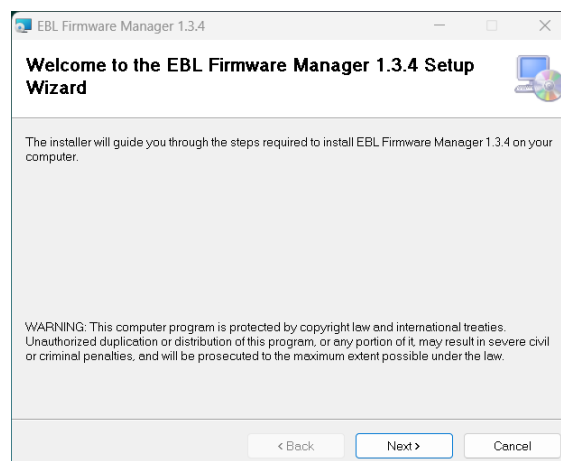

- click **“Next”**, the following dialog displays:

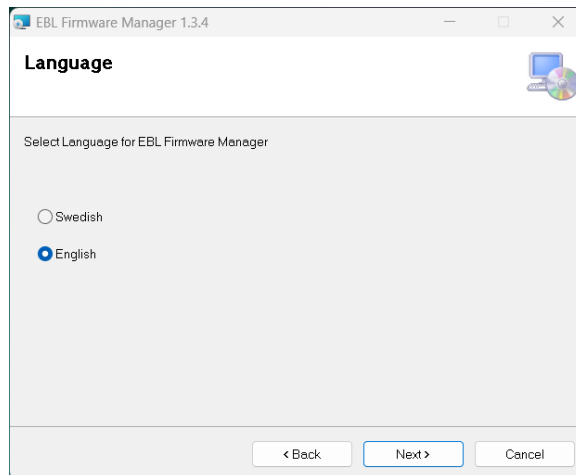

- Select **“English”** then **“Next”**, The dialog below shows where the EBL Firmware Manager will be installed. Click next.

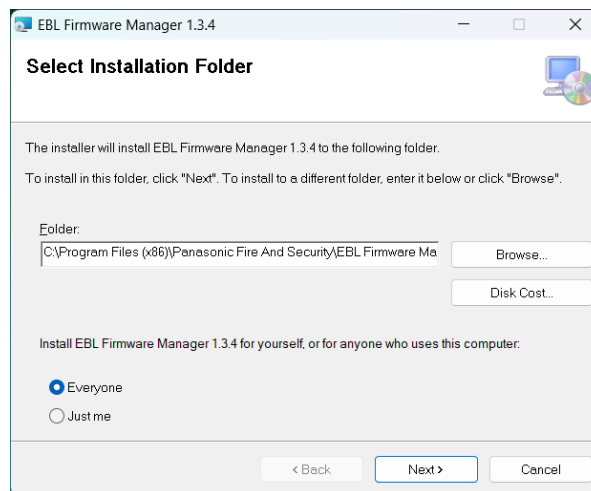

- The **“Confirm Installation”** window will display, click **“Next”** and the installation will be completed as shown below.
- Click **“Close”** to finish installation.

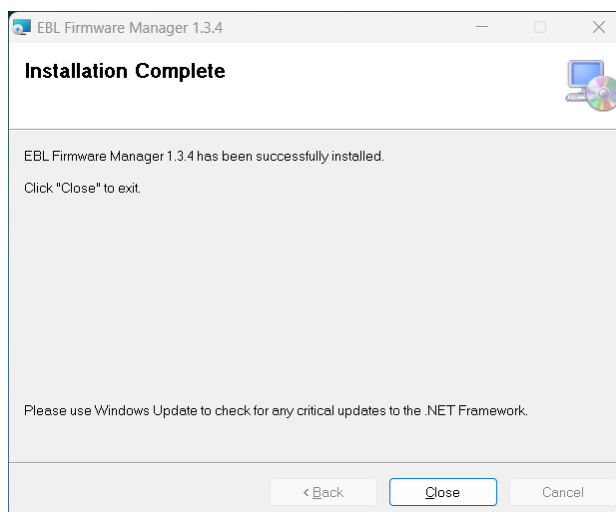

**Note:** If EBL Firmware Manager is not installed in your PC, you may not be able to download the firmware to the FT1020G3.

## 19.2.6 Download SSD

**Note:** An EBLWin USB key (5094) must be used to communicate with FT1020G3 i.e. download the SSD and software using EBLWin ≥ V3.6.x

The PC program **EBLWin** is used for creating the Site Specific Data (SSD) and to download it into the FT1020G3 Control Unit(s), the gateway and/or display units.

**Note:** If the SSD is created using main board 5010 and required to be used with 5012, the SSD file in any FT1020G3 must convert to 5012 format. Right click on “**Control unit**” and select “**Convert to Control Unit (with main board 5012)**”.

The SSD will be saved in a file named **xxxxx.EBL** (xxxxx is the project name).

The EBLWin key 5094 is a protection USB device that must be connected to your PC to enable you to logon to the Control Unit, it has a unique number. The EBLWin key identification number will be registered in the control panel event log with the date and time stamp for every SSD download performed in FT1020G3.

When the installation is ready, i.e. all units connected and the power is turned on, the SSD download can be performed.

**Note:** When a number of Control Units are connected in a TLO network, the network should be running before the SSD download can take place.

### 19.2.6.1 Version Control for SSD Download

When the Download SSD window is opened in EBLWin, EBLWin checks that the SSD file originates from the SSD in the control units. The check starts automatically when the download SSD window is opened. It is not possible to start SSD download until the check is completed (or timeout occurs).

If the check shows that the SSD doesn't match the SSD in one or more control units, there will be a dialog window, asking if the download shall proceed anyway.

In a networked system all control units will be checked.

### 19.2.6.2 SSD Download procedures:

1. Connect the PC to the USB port (type "B") in one of the Control Units.
2. Start EBLWin and open the required project.
3. Log on to the Control Unit via the PC (EBLWin).

**Note:** An EBLWin key 5094 is required to log on to the control unit. This key is plugged in a USB-port in your PC / Laptop. Make sure you have the EBLWin key HASP driver installed on your computer.

4. In EBLWin, go to **Tools** menu / **Download SSD...** Select the control units as well as the Display Units (if fitted), to which the SSD is to be downloaded.
5. Click **Start** to start the download. The progress bar will indicate for each control unit the download progress as shown below.
6. “Control unit download count” / “Document download count” numbers should match. See version control for SSD download above.

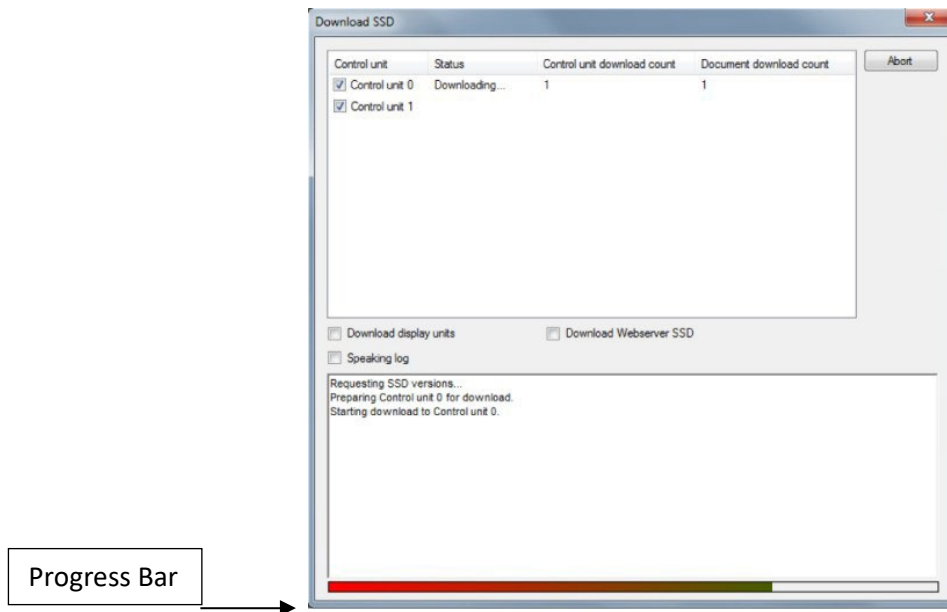

The download will not be completed until the following box is shown:

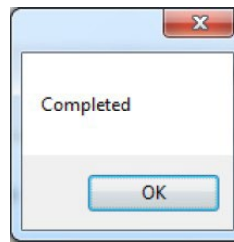

7. Click **“OK”**

After the SSD download, the FT1020G3 will restart. A number of faults may then be generated due to the loop units being not connected yet. This will cause "heavy traffic" on the network, which might affect and delay of the SSD download to the other units.

**Disconnected at start up**

In the COM loop properties dialog box, the **"Disconnected at start up"** check box can be selected. The COM loop will then be disabled directly after the download restarts and therefore no faults will be generated.

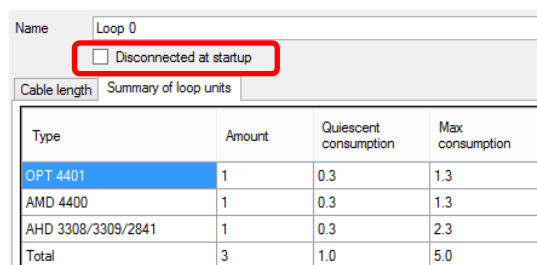

Note: A COM loop "Disconnected at start up" can be re-connected via menu H8/S1 but it will be disconnected again after next SSD download. Finally, the SSD for that Control Unit has to be downloaded again with the option "Disconnected at start up" not selected.

For more details, refer to EBLWin "Help" instructions.

## 19.2.7 SSD Download Messages of a Single Control Unit

1. Start the SSD download from EBLWin as shown above. In addition to the progress bar in EBLWin, a text message will be shown in the FT1020G3 display "Downloading SSD". When the download is completed and the Control Unit restarts, a fault message will be shown in the display:

```
FAULT: Restart Control Unit nn, code 25
DD-MM-YYYY   HH:MM
```

Code 25 indicates a normal restart after the SSD download.

2. Acknowledge the restart fault. If the download was unsuccessful, another fault will be generated

```
FAULT: Site specific data (SSD), CU nn
DD-MM-YYYY HH:MM
```

This text message means that the SSD file has **not** been downloaded successfully, i.e. a new download to be carried out.

## 19.2.8 SSD Download to Control Units in a TLON Network

The SSD for all Control Units can be downloaded via a PC / EBLWin, connected to one Control Unit. The download will be performed to the Control Units, one at a time, according to chapter "Single Control Unit" above. The download is performed in a consecutive order, i.e. 0-1-2-3-4-.....-29 amongst the selected Control Units but the Control Unit where the PC is connected will automatically be the last one to get the SSD downloaded.

When the SSD download is completed, the Control Unit connected to the PC will automatically restart and generate a restart fault.

## 19.2.9 User Definable Text messages Download

Each alarm point, zone and zone line input can have a unique user definable alarm text programmed via **EBLWin**. When a fire alarm is activated e.g. an addressable alarm point, the presentation number (Zone - Address) will be shown in FT1020G3 display and in all the remote display units together with its alarm text.

All alarm text messages are created and downloaded via **EBLWin**.

A Fault message for an alarm point, zone or zone line input will also show the text message (software ≥ V2.0.0).

## 20 Download Software (System Firmware)

The latest software version of EBL512G3 system software<sup>34</sup> is factory downloaded before delivery. Due to continual development and improvement, different S/W versions may be found.

The valid S/W version for the main board and the MMI board respectively, can be read in menu H4/U8 (Information) or via EBLWin.

FT1020G3 can be upgraded with a new S/W version, downloaded on site via EBLWin or EBL Firmware Manager.

### 20.1 Download System Firmware to Single FDCIE

**Note:** Before downloading a new software in **existing system**, SSD backup (upload) must be performed using compatible EBLWin (or WinG3) software then saved in the new version of EBLWin you intend to use. Downloading new system software will delete the existing SSD in the control unit.

A standard single FDCIE should not have any network board mounted. When a FDCIE has a network connection boards 5040/5090 mounted, it is expected to be a control unit in a network and network programming is required.

To download a new software (system firmware) version, a PC and **EBLWin** and EBL Firmware Manager are used. The .BIN file required to be downloaded contains software for the main board 5012, MMI board 5015 and a text file, i.e. there is one BIN file for each convention (AU or NZ).

The latest EBL Firmware Manager software V1.3.4 should have been installed as shown in section 19.2.5 page 99.

The following procedures to be performed to download the system software to the FDCIE utilising EBL Firmware version 1.3.4, valid for main board 5012 (or 5010):

1. Plug in the **USB key** (5094) into a spare USB port on your PC.
2. Connect the PC to the USB connector in the FDCIE and Start EBLWin, **do not logon to FT1020G3**.
3. In the **Tools** menu, select “**Download Software...**” to open **EBL Firmware Manager** dialog box and set as required.

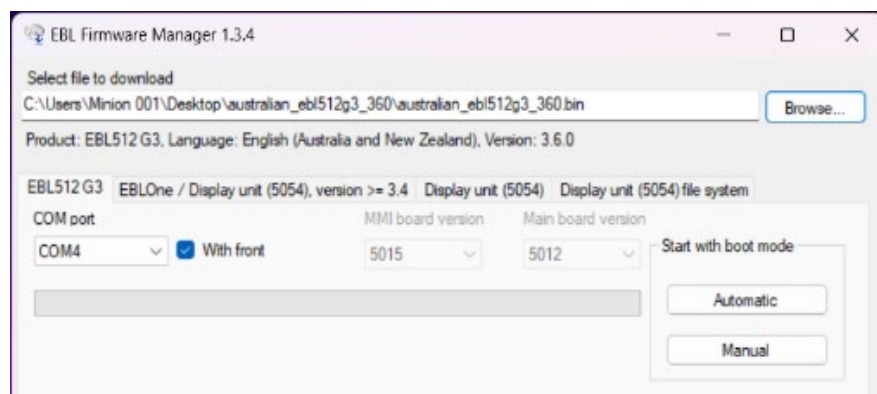

**Note:** Make sure the EBL Firmware Manager program is installed on your computer.

4. Browse your PC to the path and the software file name for the required firmware version, e.g. **Australian\_ebl512g3\_390.BIN (390= version 3.9.0)**.
5. Tick the check box “With front” to select the control panel with front membrane, if the control panel is not fitted with front display, do not tick the check box “with front”.

<sup>34</sup> The software (firmware) is the system software and always uses “EBL” abbreviation.

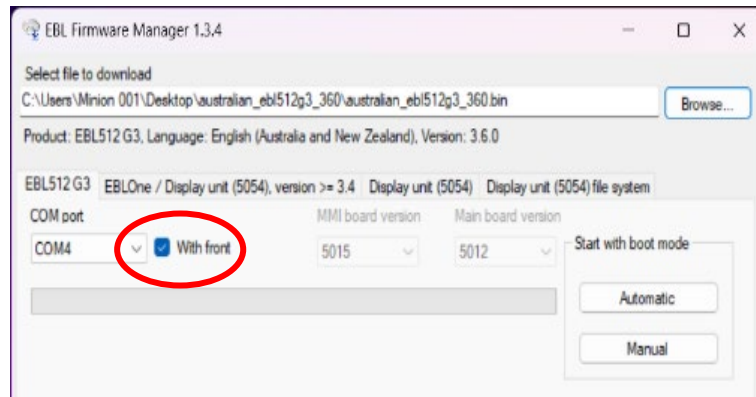

6. Select the COM port to be used on your PC<sup>35</sup>. **Do not** click "Start" yet.
7. Select MMI board.
8. Select main board.
9. If manual boot mode is to be used:

Set the main board 5012 in "boot" mode: Hold the "BOOT" button (SW2) down and push the "RESET" button (SW1) momentarily. Release the "BOOT" button. The main LED "D24" is turned off while the main board is in "boot" mode.

10. Click "**Start**" to start the download. Another dialog box opens when display is fitted.

You must never be logged on to the control unit via the PC (EBLWin) at the same time as the control unit is in boot mode. The fusible resistor R6 on the main board might burn.

11. If possible, use automatic boot mode, click **Automatic**, otherwise **Manual**, to start the download.
12. When the progress bar has finished to the end of the bar, the download will be completed and the following dialog box opens:

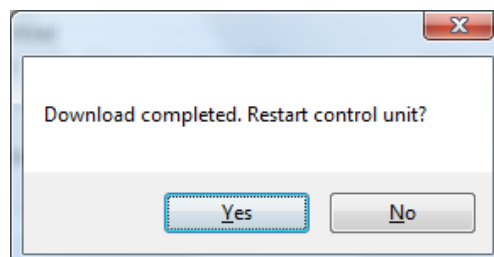

13. Click "Yes" and the Control Unit will restart.

After the restart, the following fault messages will be shown:

FAULT: Restart control unit nn, code 00  
DD-MM-YYYY HH:MM

FAULT: Restart control unit nn, code 50  
DD-MM-YYYY HH:MM

Code 00 / 50 indicates a normal restart of the main board / MMI board after the software download. Acknowledge the restart faults.

<sup>35</sup> If several USB ports are used on your PC, and you want to find which COM port is connected to the panel, go to Device Manager and look for EBL G3 Serial Port (COM#) under Ports, # will be the COM port number.

14. Acknowledge the restart faults, LED "Operation" on the FT1020G3 front should now be turned on and all other LEDs should normally be turned off.

New SSD can now be downloaded.

**Note:** After a new software download, the logon password reverts back to the default setting i.e. "000000". The user names and passwords will be changed when the SSD is downloaded.

## 20.2 Download Software in a TOLON Network

All Control Units connected to a TOLON network **must** have the same software version. Also, in a network system, the system software is downloaded separately to every FDCIE.

Before upgrading the software in a TOLON network, it is recommended to disconnect the control units from the network. It can be carried out physically (disconnect the network connections TOLON cable from the FDCIE) or via TOLON Manager.

**Note 1:** It is highly recommended to disconnect the TOLON network during upgrade in large networks. Otherwise, it will result in large amount of fault messages.

**Note 2:** The TOLON PCBs 5090 must remain mounted in the control units, or the control units will lose their TOLON network configuration.

To download new software in each Control Unit, follow the procedures below:

1. Disconnect the gateway, RS232 in the FDCIE (if any).
2. Open TOLON manager in your PC. Connect the FT1020G3 System to TOLON Manager and set all control units to "Offline".

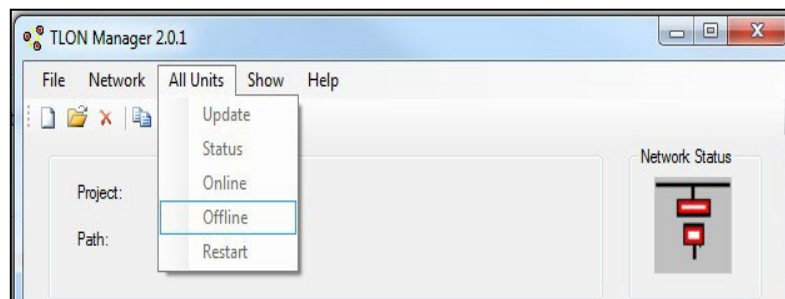

3. Follow the procedure 1 to 14 in section 20.1 page 104.
4. One by one, as the control units start up after download, they will automatically get "online" in TOLON Manager, and the communication will start to run as normal.
5. Download compatible software in the gateway via TCP/IP (if any).
6. Download SSD to the control units, follow the procedures shown in section 19.2.6 page 101. In large systems, it is preferable to download SSD to one control unit at a time. This is to avoid a large amount of traffic on the TOLON network.
7. Re-connect the gateway in the Control Unit (if any).

**Note:** If the downloaded S/W version is only a small bug-correction, there is no need to follow the procedures above. If so, download S/W to one control unit at a time, and then in the control unit, acknowledge all the 'No contact' faults.

If the software download carried out with TOLON network connected, some Control Units will not have contact with other Control Units during the downloading, the following fault may be generated:

FAULT: Control unit nn has no contact with Control Unit nn,  
network x  
dd-mm-yyyy hh:mm

Since control units with new and old S/W will have different information, there will be "wrong information" fault messages.

FAULT: Restart control unit nn has wrong information  
dd-mm-yyyy hh:mm

The faults should be acknowledged.

**Note:** In large TLON networks, there might be a large amount of fault messages generated.

## 20.3 Download Software in an EBL Ring Network

All control units connected to a network must have the same software version V3.9

Also, in a network, the software is downloaded separately to each and every FDCIE.

1. Disconnect the gateway, RS232 in the FDCIE (if any).
2. Follow the procedure 1 to 14 in section 20.1 page 104.
3. Download compatible software in the gateway via TCP/IP (if any).
4. Download SSD to the control units, follow the procedures shown in section 19.2.7 page 103.
5. Re-connect the gateway in the CIE (if any).

## 20.4 Software Versions

Due to continual development and improvement, different S/W versions can be found.

The S/W versions listed in Table 16 below are the valid S/W when this document was release (the date of this document or date of revision).

Table 17 Latest Software Versions for FT1020G3

Software version for:	Latest version	Required version
Standard FT1020G3	3.6.0	3.6.0 <sup>36</sup>
4580: 8 zones expansion board P.C.B no. 9287-2B	1.0.5	1.0.2
4580: 8 zones expansion board P.C.B no. 9287-3A	2.0.10	2.0.4
4581: 8 relays expansion board	1.0.2	1.0.2
4582: I/O Matrix board (discontinued)	1.0.4	1.0.2
5090: TLON connection board	1.1.0	1.0.0
5054 Display unit V3	3.6.0	3.6.0
EBLWin	3.6.0	3.6.0
TLON Manager	2.0.1	1.2
5088 Gateway	3.6.0	3.6.0

**Note:** The EBLWin version and the EBL system software and Gateway software version must be the same, at least the first two digits; 3.9.x – 3.9.x

Main board 5012 require S/W version 2.10.4 or higher.

Network board 5040 require S/W version 3.0.x or higher.

<sup>36</sup> V2.10.4 can be used with 5012 and 5015 but without V3.6 features

## 21 Restart

A restart may delete some data in FT1020G3. Below follows an explanation of the different data and abbreviations and a table describing the different reset alternatives and how the data respectively is affected (**cold** or **warm restart**).

**FF** = Fire alarms and **F**aults.

**D** = **D**isablements

**FFD** = Fire alarms, **F**aults and **D**isablements.

**SSW** = Sensor min. / max. values & performance factor, supervised output calibration values and event logs.

**WASV** = **W**eek **A**verage **S**ensor **V**alues

**SSD** = **S**ite **S**pecific **D**ata, i.e. all the installation programming created and downloaded via EBLWin.

**S/W** = Software, i.e. the EBL512 G3 system program.

The date & time and alarm counter value is stored in the memory of the real time clock, i.e. the value will be retained also after the FDCIE has been powered down.

**Note:** After any restart, a new week average sensor value will be calculated within two minutes for all the analogue smoke detectors. During these two minutes all fire alarms from analogue smoke sensors will be suppressed. Thereafter a new average sensor value will be calculated each week

### 21.1 Safe Shut Down

**Safe shut down of Control Unit** via menu **H8/S6** will save the **SSW** data in a Flash ROM in FT1020G3. Before the first "Safe shut down" of the Control Unit, this memory is empty. After each "Safe shut down" the latest **SSW** data is saved (Safe shut down will not save the week average sensor values).

When FT1020G3 is powered up, a restart takes place and the RAM (working memory) will read the **SSW** data saved in the Flash memory .

### 21.2 Restart Table

Table 18 below describes the different reset alternatives and how the data is affected.

Table 18 Data affected by restart

Action	Data Deleted	Data not Deleted	Restart Code
Power down and then power up again. (both mains and batteries disconnected)	SSW, FFD, WASV	SSD, S/W, SSW <sup>37</sup> Passwords	00 (+ 50)
Via menu H8/S5 Safe shut down of Control Unit.	FFD, WASV	SSD, S/W, SSW	00 (+50) 03 (+53)
Via RESET button on Main board 5012. If this reset is done in the middle of a process, also the SSW might be deleted.	FFD, WASV	SSD, S/W, SSW	00
Via RESET button on MMI board		SSD, S/W, SSW FFD, WASV	50
Reset command via EBLWin or TLON Manager.	FFD, WASV	SSD, S/W, SSW	03 (+53)
Automatically after download of Site Specific Data (SSD) via EBLWin.	FFD, WASV	SSD, S/W, SSW	25
Automatically after download of S/W via EBLWin. The old S/W will be deleted.	FFD, WASV, passwords	SSD, S/W, SSW	03 (+53)
Automatically due to trying to use auto boot mode with an MMI board that doesn't support auto boot mode	FFD, WASV	SSD, S/W, SSW	15

<sup>37</sup> SSW previously saved with safe shut down is not deleted.

Automatically (by the S/W itself) S/W watchdog.	FFD, WASV	SSD, S/W, SSW	13
Automatically due to external disturbance.	FFD, WASV	SSD, S/W, SSW	01, 02 alt. 04-12

**Note:** During a restart, the fault output (relay) for the Fault TX will be "activated" for few seconds, the supervised 24 V<sub>DC</sub> outputs S0-S3 will not be supervised and S0-S3 programmed as normally high will be low for few seconds.

### 21.2.1 Explanation of Restart Codes

- Code 00 displays after manual power on/off or S/W download.
- Code 03 will display after a normal restart.
- Code 13 is always followed by an address, to be noted.
- Code 25 displays after download of SSD and automatic restart.
- Code 50 & 53 will display only if the FDCIE has an MMI board.

**Note:** Code 00 – 49 = Main board restart. Some data might be lost, see above.  
Code 50 – 99 = MMI board restart. No data is lost.

### 21.3 During Restart

During "restart", no fire alarms will be activated and the following is shown on the display:



And after few seconds (the control panel starts the normal restart procedures else see Memory fault below):

Booting.....

A fault will be generated, the buzzer will sound and the following text message will be shown in the display:

FAULT: Restart Control Unit nn, code xx,  
address yyyyyy

Regarding code **xx** and address **yyyyyy**, see Table 18 above.

This fault is also indicated by LEDs **Routing equipment** "Fault TX activated" and **Fault / Disablements** "General fault".

After the fault is acknowledged (via menu H6 or EBLWin), the LEDs will be turned OFF, if no other faults exist in the system.

After any restart, if any units were disabled before restart, an individual disablement for these units should be done.

### 21.3.1 Memory fault

In case of a fault in the Main board S/W (system program) or the MMI board S/W, the following fault message will be shown:

FAULT: Checksum system program, Control Unit xx

(Main board software.)

FAULT: Checksum MMI program, Control Unit xx

(MMI board software.)

FAULT: No connection with MMI board. Control Unit xx

(Not shown in the display, only via EBLWin, Gateway or via another unit in the system).

No contact with Main board

This is also indicated by LED "System fault" and the buzzer sounds steady (continuous). The Fault TX output is "activated".

A new download of the S/W (system programs) is required and/or the Main board and/or the MMI board have to be replaced.

**Note:** After **SSD download**, the following messages may be shown:

Checksum fault in downloaded data.

Control unit will now restart.

After restart:

FAULT: Restart Control Unit nn, code xx,  
address yyyyyyyyyy

FAULT: Site specific data (SSD), control unit xx

This means that the SSD has **not** been successfully downloaded. A new SSD download has to be performed.

## 22 Perform Monthly Test (H1)

The FT1020G3 and its associated equipment in a building must be tested on a regular basis, please refer to the Australian Maintenance standard AS1851 for details regarding monthly, quarterly and annual test.

In test mode, only the alarm points are tested, i.e. no outputs (no OWS or sounders) will be activated during the test. (Alarm devices can be tested via menu H8/S4.)

When a real fire alarm is activated by an alarm point not in test mode, the normal fire alarm functions will be activated, i.e. fire alarm presentation, outputs (sounders or OWS), routing equipment (Fire Brigade TX) will be activated, etc.

**Note:** If FT1020G3 door is left open, the output(s) for external strobe or alarm bell might be disabled (if set in EBLWin).

See also chapter "The information area priority order", page 21.

See also chapter "Perform ZONE TEST (Test mode) (H7)", page 149

Action	Text in display	Comments
"Menu" Log on to FT1020G3		According to Section 6.2, page 42.
Menu H1, press "↵"	<b>H1 Perform monthly test</b>	
"↵"	Check that all LEDs light up! Press ↵	
"↵"	[All dots are visible]	The buzzer (in the C.U.) sounds and all dots in the display are shown. All LEDs light up, including LEDs in units connected via I/O Matrix circuit modules.
"↵"	Zones to be set in test mode: ??? ??? ??? ??? Start test: ↵	Up to 4 zones can be set in test mode
Write zone no, (e.g. 001, 002, 003, 004)	Zones to be set in test mode 001 002 003 004	Press "↵" to start the test mode.
"↵"	Zones in test mode: 001 002 003 004 End test: ↵	LED "Test mode" (L8) will light up. Perform the tests.

The zone(s) will **remain in test mode until the test mode is terminated**. The test mode is terminated in this menu or automatically one hour after the latest alarm test.

You will be automatically logged out 15 minutes after the latest "action" (using any of the keys) but the zone(s) will **remain in test mode until the test mode is terminated**, see above.

Perform the test as quickly as possible, since the output(s) for routing equipment (Fire Brigade TX) are disabled (also the parts of the zones in test mode, not visible for the test personnel, are disabled).

In order to shorten the testing time, any time delay for the detectors / zones in test mode will be "disabled" i.e. fire alarm will be detected faster than normal conditions.

In the tested alarm point, the built-in LED will illuminate and the LEDs "Fire" in the FDCIE will illuminate for approx. 10 seconds, then the alarm point will be automatically reset. There will be a test mode alarm indication in the FDCIE display.

A detector in test mode can't generate a fault.

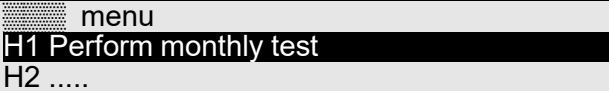
After 15 minutes or "ESC" and "Escape menu"	Zone 001 in test mode Zone 002 in test mode Zone 003 in test mode Zone 004 in test mode  (Note: See chapter "Information Area Priority Order", page 21 regarding priority order.)	You are logged out but the zone(s) are still in test mode.
"Menu" Log in (see above), select menu H1, step down to this view.	Zones in test mode: 001 002 003 004 End test: ↵	Press "↵" to end test.
"↵"	Please wait....	
	Test of routing equipment? <b>No</b> Yes	The LED "Test mode" is turned OFF.
Press "↵" (i.e. select "No") to bypass the routing equipment test. If so, the monthly test is completed. The routing equipment test is always carried out from the ASE.		
	Monthly test is completed! Press ↵	
"↵"		Scroll to another menu or press "ESC".

**Note 1:** During the test, the following information will be shown in all other FDCIE displays:  
Zone 001, 002, 003 or 004 in test mode

**Note 2:** If an alarm point e.g. a manual call point is in alarm state when the test mode is terminated, there will be a fire alarm activated.

**Note 3:** When the "Fire door closing" function is used, the fire door will be closed when the detectors controlling the door are tested, in test mode.

## 23 Disable or Re-enable (H2)<sup>38</sup>

A whole zone<sup>39</sup>, one or more alarm points within a zone and/or control outputs can be disabled via menus H2/B1-B2. This function can be used for temporary disablement (e.g. building maintenance, etc).

**Note:** a whole zone can also be disabled by Brooks zone control card 1205 (if used).

If the function Enhanced disablement is enabled (default), disabled alarm points cannot activate Pre-warning, fire alarm and fault.

If this function is not enabled (via EBLWin), disabled alarm points cannot activate Pre-warning and fire alarm but fault can be generated.

Up to 512 zones can be disabled via menu H2/B1.

Up to 200 alarm points (zones / addresses) can be individually disabled via menu H2/B1 (Alarm points disabled via time channels are not limited and must not be counted).

Up to 200 outputs can be individually disabled via menu H2/B2. Disabled output will remain in (or return to) the normal condition for the output respectively. (Collectively disabled outputs via menus H2/B3 – B4 are not limited and must not be counted).

The limits cannot be exceeded, a warning will be shown:

Max. disablements reached!  
Disablement not performed.

**Don't forget to re-enable** (via menus H2/B1-B2) or use automatic re-enablement for zones and alarm points.

Disablements are listed in menus H4/U1 & U2.

**LED Fault / Disablements** "General disablements" (L10) is indicating one or more disablements in the system.

Disablements are also shown in the display. An example:

Zone 001 disabled  
dd-mm-yyyy hh:mm  
Zone 002 address 01 disabled  
dd-mm-yyyy hh:mm  
.....  
Number of disablements in system: 2

**Note:** See chapter "Information Area Priority Order", page 21, for priority order. Disablements (and faults) are indicated by a 2-sec. beep when you close the CU door.

<sup>38</sup> The word "Disable" or "Re-enable" is used in the Australian convention whilst "Isolate" and "De-Isolate" are used in the New Zealand convention.

<sup>39</sup> When the zone control module is used, a whole zone can be disabled for service purposes.

## 23.1 Zone or Zone Address (H2/B1)

When a whole zone is disabled, all alarm points within the zone are disabled. Alarm points can be individually disabled

Action	Text in display	Comments
"Menu" Log on to FT1020G3		According to Section 6.2, page 42.
Scroll to menu H2.	H2 Disable or re-enable	
"↵"	B1 Zone or Zone/Address B2 Output B3 Output type B4 Alarm devices B5 Routing equipment B6 Alert annunciation function  Escape menu	- Via <b>menu B1</b> , a Zone or an alarm point (Zone / Address) can be disabled. - A time for automatic re-enablement can be set. - Disabled zones and alarm points are shown in a Re-enable list.
"↵"	Disable [redacted] Zone 000 Automatic re-enable: No  Change type of disablement	Use the soft key "Change type of disablements" to toggle between: <b>Zone 000</b> and <b>Zone 000.address 00</b> .
"Change type of disablements"	Disable [redacted] Zone 000 address 00 Automatic re-enable: No  Change type of disablement	Write the zone number and address. To set an automatic re-enable time press "▼" and "▶". Write the time (default is current time + 3 hours). Press "↵" to disable, which will be indicated with "√" and a beep. The zone will be automatically shown in the Re-enable list
Write the zone number and address (e.g. 003, 01). "▼" "▶" "↵"	Disable [redacted] Zone 003 address 01 √ Automatic re-enable: No Yes, at 17:05 -- Re-enable list (1) ----- Zone 003 address 01 auto. re-enable at 17:05  Change type of disablement	If the specified zone / unit is not existing, it will be indicated with "X" instead of "√" and a beep. Use the soft key "→ " to toggle between <b>Disable</b> and <b>Re-enable list</b> .

<p>"→ "</p>	<p>Disable ----- Zone ___ address __ Automatic re-enable: No</p> <p>■ Re-enable list (1) _____ <b>Zone 003 address 01 autom. re-enable at 17:05</b></p> <p style="text-align: right;">→   Change type of disablement</p>	<p>Select in the Re-enable list "▼" (in this example there is only one item) and press "↓". Re-enabled zone or zone / address will disappear from the list, indicated with a beep.</p>
<p>"↓"</p>	<p>Disable _____ Zone 000 address 00 Automatic re-enable: No</p> <p style="text-align: right;">Change type of disablement</p>	<p>Disable (or Re-enable) another Zone, Zone / Address or press "ESC".</p>
<p>"ESC"</p>	<p><b>B1 Zone or Zone/Address</b> B2 Output B3 Output type B4 Alarm devices B5 Routing equipment B6 Alert annunciation function</p> <p style="text-align: right;">Escape menu</p>	<p>Scroll to another menu or press "ESC" or "Escape menu".</p>

**Note:** The sensor values for disabled analogue smoke detectors in NORMAL mode will not be used for calculation of the week average sensor value, i.e. only the values saved before and after the disablement will be used for this calculation.

## 23.2 Output (H2/B2)

All programmable outputs in the FDCIE and outputs in units connected to the COM loops (**except outputs of type "Alarm device"**) can be individually disabled.

If you try to disable an output of type "Alarm device" it will be treated as if it does not exist, see below.

**Disabled output:** Even if its control expression (trigger condition) is fulfilled (true), the output will not be activated.

Action	Text in display	Comments
"Menu" Log on to FT1020G3		According to Section 6.2, page 42.
Scroll to menu H2.	<b>H2 Disable or re-enable</b>	
"↓"	<b>B1 Zone or Zone/Address</b> B2 Output B3 Output type B4 Alarm devices B5 Routing equipment B6 Alert annunciation function  <b>Escape menu</b>	
Scroll to menu B2.	<b>B2 Output</b>	Via menu B2, a loop unit output, C.U. output S0-S3 / R0-R1 and exp. board 4581 output can be disabled.
"↓"	Disable output Loop unit 000000 output 0  <b>Change type of disablements</b>	Use the soft key "Change type of disablements" to toggle between: <b>Loop unit output</b> <b>Control unit output S</b> <b>Control unit output R</b> <b>Exp. board output</b> Write loop unit technical number and output number and press "↓" to disable, which will be indicated with "√" and a beep. The output will be automatically shown in the Re-enable list
Write loop unit technical number and output number, (e.g. 000001 and 0). "↓"	Disable output Loop unit 000000 output 0 ✓ -- Re-enable list (1) ----- Loop unit 000001 output 0  <b>Change type of disablements</b>	If the specified output does not exist, it will be indicated with "X" instead of "√" and a beep. Use the soft key "→ " to toggle between <b>Disable</b> and <b>Re-enable list</b> .

<p>"→ "</p>	<p>Disable output ----- - Loop unit ___ output _ Automatic re-enable: No ■ Re-enable list (1) _____ <b>Loop unit 000001 output 0</b></p> <p style="text-align: right;">→   Change type of disablement</p>	<p>Select in the Re-enable list with "▼" (in this example there is only one item) and press "↓".</p> <p>Re-enabled output will disappear from the list, indicated with a beep.</p>
<p>"↓"</p>	<p>Disable output _____ Loop unit 000000 output 0</p> <p style="text-align: right;">Change type of disablements</p>	<p>Disable (or Re-enable) another output or press "ESC".</p>
<p>"ESC"</p>	<p>B1 Zone or Zone/Address <b>B2 Output</b> B3 Output type B4 Alarm devices B5 Routing equipment B6 Alert annunciation function</p> <p>Escape menu</p>	<p>Scroll to another menu or press "ESC" or "Escape menu".</p>

## 23.3 Output Type (H2/B3)

Outputs of the same type can be collectively disabled via menu H2/B3 in a selected Control Unit or in all Control Units.

Disabled output will stay in (or return to) the normal condition for the output respectively. Disabled outputs are listed in menu H4/U1.







Action	Text in display	Comments
"Menu" Log on to FT1020G3		According to Section 6.2, page 42.
Scroll to menu H2.	<b>H2 Disable or re-enable</b>	
"↓"	<b>B1 Zone or Zone/Address</b> B2 Output B3 Output type B4 Alarm devices B5 Routing equipment B6 Alert annunciation function  <b>Escape menu</b>	
Scroll to menu B3.	<b>B3 Output type</b>	Via menu B3, outputs of the same type can be collectively disabled in selected control unit or all.
"↓"	Disable output type _____ Control outputs in Control unit 00 <b>All</b>          <b>Change type of disablements</b>	Use the soft key "Change type of disablements" to toggle between: <b>Control</b> <b>Ventilation</b> <b>Extinguishing</b> <b>Interlocking</b> Write control unit no. when required. Press "↓" to disable which will be indicated with "√" and a beep. The "type" will be automatically shown in the Re-enable list
"↓"	Disable output type _____ Control outputs in Control unit 00 <b>All</b> ✓ -- Re-enable list (1) ----- All control outputs    <b>Change type of disablements</b>	Use the soft key "→ " to toggle between <b>Disable</b> and <b>Re-enable</b> list.

<p>"→"</p>	<p>Disable output type ----- Control outputs in Control unit 00 All</p> <p>Re-enable list (1)</p> <p>All control outputs</p> <p>Change type of disablement</p>	<p>Select in the Re-enable list with "▼" (in this example there is only one item) and press "↓".</p> <p>Re-enabled type will disappear from the list, indicated with a beep.</p>
<p>"↓"</p>	<p>Disable output type</p> <p>Control outputs in Control unit 00 All</p> <p>Change type of disablements</p>	<p>Disable (or Re-enable) another type or press "ESC".</p>
<p>"ESC"</p>	<p>B1 Zone or Zone/Address B2 Output B3 Output type B4 Alarm devices B5 Routing equipment B6 Alert annunciation function</p> <p>Escape menu</p>	<p>Scroll to another menu or press "ESC" or "Escape menu".</p>

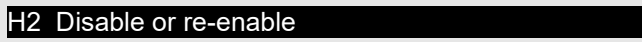
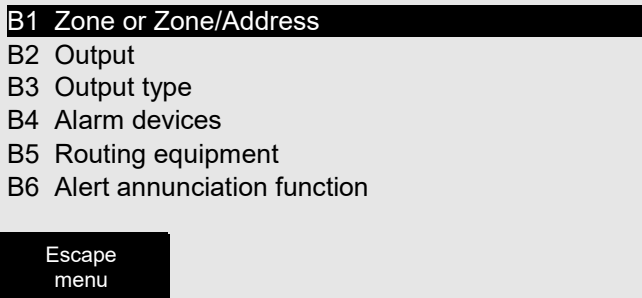
## 23.4 Alarm Devices (H2/B4)

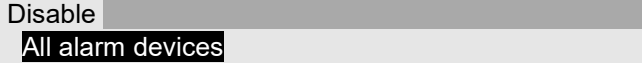
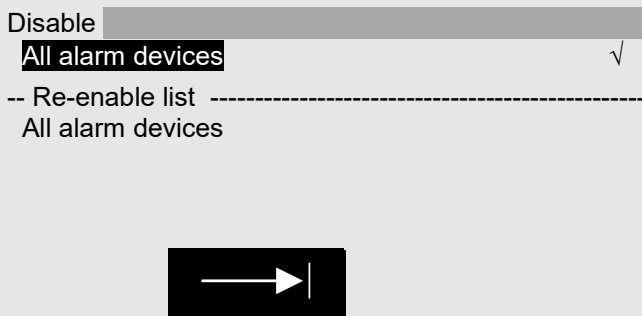
All outputs of type "Alarm device" can be collectively disabled. Disabled output will stay in (or return to) the normal condition for the output respectively.

Disabled outputs are listed in menu H4/U1.

Action	Text in display	Comments
"Menu" Log on to FT1020G3		According to Section 6.2, page 42.
Scroll to menu H2.		
"↓"	 B1 Zone or Zone/Address B2 Output B3 Output type B4 Alarm devices B5 Routing equipment B6 Alert annunciation function  Escape menu	
Scroll to menu B4.		Via menu B4, outputs of type "Alarm device" can be collectively disabled in a selected control unit or all control units.
"↓"		Press "↓" to disable, which will be indicated with "√" and a beep. The "type" will be automatically shown in the Re-enable list
"↓"	 Disable ----- All alarm devices ✓ -- Re-enable list ----- All alarm devices  	Use the soft key "→ " to toggle between <b>Disable</b> and <b>Re-enable list</b> .
"→ "	 Disable ----- All alarm devices Re-enable list ----- All alarm devices  	Press "↓" to re-enable.  Re-enabled type will disappear from the list, indicated with a beep.

<p>"↓"</p>	<p>Disable <b>All alarm devices</b></p>	<p>Disable (or Re-enable) another type or press "ESC".</p>
<p>"ESC"</p>	<p>B1 Zone or Zone/Address          B2 Output          B3 Output type  <b>B4 Alarm device</b>          B5 Routing equipment          B6 Alert annunciation function</p> <p>Escape menu</p>	<p>Scroll to another menu or press "ESC" or "Escape menu".</p>

## 23.5 Routing Equipment / ASE (H2/B5)<sup>40</sup>

Disabled outputs are listed in menu H4/U1.

**Notes:** Outputs for routing equipment (Fire Brigade TX and Fault TX) can be disabled and re-enabled via this menu however disabling and re-enabling is **always carried out via the ASE** itself. Can be useful during installation and commissioning, when only local alarms are required.

Disabled output for routing equipment is indicated by LEDs Fault / Disablements "General disablements" and "Fire Brigade TX".

Disabled output will stay disabled until re-enabled again via this menu.

Action	Text in display	Comments
"Menu" Log on to FT1020G3		According to Section 6.2, page 42.
Scroll to menu H2.	<b>H2 Disable or re-enable</b>	
"↓"	<b>B1 Zone or Zone/Address</b> B2 Output B3 Output type B4 Alarm devices B5 Routing equipment B6 Alert annunciation function  Escape menu	
Scroll to menu B5.	<b>B5 Routing equipment</b>	Via menu B5 the standard outputs (fire and fault) for routing equipment can be disabled.
"↓"	Disable Routing equipment <b>Fire</b> Fault	Use "◀", "▶" to toggle between: <b>Fire</b> <b>Fault</b> Press "↓" to disable, which will be indicated with "√" and a beep. The "type" will be automatically shown in the Re-enable list
"↓"	Disable routing equipment <b>Fire</b> Fault √ -- Disabled routing equipment ----- Fire alarm routing  	Use the soft key "→ " to toggle between <b>Disable</b> and <b>Disabled</b> .

<sup>40</sup> Disable routing equipment from the FDCIE is not permitted, it must be disabled from the ASE itself.

<p>"→"</p>	<p>Disable routing equipment ----- Fire Fault ■ Disabled routing equipment Fire alarm routing</p> <p style="text-align: center;">→</p>	<p>Press "↓" to re-enable.  Re-enabled routing equipment will disappear, indicated with a beep.</p>
<p>"↓"</p>	<p>Disable Routing equipment Fire Fault</p>	<p>Disable or press "ESC".</p>
<p>"ESC"</p>	<p>B1 Zone or Zone/Address B2 Output B3 Output type B4 Alarm devices B5 Routing equipment B6 Alert annunciation function</p> <p>Escape menu</p>	<p>Scroll to another menu or press "ESC" or "Escape menu".</p>

## 23.6 Alert Annunciation (H2/B6)

The **AA** function for alarm points / zones programmed for **Alert Annunciation** (via EBLWin) is normally enabled via a time channel, e.g. enabled daytime (during working hours) and disabled night time.

As an alternative, the **AA** function can be continuously enabled (always on).

The **AA** function can be disabled via this menu (H2/B6) i.e. the **AA** function will be turned off for the alarm points / zones programmed for **Alert Annunciation** although the time channel is "on" or if they are programmed to be continuously enabled.

The **AA** function will remain off until re-enabled again via this menu.

Action	Text in display	Comments
"Menu" Log on to FT1020G3		According to Section 6.2, page 42.
Scroll to menu H2.	H2 Disable or re-enable	
"↓"	B1 Zone or Zone/Address B2 Output B3 Output type B4 Alarm devices B5 Routing equipment B6 Alert annunciation function  Escape menu	
Scroll to menu B6.	B6 Alert annunciation function	Alert Annunciation function can be disabled via menu B6
"↓"	Disable Alert annunciation	Press "↓" to disable, which will be indicated with "√" and a beep. The disablement will be automatically shown in the Re-enable list
"↓"	Disable Alert annunciation √ -- Re-enable list ----- Alert annunciation off  →	Use the soft key "→ " to toggle between <b>Disable</b> and <b>Re-enable</b> .
"→ "	Disable ----- Alert annunciation Re-enable list Alert annunciation off  →	Press "↓" to re-enable. Alert annunciation off will disappear from the list, indicated with a beep.

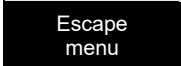
"↓"	Disable  <b>Alert annunciation</b>	Disable or press "ESC".
"ESC"	B1 Zone or Zone/Address B2 Output B3 Output type B4 Alarm devices B5 Routing equipment <b>B6 Alert annunciation function</b>  	Scroll to another menu or press "ESC" or "Escape menu".

## 24 Set Calendar and Clock (H3)

The real time clock (RTC) component has a capacitor as a backup supply. Normally when the Control Unit is turned on for the first time<sup>67</sup>, only the date, time and day of the week required to be set. If required, the clock might be corrected, so that the "time stamps" for fire alarms, faults, etc. will be correct. Upon the completion of the commissioning work, the clock must be checked and corrected if required.

The calendar and clock can be set in any FDCIE for the whole system. Every day (at midnight) the calendar and clock will be synchronised.

**Note 1:** The capacitor can supply the RTC for two days. When the power turned off, it is recommended to check / set the date and time in menu H3.

**Note 2:** If no changes required, press "ESC" instead of "↓" to return to menu H3.

Action	Text in display	Comments
"Menu" Log on to FT1020G3		According to Section 6.2, page 42.
Scroll to menu H3.	<b>H3 Set calendar and clock</b>	
"↓"	DD=MM-YYYY hh:mm Monday Tuesday Wednesday Thursday Friday Saturday Sunday	The date & time shown is valid when this menu is opened. If required, change the date, time and/or weekday (press "▼" or "▲" to select the weekday). <u>The "clock" starts again as from the date, time, etc. shown in the display when you press "↓".</u> If no changes required, press "ESC" instead of "↓".
"↓"	<b>H3 Set calendar and clock</b>	Scroll to another menu or press "ESC".

### 24.1 Daylight Saving Time

The daylight saving is set via EBLWin in the system properties. When set, the time will be automatically changed according to AU or NZ convention. The daylight saving time is set in the firmware as shown below:

**Australian convention:** Forward 1 hour the first Sunday in October, 02:00 → 03:00.  
Backward 1 hour the first Sunday in April, 03:00 → 02:00.

**New Zealand convention:** Forward 1 hour the last Sunday in September, 02:00 → 03:00.  
Backward 1 hour the first Sunday in April, 03:00 → 02:00.

## 25 Present System Status (H4)

### 25.1 Disablement (H4/U1)

This is a dynamic list of all disablements in the system. A disabled zone programmed with address 00 will be displayed as ZZZ-00.

Disablements by time channels are listed in menu H4/U2.

Action	Text in display	Comments
"Menu" Log on to FT1020G3		According to Section 6.2, page 42.
Scroll to menu H4.	<b>H4 Present system status</b>	
"↓"	<b>U1 Disablement</b> U2 Disablement by time channel U3 Open doors U4 Sensor values U5 Sensors activating SERVICE signal U6 Technical warning U7 Event log U8 Information	All disablements in the system, except disablements by time channels, will be shown in menu U1. Press "↓".
"↓"	Zone XXX address XX disabled dd-mm-yyyy hh:mm  Zone XXX is disabled Automatic re-enable hh:mm dd-mm-yyyy hh:mm  Alarm points disabled by time channel in control unit XX dd-mm-yyyy hh:mm ....  Disablement 1 to 3 of 7	If there are no disablements --List is empty-- will be shown. It is a dynamic list in which you can scroll with "▼" or "▲". (Information is shown about disablements by time channels.)
"ESC"	<b>U1 Disablement</b>	Scroll to another menu or press "ESC".

## 25.2 Disablement by Time Channel (H4/U2)

This is a static list of all disablements by time channels in the system. The list has up to four items per page. Indicated by LED "General disablements".

**Note:** All other disablements are listed in menu H4/U1.

Action	Text in display	Comments
"Menu" Log on to FT1020G3		According to Section 6.2, page 42.
Scroll to menu H4.	<b>H4 Present system status</b>	
"↓"	<b>U1 Disablement</b> U2 Disablement by time channel U3 Open doors U4 Sensor values U5 Sensors activating SERVICE signal U6 Technical warning U7 Event log U8 Information	All disablements by time channels, will be shown in menu U2. Press "↓".
Scroll to menu U2.	<b>U2 Disablement by time channel</b>	
"↓"	Zone XXX address XX disabled by time channel Zone XXX address YY disabled by time channel. .... ....  Number of disablements by time channel: 2	If there are no disablements --List is empty-- will be shown. It is a static list (up to 4 items per page) in which you can scroll with "▼" or "▲".
"ESC"	<b>U2 Disablement by time channel</b>	Scroll to another menu or press "ESC".

## 25.3 Open Doors (H4/U3)

If any door in the system is open, the door open symbol  is shown in the symbol area of the display.

See also chapter "Open door" page 56.

This menu is a dynamic list of all open doors in the system.

Action	Text in display	Comments
"Menu" Log on to FT1020G3		According to Section 6.2, page 42.
Scroll to menu H4.	<b>H4 Present system status</b>	
"↓"	<b>U1 Disablement</b> U2 Disablement by time channel U3 Open doors U4 Sensor values U5 Sensors activating SERVICE signal U6 Technical warning U7 Event log U8 Information	All open doors in the system will be shown in menu U3. Press "↓".
Scroll to menu U3.	<b>U3 Open doors</b>	
"↓"	Door open control unit 00 dd-mm-yyyy hh:mm  Door open control unit 01 fire brigade panel 00 dd-mm-yyyy hh:mm .... ....  Open door 1 to 2 of 2	It is a dynamic list in which you can scroll with "▼" or "▲".
"ESC"	<b>U3 Open doors</b>	Scroll to another menu or press "ESC".

## 25.4 Sensor Values (H4/U4)

Action	Text in display	Comments
"Menu" Log on to FT1020G3		According to Section 6.2, page 42.
Scroll to menu H4.	<b>H4 Present system status</b>	
"↓"	<b>U1 Disablement</b> U2 Disablement by time channel U3 Open doors U4 Sensor values U5 Sensors activating SERVICE signal U6 Technical warning U7 Event log U8 Information	
Scroll to menu U4.	<b>U4 Sensor values</b>	
"↓"	Start sensor: 000000	Write the technical number and/or press "↓" to start as from sensor 000001.
"↓"	<p><i>For an Analog multi detector 4300 / 4400 in NORMAL mode:</i> Sensor: 001-01 (technical address 000001) Momentary: XX.X%/m      Weekly: XX.X%/m Perf factor: X.XX%/m      Min: XX.X%/m Algorithm: X-XX      Max: XX.X%/m Momentary: XX°C      Min: XX°C Algorithm: XX      Max: XX°C</p> <p><i>For an Analogue heat detector 3308/3309/4408/4409 in NORMAL mode:</i> Sensor: 001-03 (technical address 000002) Momentary: XX°C      Min: XX°C Algorithm: XX      Max: XX°C</p> <p><i>For an Analogue multi detector 4400 in Advanced mode:</i> Sensor: 001-01 (technical address 000001) Momentary: XX.X%/m      Weekly: XX.X%/m Perf factor: X.XX%/m      Min: XX.X%/m Algorithm: Xxxxxx      Max: XX.X%/m Momentary: XX°C      Min: XX°C Max: XX°C</p> <p><i>For an Analogue multi detector with isolator 4400I in Advanced mode:</i> Sensor: 001-01 (technical address 000001) Momentary: XX.X%/m      Weekly: XX.X%/m Perf factor: X.XX%/m      Min: XX.X%/m Algorithm: Normal      Max: XX.X%/m Momentary: XX°C      Min: XX°C Install date: XXXX-XX-XX      Max: XX°C</p>	If there are no sensors (analogue detectors) when "↓" is pressed, the list view will not open. It is a list in which you can scroll with "▼" or "▲".
"↓"	Start sensor: 000000	Write another technical number and press "↓" or press "ESC".
"ESC"	<b>U4 Sensor values</b>	Scroll to another menu or press "ESC".

## Explanation to the Sensor Values

**Momentary:** Momentary value in this menu will be updated after every detector polling, i.e. approximately every 6 seconds.

**Weekly in NORMAL Mode:** The very first week average sensor value for the 430x and 440x detectors in **NORMAL mode** is calculated within 2½ minutes after SSD download & restart. During these 2½ minutes, no fire alarm can be activated and "Weekly: 00.0%/m" will be shown. The "Weekly" value will thereafter be updated every week.

**Weekly in AVANCED Mode:** For the 440x detectors in **Advanced Mode** the "Weekly" value is 00.0%/m on delivery. It will be updated the first time after 13 minutes. Thereafter, it will be calculated every 13 minutes but then will only be changed downwards if required. After 18 hours it can be changed downwards or upwards and after additional 18 hours (36 hours in total) it can be changed downwards or upwards and it is also saved in the detector's EEPROM, i.e. that value will be used after the power is disconnected from the detector. The "Weekly" value for the 440x detectors in Advanced Mode is also called the "Contamination Compensation Value (CCV)".

**Performance Factor:** The Performance factor can be 0.00 – 2.55.

The Performance factor is normally close to 0.00, which means that the detector is mounted in a "stable" environment. The momentary sensor values during 24 hours do not differ a lot from the week average sensor value.

In an "unstable" environment, the Performance factor will be higher than 0.00. This could for example be the case in a factory (e.g. "dirty" activities during working hours – no or clean activities during the night) and is not a problem as long as there are no nuisance (false) alarms or other problems.

**Algorithm:** shows the algorithm currently in use.

**Install date:** The date is set in the detector when it's powered up by the loop for the first time.

Table 19 Algorithms and abbreviations in NORMAL mode

Algorithm – Normal Mode Detectors 3308/3309/4408/4409, 4301 and 4401	Abbreviation
<b>Normal sensitivity (3%/m) &amp; Normal detection (15 s), Default</b>	<b>N-15</b>
High sensitivity (2.4%/m) & Normal detection (15 s)	H-15
Low sensitivity (3.6%/m) & Normal detection (15 s)	L-15
Normal sensitivity (3%/m) & Slow detection (35 s)	N-35
High sensitivity (2.4%/m) & Slow detection (35 s)	H-35
Low sensitivity (3.6%/m) & Slow detection (35 s)	L-35
Heat algorithm, <b>Class A1, Default</b>	<b>A1</b>
Heat algorithm, Class A2 (S)	A2
Heat algorithm, Class B (S)	B
Decision algorithm	Dec

Table 20 Algorithms in ADVANCED mode

Algorithm – Advanced Mode Detector 4400/4400I	Abbreviation
Normal area, default	Normal
Clean area	Clean
Cooking-Welding area	Welding
Heater area	Heater
Smoke-Steam area	Smoke

## 25.5 Sensors Activating SERVICE Signal (H4/U5)

Menu H4/U5 is a list of the sensor(s) having activated service signal.

When SERVICE signal is generated in the system, the search symbol  is shown in the display's symbol area.

Regarding the SERVICE signal levels, see the EBLWin "Help" instructions, chapter "SERVICE signal".

**Note:** SERVICE signal provides only information to indicate that the sensor is to be replaced soon with a new/clean sensor. After the replacement, the SERVICE signal has to be acknowledged for this sensor, see chapter "Acknowledge SERVICE signal (H8/S2)", page 153.

Action	Text in display	Comments
"Menu" Log on to FT1020G3		According to Section 6.2, page 42.
Scroll to menu H4.	<b>H4 Present system status</b>	
"↓"	<b>U1 Disablement</b> U2 Disablement by time channel U3 Open doors U4 Sensor values U5 Sensors activating SERVICE signal U6 Technical warning U7 Event log U8 Information	
Scroll to menu U5.	<b>U5 Sensors activating SERVICE signal</b>	
"↓"	Sensor, Zone ZZZ address AA needs service technical number xxxxxx 14-03-2013 09:09:15  Sensor, Zone ZZZ address AA needs service technical number xxxxxx 14-03-2013 19:09:35  Number of sensors: 2	If there are no sensors activating service signal, --List is empty-- will be shown. It is a list in which you can scroll with "▼" or "▲".
"ESC"	<b>U5 Sensors activating SERVICE signal</b>	Scroll to another menu or press "ESC".

## 25.6 Technical Warning (H4/U6)

A technical warning is an event that is neither a fire alarm nor a fault. It is information to indicate that an event has occurred as a result of activating a programmable input. The text message, shown in the FDCIE display, is user definable message (up to 40 characters).

One or more activated technical warnings are indicated by  in the display's symbol area.

Action	Text in display	Comments
"Menu" Log on to FT1020G3		According to Section 6.2, page 42.
Scroll to menu H4.	<b>H4 Present system status</b>	
"↓"	<b>U1 Disablement</b> U2 Disablement by time channel U3 Open doors U4 Sensor values U5 Sensors activating SERVICE signal U6 Technical warning U7 Event log U8 Information	
Scroll to menu U6.	<b>U6 Technical warning</b>	
"↓"	<div style="text-align: right;"></div> Technical warning text message 19-02-2023 09:09:15 (User definable text message) 19-02-2023 19:09:35  1 to 2 of 2	If there are no technical warnings, --List is empty-- will be shown. It is a list in which you can scroll with "▼" or "▲".
"ESC"	<b>U6 Technical warning</b>	Scroll to another menu or press "ESC".

**Note:** The technical warnings are normally non-latching, but can via EBLWin be set to "latched".

If a programmable input is activated with a latched technical warning, the technical warning must be reset via this menu.

Technical warnings can be used to activate programmable output.

**Note:** Three new features are provided in software versions  $\geq$  V2.8.x. A technical warning can be set via 3 check boxes for the following options:

1. Show technical warning on the main screen.
2. Technical warning latched.
3. Turn the FDCIE buzzer ON when technical warning is activated.

## 25.7 Event Log (H4/U7)

Three event logs (3 x 999 events) are available:

- Alarm log (alarm events, e.g. fire alarm, fire alarm reset, etc.)
- Interlocking log (only interlocking events)
- General event log (all other type of events)

The origin of the event, e.g. **CU00** (see below), may be originated from **EBLWin**, **EBLWeb** or **Ext#** (External system no. # connected via gateway).

Action	Text in display	Comments
"Menu" Log on to FT1020G3		According to Section 6.2, page 42.
Scroll to menu H4.	<b>H4 Present system status</b>	
"↓"	<b>U1 Disablement</b> U2 Disablement by time channel U3 Open doors U4 Sensor values U5 Sensors activating SERVICE signal U6 Technical warning U7 Event log U8 Information	
Scroll to menu U7.	<b>U7 Event log</b>	
"↓"	Select event log: <b>Alarm log</b> Interlocking log General event log	Use "▼" or "▲" to select a log. (e.g. the "Alarm log".)
"↓"	Command: Reset all alarms 19-02-2023 09:25:30 CU00  FIRE ALARM zone 123 address 45 19-02-2023 09:45:15 CU00  FIRE ALARM zone 123 address 46 19-02-2023 09:55:01 CU00  Event 15 to 13 of 21	If there are no events, -- List is empty-- will be shown. The list is dynamic in which you can scroll with "▼" or "▲". The most recent event is on top of the list.
"ESC"	<b>U6 Event log</b>	Scroll to another menu or press "ESC".

## 25.8 Information (H4/U8)

This menu can be used to show the following information for the specific Control Unit you currently use:

**Main board version:** The S/W (software / firmware / system program) version downloaded to the Main board.

**MMI board version:** The S/W (software / firmware / system program) version downloaded to the MMI board.

**Alarm counter:** The alarm counter is increased with "1" every time the FDCIE enters a real "fire alarm condition" (i.e. fire alarm indication in the display, LEDs "Fire" are illuminating and the FDCIE buzzer is sounding). Alarms from zones in test mode will not be counted. The alarm counter starts at 000 and goes to 999. It can be reset to 000 via EBLWin level 1 access (Control unit menu "Reset alarm counter..."). The value will be retained also after the FDCIE has been completely powered off. During synchronization, the alarm counter will also be synchronized, so that the highest value is stored in each control unit in the system.

**Max. number of allowed alarm points** that can be used in this Control Unit, i.e. 128, 256, 512 or 1020. (Configured number of alarm points). Default number is 512 addresses.

**Serial number:** The manufacturer's serial number (year YY, week WW, plant P, number of the main board NNN) used e.g. when upgrading max. no. of allowed alarm points.

**Control unit number:** 00-29.

Action	Text in display	Comments
"Menu" Log on to FT1020G3		According to Section 6.2, page 42.
Scroll to menu H4.	<b>H4 Present system status</b>	
"↓"	<b>U1 Disablement</b> U2 Disablement by time channel U3 Open doors U4 Sensor values U5 Sensors activating SERVICE signal U6 Technical warning U7 Event log U8 Information	
Scroll to menu U8.	<b>U8 Information</b>	
"↓"	Main board version: 3.6 MMI board version: 3.6 Alarm counter: nnn Max number of allowed alarm points: xxx Serial number: xxxxxxx Control unit: NN	
"ESC"	<b>U7 Information</b>	Scroll to another menu or press "ESC".

## 26 Service (H5)

---

Menu H5 can be used to display certain information to help during commissioning an installation or maintaining existing system (e.g. when you power up and when you are programming a Control Unit / system).

Only authorised personnel have access to menu H5 and a password for level 3A (Service technician) is required.

Some tasks for service technician can be carried out via a PC and EBLWin:

- Download / backup (upload) the Site Specific Data (SSD)
- Create and download software (S/W), settings, configurations, Control Unit and system properties.
- Create and download the user definable text messages (alarm texts) shown in the display of the Control Unit and Display units (if used).

**Note:** To be able to log on to an FT1020G3 FDCIE via a PC using EBLWin, the PC has to be provided with an EBLWin key (5094). This USB device has a number (a key) required for the log on.

Via a PC and **TLON Manager** you can create and download (install) the TLON network configuration (TLON project).

## 26.1 Calibration of Supervised Outputs (H5/A1)

Supervised (monitored) outputs:

- Voltage outputs (S0-S3) in each Control Unit.
- Voltage outputs (VO0-VO1) in the COM loop output unit 3364.
- The voltage outputs (0-2) on the I/O exp. Boards 4583.

When all alarm devices (OWS, sounders, etc.) are connected, including required end-of-line devices and when the SSD is downloaded, a **calibration** of the supervised outputs must be performed.

**Function:** If the actual value at any time differs from the calibrated value  $\pm$  a small tolerance or if the calibrated value is outside the calibration range, a fault will be generated.

Action	Text in display	Comments
"Menu" Log on to FT1020G3		According to Section 6.2, page 42.
Scroll to menu H5.	<b>H5 Service</b>	
"↓"	<b>A1 Calibration of supervised outputs</b> A2 Sensitive fault detection mode A3 Service mode for COM-loop A4 Display current consumption in control unit A5 Display current consumption on COM-loop A6 Display statistics for communication A7 Activate address setting mode for DU A8 Setup wireless detectors A9 SSD information	
"↓"	Start calibration of supervised outputs (press ↓)	
"↓"	Calibration completed successfully	√
"ESC"	<b>A1 Calibration of supervised outputs</b>	Calibration is ready. Scroll to another menu or press "ESC".

**Note:** After the calibration is completed, it is recommended to do a "Safe shut down of Control Unit (H8/S5)" page 157. This will save the SSW data (e.g. the calibration values) in a Flash Memory .

### END-OF-LINE Devices

**Control unit outputs S0-S3, programmed as supervised (1-50K $\Omega$ ):** One end-of-line resistor (33K $\Omega$ ) in the last unit or one resistor (33K $\Omega$ ) in up to five units.

**3364 outputs (VO0-VO1):** One end-of-line capacitor (470 nF) in the last unit or one capacitor (470 nF) in up to five units.

## 26.2 Sensitive Fault Detection Mode (H5/A2)

During commissioning, the "Sensitive fault detection mode" can be used to enable the commissioning personnel to detect the faults faster than normal mode. The time delay for each fault will then be reduced, i.e. you may find some faults now instead of later.

When the "Sensitive fault detection mode" is turned on, it is indicated by the LED **Routing equipment** "Fault TX activated", "Fault" output for routing equipment is "activated" and the search symbol  appears in the symbol area of the display.

**Note:** Don't forget to turn off this mode after the commissioning.

Action	Text in display	Comments
"Menu" Log on to FT1020G3		According to Section 6.2, page 42.
Scroll to menu H5.	<b>H5 Service</b>	
"↓"	<b>A1 Calibration of supervised output</b> A2 Sensitive fault detection mode A3 Service mode for COM-loop A4 Display current consumption in control unit A5 Display current consumption on COM-loop A6 Display statistics for communication A7 Activate address setting mode for DU A8 Setup wireless detectors A9 SSD information	
Scroll to menu A2.	<b>A2 Sensitive fault detection mode</b>	
"↓"	Sensitive fault detection mode is not active Press ↓ to activate	
"↓"	 Sensitive fault detection mode was activated Press ↓ to deactivate	
"↓"	Sensitive fault detection mode is not active Press ↓ to activate	
"ESC"	<b>A2 Sensitive fault detection mode</b>	Scroll to another menu or press "ESC".

## 26.3 Service Mode for COM-Loop (H5/A3)

This mode can be used when commissioning an installation and during maintenance. The COM loop communication (polling) will be turned off but 24V<sub>DC</sub> still exist on the loop in the A-direction, the B-direction **or** in both directions at the same time.

A voltmeter can be used to check the voltage / voltage drop on different segments on the loop or to find a single break on the loop. (Since there is voltage on the loop, short circuit isolators will work normally).

It is also recommended to do this check when the power of FT1020G3 is supplied via the backup battery only, since the battery voltage can be different (compared with the power supply voltage) due to the battery condition, backup duration, etc.

The "Service mode for COM-loop" is indicated by LED **Fault / Disablements** "General disablements" and the symbol  flashing.

If the user stays in this menu window, without doing any actions, there will be a timeout after 1 hour, and the user is logged off. If the user logs off this menu, the "Service mode for COM-loop" will be terminated automatically.

**Note:** If short-circuit is detected when a COM loop is in service mode, the loop will be disabled and a fault message will be displayed.

**FAULT: Short-circuit SCI A <-> SCI B,  
loop x, Control Unit xx**

...independent of where the short circuit is situated on the loop.

Action	Text in display	Comments
"Menu" Log on to FT1020G3		According to Section 6.2, page 42.
Scroll to menu H5.	<b>H5 Service</b>	
"↓"	<b>A1 Calibration of supervised output</b> A2 Sensitive fault detection mode A3 Service mode for COM-loop A4 Display current consumption in control unit A5 Display current consumption on COM-loop A6 Display statistics for communication A7 Activate address setting mode for DU A8 Setup wireless detectors A9 SSD information	
Scroll to menu A3.	<b>A3 Service mode for COM-loop</b>	
"↓"	Service mode for loop: <b>0</b> CU: 00 <b>A Direction</b> B Direction Both	Write loop and control unit numbers. Use "▼" or "▲" to scroll to the required direction(s) and press "↓".
"↓"	Service mode control unit 00 COM-loop 0 Supplied from A-direction only	When you leave this menu by pressing "ESC" or "↓" the service mode will be terminated, i.e. the communication will return to the normal mode.
"ESC" or "↓"	<b>A3 Service mode for COM-loop</b>	Scroll to another menu or press "ESC".



Follow the below instructions to view the control panel current consumption.

Action	Text in display	Comments
"Menu" Log on to FT1020G3		According to Section 6.2, page 42.
Scroll to menu H5.	<b>H5 Service</b>	
"↓"	<b>A1 Calibration of supervised output</b> A2 Sensitive fault detection mode A3 Service mode for COM-loop A4 Display current consumption in Control Unit A5 Display current consumption on COM-loop A6 Display statistics for communication A7 Activate address setting mode for DU A8 Setup wireless detectors A9 SSD information	
Scroll to menu A4.	<b>A4 Display current consumption in control unit</b>	
"↓"	Select control unit : 00 (press ←)	Write control unit number and press "↓".
"↓"	Please wait.....	
	No reply from control unit.....	If the control unit is not existing or not responding.
	<b>Power supply</b> (Control Unit 00) Voltage: xx.xx V Earth voltage: xx.xx V Current from power supply: xxx mA <b>Battery</b> Voltage: xx.xx V Charging current: x mA Temperature xx°C Resistance in battery circuit: xxxxx mΩ	Information is automatically updated every 5 second.
"↓" or "ESC"	<b>A4 Display current consumption in unit</b>	Scroll to another menu or press "ESC".

**Note:** If you get "No reply from control unit....." the control unit doesn't exist or doesn't answer

## 26.5 Display Current Consumption on COM-loop (H5/A5)

The current consumption (an average value) for each COM loop can be displayed.

Action	Text in display	Comments
"Menu" Log on to FT1020G3		According to Section 6.2, page 42.
Scroll to menu H5.	<b>H5 Service</b>	
"↓"	A1 Calibration of supervised output A2 Sensitive fault detection mode A3 Service mode for COM-loop A4 Display current consumption in Control Unit A5 Display current consumption on COM-loop A6 Display statistics for communication A7 Activate address setting mode for DU A8 Setup wireless detectors A9 SSD information	
Scroll to menu A5.	<b>A5 Display current consumption on COM-loop</b>	
"↓"	Display current consumption on COM-loop: 0 control unit: 00 (press ↵)	Write loop number and control unit number and press "↓".
"↓"	Please wait.....	
	No reply from control unit.....	If the control unit is existing or doesn't respond.
	Current consumption and resistance on COM-loop: Control unit 00 COM-loop 0 xxxx mA ≤ xxx Ω SUB-loop 0 xxxx mA ≤ xxx Ω	The current consumption accuracy is ±5 mA. Information is automatically updated every 5 seconds
"↓" or "ESC"	<b>A5 Display current consumption on COM-loop</b>	Scroll to another menu or press "ESC".

**Note 1:** No or very small current consumption (< 10 mA) cannot be presented correctly / precisely since the accuracy is ±5 mA.

**Note 2:** If you get "No reply from control unit....." the control unit don't exist or don't answer.

## 26.6 Display Statistics for Communication (H5/A6)

The statistics can be used during commissioning, service, etc.

**Number of pollings** is the number of pollings / "questions" sent out by the Control Unit to all the units connected on the COM loop.

**Parity fault** is the received number of parity faults and % (faults in relation to pollings).  
**Number of bit faults** is the received number of bit faults and % (faults in relation to pollings).

**No answer** is the received number of answer faults / no answers and % (faults in relation to pollings).

**Bit length fault** is the received number of bit length faults and % bit length faults in relation to the pollings.

The number of Parity faults, number of bit faults, no answer and Bit length faults should be normally "0" or as close to "0" as possible. If not, there are some communication problems that have to be investigated. Check the COM loop, connections and the loop units.

All values are set to "0" after restart and/or after re-connection of COM loop (via menu H8/S1).

Action	Text in display	Comments
"Menu" Log on to FT1020G3		According to Section 6.2, page 42.
Scroll to menu H5.	<b>H5 Service</b>	
"↓"	<b>A1 Calibration of supervised output</b> A2 Sensitive fault detection mode A3 Service mode for COM-loop A4 Display current consumption in Control Unit A5 Display current consumption on COM-loop A6 Display statistics for communication A7 Activate address setting mode for DU A8 Setup wireless detectors A9 SSD information	
Scroll to menu A6	<b>A6 Display statistics for communication</b>	
"↓"	Display statistics for COM-loop: 0 control unit: 00	Write loop number and control unit number and press "↓".
"↓"	Please wait.....	
	No reply from control unit.....	If the control unit is not existing or doesn't respond.
	Number of pollings: nnnnnnn Parity fault: 000000 00.0% Number of bits fault: 000000 00.0% No answer: 000000 00.0% Bit length fault: 000000 00.0%	<b>Note:</b> The values are not live updated.
"↓" or "ESC"	<b>A6 Display statistics for communication</b>	Scroll to another menu or press "ESC".

The information is automatically updated every 5 seconds

## 26.7 Activate Address Setting Mode for DU (H5/A7)

This function can be used by commissioning / service technicians to activate the address setting mode in the following Display Units connected to the FDCIE:

- External Presentation units
- Alert Annunciation units
- General Control Panel

A specific unit or all units connected to one FDCIE can be activated for address setting.

**Note:** The units should be in operation and in quiescent condition, i.e. the units should have already an address.

Action	Text in display	Comments
"Menu" Log on to FT1020G3		According to Section 6.2, page 42.
Scroll to menu H5.	<b>H5 Service</b>	
"↓"	A1 Calibration of supervised output A2 Sensitive fault detection mode A3 Service mode for COM-loop A4 Display current consumption in Control Unit A5 Display current consumption on COM-loop A6 Display statistics for communication A7 Activate address setting mode for DU A8 Setup wireless detectors A9 SSD information	
Scroll to menu A7	<b>A7 Activate address setting mode for DU</b>	
"↓"	Activate address setting mode for display unit: Control unit: 00, display unit: 00 All	Write control unit number, and the unit's address or press "▶" to select "All" (i.e. all display units on the selected control unit).
"↓"	Address setting mode for display unit 00, control unit 00 activated	The address can now be edited in the display unit (DU) respectively.
"↓" or "ESC"	<b>A7 Activate address setting mode for DU</b>	Scroll to another menu or press "ESC".

## 26.8 Setup wireless detectors (H5/A8)

This function can be used by commissioning / service engineer to set a Base station (4620) for wireless units to one of the following modes:

**Register:** in order to register one or more wireless units 4611/4614 to the Base station

**Unregister:** in order to unregister one or more wireless detectors 4611/4614 from the Base station

**Install:** in order to change the normal communication time from every 2<sup>nd</sup> minute to every 5<sup>th</sup> second, to be used during commissioning, etc.

**Note:** To set the Base station to any of the modes above, the Base station has to be in a "Normal state" i.e. not set to any of the modes. For example, a Base station set to e.g. "Register" mode has to be set back to "Normal state" before it can be set to any other mode.

For more information, see the Brooks wireless technical manual M445.

Action	Text in display	Comments
"Menu" Log on to FT1020G3		According to Section 6.2, page 42.
Scroll to menu H5.	<b>H5 Service</b>	
"↓"	A1 Calibration of supervised output A2 Sensitive fault detection mode A3 Service mode for COM-loop A4 Display current consumption in Control Unit A5 Display current consumption on COM-loop A6 Display statistics for communication A7 Activate address setting mode for DU A8 Setup wireless detectors A9 SSD information	
Scroll to menu A8	<b>A8 Setup wireless detector</b>	
"↓"	Set base station mode Set base station 000000 to one of the following:  Register Unregister Install	Write the technical number for the Base station. Select the required mode. Press "↓". Base station in Register mode is indicated with "√" and a beep. It will be shown in the Base station mode list
E.g.: "000001" "Register"	Set base station mode Set base station 000000 to Register Unregister                   √ Install  -- Base station mode (1) ----- Register, base station 000001  	If the specified Base station doesn't exist, it will be indicated by "X" instead of "√" and a beep. Use the soft key "→ " to toggle between "Set base station mode" and the "Base station mode" list.

<p>"→ "</p>	<p>Set base station mode Set base station -----to Register Unregister Install -- Base station mode (1) ----- Register, base station 000001</p> 	<p>Select a Base station in the list and press "↓" to go from Register mode back to Normal state. The Base station will disappear from the list, indicated with a beep.</p>
<p>"↓"</p>	<p>Set base station mode Set base station -----to Register Unregister Install</p>	<p>The same procedure is valid for the Unregister and Install modes. Press "ESC" to go back to menu "A8".</p>
<p>"ESC".</p>	<p>A8 Setup wireless detector</p>	<p>Scroll to another menu or press "ESC".</p>

**Note:** The base station must be set back to the "Normal state" for the wireless detectors to function normally.

## 26.9 SSD Information (H5/A9)

**SSD name:** as written in the EBLWin dialog box "System Properties" (Name).

**Downloaded:** date and time when the SSD was downloaded. user name for the person who performed the SSD download.

**Computer:** computer name (if programmed) for the PC that was used for the SSD download.

**Domain:** domain (if programmed) for the PC that was used for the SSD download.

**EBLWin key:** the unique number for EBLWin key.

**Convention:** Country specific functions, default EBLWin settings, etc.) is set in conjunction with the installation of EBLWin.

**SSD download count:** Number of times the SSD has been downloaded.

Action	Text in display	Comments
"Menu" Log on to FT1020G3		According to Section 6.2, page 42.
Scroll to menu H5.	<b>H5 Service</b>	
"↓"	A1 Calibration of supervised output A2 Sensitive fault detection mode A3 Service mode for COM-loop A4 Display current consumption in Control unit A5 Display current consumption on COM-loop A6 Display statistics for communication A7 Activate address setting mode for DU A8 Setup wireless detectors A9 SSD information	
Scroll to menu A8	<b>A9 SSD information</b>	
"↓"	SSD name: XXXXXXXXXXXXXXXX Downloaded: dd-mm-yyyy hh:mm User: Nnnnnnn Computer: Ccccccccccccc Domain: Ddddddddddd EBLWin key: 1234567890 Convention: XXX SSD download count: XXX	
"↓" or "ESC"	<b>A9 SSD information</b>	Scroll to another menu or press "ESC".

## 27 FAULT Acknowledge (H6)

For more information of fault indication, etc., refer to chapter "Fault", page 70. See also section "Fault Messages", page 71 where all fault messages are listed.

Refer also to section "Fault Acknowledge", page 87

All the faults and status / action are stored in the event log and can be listed, see chapter "Event log (H4/U7)", page 134.

Up to 300 faults in menu H6 can be listed:

- Not corrected (not serviced) and not acknowledged faults (no status information)
- Not corrected (not serviced) but acknowledged faults (acknowledged)
- Corrected (serviced) but not acknowledged faults (serviced).

The most recent fault is shown on the top of the list

Action	Text in display	Comments
"Menu" Log on to FT1020G3		According to Section 6.2, page 42.
Scroll to menu H6	<b>H6 FAULT Acknowledge</b>	
"↓"	<p><b>FAULT: Low battery capacity, control unit 00</b> dd-mm-yyyy hh:mm</p> <p>FAULT: No reply zone 045 address 06 technical number 000005 Alarm text for 045-06 (user definable) dd-mm-yyyy hh:mm /Serviced</p> <p>FAULT: No reply zone 021 address 05 technical number 000114 Alarm text for 021-05 (user definable) dd-mm-yyyy hh:mm /Acknowledged</p> <p>Fault 1/3 is selected</p> <p>Previous page      Next page</p>	<p>If there are no faults --List is empty-- will be shown. It is a dynamic list in which you can scroll with "▼" or "▲".</p> <p>To acknowledge a fault, select it and press "↓". The selected fault has a boarder around it.</p>
"↓"	<p><b>FAULT: Low battery capacity, control unit 00</b> dd-mm-yyyy hh:mm /Acknowledged</p> <p>FAULT: No reply zone 045 address 06 technical number 000005 Alarm text for 045-06 (user definable) dd-mm-yyyy hh:mm /Serviced</p> <p>FAULT: No reply zone 021 address 05 technical number 000114 Alarm text for 021-05 (user definable) dd-mm-yyyy hh:mm /Acknowledged</p> <p>Fault 1/3 is selected</p> <p>Previous page      Next page</p>	<p>A corrected / serviced fault that is acknowledged will disappear from this list.</p>
"ESC"	<b>H6 FAULT Acknowledge</b>	Scroll to another menu or press "ESC".

## 28 Perform Zone Test (Test mode) (H7)

Zones can be tested via menu H1, refer to the maintenance standard AS1851 for more information in regards to the requirements. However, it is also possible to perform a zone test via menu (H7). Up to 100 zones can be set in test mode.

In test mode, only the alarm points are tested, i.e. no outputs (e.g. OWS or sounders) will be activated during the test (Alarm devices can be tested via menu H8/S4 and any output via menu H8/S8 or via EBLWin (when you are logged on).

If a real fire alarm is activated by an alarm point not in test mode, the normal fire alarm functions will be activated, i.e. fire alarm presentation, outputs (OWS or sounders) activated, routing equipment (Fire Brigade TX) activated, etc.

See also chapter "Information Area Priority Order", page 21.

One or more zones in test mode are indicated by the LED "Test mode" (L8). The green polling LED in the 440x detectors will be turned off in test mode.

The zones are set in test mode one a time and the test mode has to be terminated for each zone one by one.

Action	Text in display	Comments
"Menu" Log on to FT1020G3		According to Section 6.2, page 42.
Scroll to menu H7.	<b>H7 Perform ZONE TEST</b>	
	Press the soft key <b>Single/Multiple</b> to toggle between: -Zone 000 -From zone 000 to zone 000	
"↓"	■ Set in test mode [redacted] Zone 000	
Write the zone number (e.g. 001). "↓"	■ Set in test mode [redacted] ✓ Zone 001 -- End test mode ----- Zone 001	Press "↓" to start the test mode. Indicated by "√" and a beep. If the specified zone is not existing, it will be indicated with "X" instead of "√" and a beep.  All zones set in test mode will be shown in the "End test mode" list. Use the soft key "→ " to toggle between <b>Set in test mode</b> and <b>End test mode list</b> .

<p>"→"</p>	<p>-- Set in test mode -----          Zone _ _ _ ✓          End test mode [grey bar]          Zone 001 [black bar]</p> <p>[right arrow]</p>	<p>After the testing, select a zone in the "End test mode" list and press "↓". The test mode will be terminated for all zones.</p>
<p>The zone(s) will <b>stay in test mode until the test mode is terminated</b>. The test mode is terminated in this menu or automatically after one hour.</p> <p>You will be automatically logged out 15 minutes after the latest "action" (using of any key) but the zone(s) will <b>stay in test mode until the test mode is terminated</b>, see above.</p> <p>Perform the test as quickly as possible, since the output(s) for routing equipment (fire brigade tx) are disabled (also the parts of the zones in test mode, not visible for the test personnel, are disabled).</p> <p>In order to shorten the testing time, any time delay for the detectors / zones in test mode will be "disabled", i.e. fire alarm will be detected faster than normal.</p> <p>In the tested alarm point, the LED will light up, and the LEDs "Fire" (L1) in the FDCIE will light up for approx. 10 seconds, then the alarm point will be automatically reset.</p> <p>An alarm point in test mode will <u>not</u> be able to generate a fault. An alarm point "in alarm" when the test mode is terminated will activate a normal fire alarm.</p>		
<p>"↓" for each zone to end the test mode.</p>	<p>Set in test mode [grey bar]          Zone 000</p>	<p>No zones in test mode. Set new zones in test mode or press "ESC".</p>
<p>"ESC"</p>	<p>H7 Perform ZONE TEST [black bar]</p>	<p>The LED "Test mode" (L8) is turned OFF. If more zones are to be tested, continue as above. If not, scroll to another menu or press "ESC".</p>

**Note 1:** During the test, the following information will be shown in all other FDCIE displays:  
 Zone 001 in test mode  
 Zone 002 in test mode Etc.

**Note 2:** If an alarm point (e.g. a manual call point) is in alarm state when the test mode is terminated, a fire alarm will be activated.

**Note 3:** When the "Fire door closing" function is used, the fire door will be closed when the detectors controlling the door are tested in test mode.

## 29 Maintenance (H8)

Only authorised personnel have access to menu H8 and password for level 3A (Service technician) is required.

### 29.1 Disconnect / Reconnect Loop / Zone Line Input (H8/S1)



Before physical connection / disconnection of loop units, etc. the loop (or zone line input) must be disconnected (voltage free) in order to avoid any damage to the units or the FDCIE, i.e. there will be no voltage on the "loop" or the zone line input.

Zone Line Input comprises 8 zones Expansion Board 4580 in the Control Unit or an Addressable I/O unit 4461 connected on a COM loop.

One or more disconnected "loops" are indicated by LED **Fault / Disablements** "General disablements" (L10), the symbol  is flashing and listed in menu H4/U1.

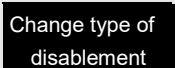
**Note:** When you re-connect a COM loop all the statistics shown in menu H5/A6 will be erased and set to "0".

Action	Text in display	Comments
"Menu" Log on to FT1020G3		According to Section 6.2, page 42.
Scroll to menu H8.	<b>H8 Maintenance</b>	
"↓"	<b>S1 Dis- / Re-connect loop / zone line input</b> S2 Acknowledge SERVICE signal S3 Clear weekly average S4 Test of alarm devices S5 Safe shut down of control unit S6 Activate address in alarm mode S7 Synchronize the control units S8 Activate / Reset outputs	Via menu S1 a COM loop, a zone line input on expansion board and an addressable zone interface input can be Disconnected / Re-connected
"↓"	Disconnect  control unit 00  	Use the soft key "Change type of disablements" to toggle between: <b>COM loop</b> <b>SUB-loop</b> <b>Zone line input</b> (exp. board) <b>Zone interface input</b> (loop unit) to disconnect, which will be indicated with "√" and a beep.

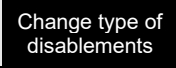
<p>Write COM loop number and control unit number. "↓"</p>	<p>Disconnect [redacted] COM loop 0, control unit 00 ✓</p> <p>-- Re-connect list (1) ----- COM loop 0, control unit 00</p> <p style="text-align: center;"></p>	<p>The loop will be automatically shown in the Re-connect list. If the specified loop etc. is not exist, it will be indicated with "X" instead of "✓" and a beep. Use the soft key "→ " to toggle between the <b>Disconnect</b> and <b>Re-connect</b> list.</p>
<p>"→ "</p>	<p>-- Disconnect ----- COM loop _, control unit _ _</p> <p>Re-connect list (1) [redacted] COM loop 0, control unit 0</p> <p style="text-align: center;"></p>	<p>Select in the Re-connect list with "▼" (in this example, there is only one item) and press "↓".</p> <p>Re- connected loop will disappear from the list, indicated with a beep.</p>
	<p>Disconnect [redacted] COM loop 0, control unit 00</p> <p style="text-align: center;"></p>	<p>Disconnect (or Re-connect) another "loop" or press "ESC".</p>
<p>"ESC"</p>	<p>S1 Dis- / Re-connect loop / zone line input</p>	<p>Scroll to another menu or press "ESC".</p>

## 29.2 Acknowledge SERVICE Signal (H8/S2)

When SERVICE signal is generated in the system, the search symbol  is shown in the display's symbol area. See also chapter "Sensors Activating SERVICE Signal (H4/U5)", page 132.

Sensor = analogue smoke detector.

Only 430x, 4400 and 4401 sensors in NORMAL mode can be acknowledged. When service signal from such a sensor (smoke detector) is acknowledged, the sensor is given a default week average sensor value (same as for a new / clean sensor, i.e. "1" = 0.1 %/m). **First** replace the sensor and **then** acknowledge the service signal **as soon as possible**. The first week average sensor value after acknowledge will be calculated within one hour, then each week.

Sensors 4400, 4401 set in advanced mode do not have to be acknowledged if they are replaced after generating service signal. They will be automatically reset.

**Note:** If a sensor 430x and 440x in NORMAL mode is replaced without having generated service signal, it has to be reset (clear) to the default week average sensor value via menu H8/S3, page 155.

Action	Text in display	Comments
"Menu" Log on to FT1020G3		According to Section 6.2, page 42.
Scroll to menu H8.	<b>H8 Maintenance</b>	
"↓"	S1 Dis- / Re-connect loop / zone line input S2 Acknowledge SERVICE signal S3 Clear weekly average S4 Test of alarm devices S5 Safe shut down of control unit S6 Activate address in alarm mode S7 Synchronize the control units S8 Activate / Reset outputs	
Scroll to menu S2.	<b>S2 Acknowledge SERVICE signal</b>	
"↓"	Sensor, Zone ZZZ address AA needs service technical address xxxxxx 14-03-2023 09:09:15  Sensor, Zone XXX address AA needs service technical address xxxxxx 14-03-2023 19:09:35  Sensor 1/2 is selected  Previous page   Next page	If there are no sensors -- List is empty-- is shown. This is a dynamic list in which you can scroll. The most recent service signal / sensor is shown on top of the list. Use "▼" or "▲" to select a sensor (the selected sensor has a border). Press "↓" to acknowledge the sensor.

<p>"↓"</p>	<p>Sensor, Zone XXX address AA needs service technical address xxxxxx 20-02-2013 09:09:35</p> <p>Sensor 1/1 is selected</p> <p>Previous page   Next page</p>	<p>The acknowledged sensor disappears from the list. Continue as above or press "ESC".</p>
<p>"ESC"</p>	<p>S2 Acknowledge SERVICE signal</p>	<p>Scroll to another menu or press "ESC".</p>

The "Service symbol"  and the "Service message" will be turned off when all sensors have been acknowledged.

## 29.3 Clear Weekly Average (H8/S3)

Valid only for 430x, 4400 and 4401 sensors in **NORMAL mode**.

If a sensor (analogue smoke detector) is replaced without having generated SERVICE signal, its week average sensor value has to be cleared and set to the default value (i.e. "1" = 0.1 %/m), otherwise the new / clean sensor will inherit the old sensor's value. It is possible to clear the week average sensor value for each sensor individually via this menu.

**Note:** First, replace the sensor and then clear the week average value as soon as possible. Authorised service personnel only, must do this. Using the function incorrectly may cause nuisance fire alarms.

The first week average sensor value (after clearing) will be calculated within one hour, then each week.

Action	Text in display	Comments
"Menu" Log on to FT1020G3		According to Section 6.2, page 42.
Scroll to menu H8.	<b>H8 Maintenance</b>	
"↓"	S1 Dis- / Re-connect loop / zone line input S2 Acknowledge SERVICE signal S3 Clear weekly average S4 Test of alarm devices S5 Safe shut down of control unit S6 Activate address in alarm mode S7 Synchronize the control units S8 Activate / Reset outputs	
Scroll to menu S3.	<b>S3 Clear weekly average</b>	
"↓"	Clear weekly average zone: 000 address: 00 (press ←)	Write the required zone and address and press "↓".
Write the zone and address numbers, (e.g. 001 and 01). "↓"	Weekly average zone 001 address 01 cleared	
"ESC"	<b>S3 Clear weekly average</b>	Continue as above or scroll to another menu or press "ESC".

## 29.4 Test of Alarm Devices (H8/S4)

The programmable outputs of type "Alarm device" can be collectively activated via this menu (H8/S4), which allows for the alarm devices to be tested. This procedure includes Addressable sounder base 3379, wireless detector 4611, all visual alarm devices 4480, 4481, 4482, 4487 and OWS. The tone with the highest priority level type "alarm devices" will be automatically selected.

The test cannot be started if a fire alarm in the system is already active.

One or all Control Units can be selected. When the test starts, the alarm devices will sound continuously (steady) for approx. 5 seconds, be silent for approx. 25 seconds, sound for approx. 5 seconds and so on<sup>41</sup>.

**Note:** Disabled and silenced alarm devices will also be tested and will sound during the test.

The test will continue for one hour if not terminated via this menu (H8/S4) or if a fire alarm is activated in the system. After one hour, when the test mode is terminated, a message is shown in the General event log (menu H4/U7).

Action	Text in display	Comments
"Menu" Log on to FT1020G3		According to Section 6.2, page 42.
Scroll to menu H8.	<b>H8 Maintenance</b>	
"↓"	S1 Dis- / Re-connect loop / zone line input S2 Acknowledge SERVICE signal S3 Clear weekly average S4 Test of alarm devices S5 Safe shut down of control unit S6 Activate address in alarm mode S7 Synchronize the control units S8 Activate / Reset outputs	
Scroll to menu S4.	<b>S4 Test of alarm devices</b>	
"↓"	Test of alarm devices control unit: 00 All Press ↓ to start test.	Write control unit number or press "▶" for "All". Press "↓" to start the test.
"↓"	Test of alarm devices, control unit 00 in progress. Press ↓ to end test	The test will continue for one hour if not stopped via this menu (S4) or if a fire alarm is activated in the system. Press "↓" to terminate the test.
"↓"	Test of alarm devices ended. Press ↓ to return to menu	
"↓"	<b>S4 Test alarm devices</b>	Scroll to another menu or press "ESC".

The OWS can be tested by testing the alarm output that triggers the OWS.

<sup>41</sup> For the alarm devices 3379, 4461, 4482 and 4487, the tone with the highest priority level (and type "alarm device") will be automatically selected.

## 29.5 Safe Shut Down of Control Unit (H8/S5)

**It's not recommended** to power down a Control Unit (i.e. no 230 V<sub>AC</sub> and no battery) without first performing a safe shut down of the Control Unit. Safe shut down will save the SSW in a Flash memory and put the CPUs at rest.

If no safe shutdown is performed, it may also generate a fault when you power up the control unit again:

**FAULT:** Read/write site data (SSW), control unit xx"

**It's highly recommended** to perform a safe shut down after commissioning the installation and calibrating the supervised outputs, changing passwords etc. in order to save the new valid values and codes.

Safe shut down can be performed from any Control Unit and any Control Unit can be selected. A Control Unit without a front has to be shut down from another Control Unit.

**Note:** By restart and power down, the Fault TX output(s) will be "activated".

Action	Text in display	Comments
"Menu" Log on to FT1020G3		According to Section 6.2, page 42.
Scroll to menu H8.	<b>H8 Maintenance</b>	
"↓"	<b>S1 Dis- / Re-connect loop / zone line input</b> S2 Acknowledge SERVICE signal S3 Clear weekly average S4 Test of alarm devices S5 Safe shut down of control unit S6 Activate address in alarm mode S7 Synchronize the control units S8 Activate / Reset outputs	
Scroll to menu S5.	<b>S5 Safe shut down of control unit</b>	
"↓"	Shut down control unit 00? <b>No</b> Yes	Write control unit number and press "▼" to select "Yes".
"▼" "↓"	Ready for shut-down, break the power. Automatic restart within xxx seconds!  <i>xxx will start at 300 seconds and countdown to 000 before the control unit will restart automatically. During the countdown the buzzer will start sounding since the communication between the Main and MMI boards has stopped. (Can be silenced via push button "Silence buzzer".)</i>	The SSW is now saved and the Main board and MMI board CPUs are at rest. <u>You can now power down the control unit.</u> If not, the control unit will restart automatically after 300 seconds (5 minutes).

<p>Power off / Power on <u>or</u> after 5 min.</p>	<p>FAULT: Restart control unit 00, code 53, address 0 dd-mm-yyyy hh:mm /Serviced</p> <p>FAULT: Restart control unit 00, code 03, address 0 dd-mm-yyyy hh:mm /Serviced</p> <p>Fault 1/2 is selected</p> <p>Previous page      Next page</p>	<p>After a restart (see page 108) two restart faults will be always exist. The code will be 00 / 50 after Power off / Power on restart and 03 / 53 after a countdown restart, address 0. This fault has to be acknowledged, see chapter "Fault Acknowledge", page 87.</p>
--	--	---

Code 50 and 53 respectively will only appear if the control unit has an MMI board.

**Note:** Prior the very first *safe shut down*, the Flash Memory is empty. Then every time *safe shut down* is performed the valid data will be saved in the Flash memory, i.e. some of the old data will be overwritten. When the FDCIE is powered up, the data stored in the Flash memory will be used.

**WARNING:** If *safe shut down* is **not** performed just before the FDCIE power down, then when powered on, the Flash memory may be empty i.e. default setting will be used or the stored data may be old / not valid.



**Note:** In all other Control Units in the system, the alarm will be presented as a Test mode alarm.

**Note:** If a real fire alarm occurs, the "Test mode alarm" will be automatically reset. A detector programmed for "Quiet alarm" will activate a Quiet alarm instead of a fire alarm

## 29.7 Synchronise the Control Units (H8/S7)

After any Control Unit restart in a network system, synchronisation will start automatically. Synchronisation can also be started via EBLWin and this menu (H8/S7).

The Control Units must be synchronised when the following fault message is shown:

**FAULT: Control unit xx has wrong information**

During the synchronisation, the following information will be displayed in all Control Units in the system:

⤵ (rotating clockwise) = Synchronisation in progress for the Control Unit (CU).

√ = Synchronisation completed successfully for the Control Unit (CU).

<Blank> = Synchronisation failed for the Control Unit (CU).

Action	Text in display	Comments																														
"Menu" Log on to FT1020G3		According to Section 6.2, page 42.																														
Scroll to menu H8.	<b>H8 Maintenance</b>																															
"↓"	<b>S1 Dis- / Re-connect loop / zone line input</b> S2 Acknowledge SERVICE signal S3 Clear weekly average S4 Test of alarm devices S5 Safe shut down of control unit S6 Activate address in alarm mode S7 Synchronize the control units S8 Activate / Reset outputs																															
Scroll to menu S7.	<b>S7 Synchronize the control units</b>																															
"↓"	Start synchronization? <b>No</b> Yes	Press "▼", to select "Yes". Press "↓" to start the synchronisation.																														
"▼" "↓"	Synchronisation in progress...  <table style="width: 100%; border-collapse: collapse;"> <tr> <td>CU00 ⤵</td> <td>CU10 ⤵</td> <td>CU20 ⤵</td> </tr> <tr> <td>CU01 ⤵</td> <td>CU11 ⤵</td> <td>CU21 ⤵</td> </tr> <tr> <td>CU02 ⤵</td> <td>CU12 ⤵</td> <td>CU22 ⤵</td> </tr> <tr> <td>CU03 ⤵</td> <td>CU13 ⤵</td> <td>CU23 ⤵</td> </tr> <tr> <td>CU04 ⤵</td> <td>CU14 ⤵</td> <td>CU24 ⤵</td> </tr> <tr> <td>CU05 ⤵</td> <td></td> <td>CU25 ⤵</td> </tr> <tr> <td>CU06 ⤵</td> <td></td> <td>CU26 ⤵</td> </tr> <tr> <td>CU07 ⤵</td> <td>CU17 ⤵</td> <td>CU27 ⤵</td> </tr> <tr> <td>CU08 ⤵</td> <td>CU18 ⤵</td> <td>CU28 ⤵</td> </tr> <tr> <td>CU09 ⤵</td> <td>CU19 ⤵</td> <td>CU29 ⤵</td> </tr> </table>	CU00 ⤵	CU10 ⤵	CU20 ⤵	CU01 ⤵	CU11 ⤵	CU21 ⤵	CU02 ⤵	CU12 ⤵	CU22 ⤵	CU03 ⤵	CU13 ⤵	CU23 ⤵	CU04 ⤵	CU14 ⤵	CU24 ⤵	CU05 ⤵		CU25 ⤵	CU06 ⤵		CU26 ⤵	CU07 ⤵	CU17 ⤵	CU27 ⤵	CU08 ⤵	CU18 ⤵	CU28 ⤵	CU09 ⤵	CU19 ⤵	CU29 ⤵	During the synchronisation, the progress symbol for each control unit is shown.  In the example shown, CU15 & CU16 are not programmed.
CU00 ⤵	CU10 ⤵	CU20 ⤵																														
CU01 ⤵	CU11 ⤵	CU21 ⤵																														
CU02 ⤵	CU12 ⤵	CU22 ⤵																														
CU03 ⤵	CU13 ⤵	CU23 ⤵																														
CU04 ⤵	CU14 ⤵	CU24 ⤵																														
CU05 ⤵		CU25 ⤵																														
CU06 ⤵		CU26 ⤵																														
CU07 ⤵	CU17 ⤵	CU27 ⤵																														
CU08 ⤵	CU18 ⤵	CU28 ⤵																														
CU09 ⤵	CU19 ⤵	CU29 ⤵																														
After a while.	Synchronisation completed dd-mm-yyyy hh:mm																															

	CU00 ✓ CU01 ✓ CU02 ✓ CU03 ✓ CU04 ✓ CU05 ✓ CU06 ✓ CU07 ✓ CU08 ✓ CU09 ✓	CU10 ✓ CU11 ✓ CU12 ✓ CU13 ✓ CU14 ✓  CU17 ✓ CU18 ✓ CU19 ✓	CU20 ✓ CU21 ✓ CU22 ✓ CU23 ✓ CU24 ✓ CU25 ✓ CU26 ✓ CU27 ✓ CU28 ✓ CU29 ✓	<p>Date and time for the latest completed synchronisation.</p> <p>The symbol "✓" means that the synchronisation process has been completed successfully.</p> <p>If the symbol "✓" is missing, the synchronisation is failed.</p>
"ESC"	Start synchronization? <b>No</b> Yes			
"ESC"	<b>S7 Synchronize the control units</b>			Scroll to another menu or press "ESC".

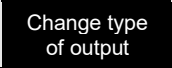

<p>"→ "</p>	<p>-- Activate -----          Loop unit ____ output _          Reset list (1) _____          Loop unit 000001 output 0</p> <p style="text-align: center;">  </p>	<p>Select in the Reset list with "▼" (in this example there is only one output) and press "↓".</p> <p>The reset output will disappear from the list, indicated with a beep.</p>
<p>"↓"</p>	<p>Activate _____          Loop unit 000000 output 0</p> <p style="text-align: center;">  </p>	<p>Continue as above or press "ESC".</p>
<p>"ESC"</p>	<p>S8 Activate / Reset output</p>	<p>Scroll to another menu or press "ESC".</p>

## 30 Interlocking Outputs and Inputs (H9)

### 30.1 Activated Interlocking Outputs / Inputs (H9/C1)

Action	Text in display	Comments
"Menu" Log on to FT1020G3		According to Section 6.2, page 42.
Scroll to menu H9.	<b>H9 Interlocking outputs and inputs</b>	
"↓"	<b>C1 Activated interlocking outputs / inputs</b> C2 Activate / deactivate interlocking output C3 Disable / re-enable interlocking output	
"↓"	<b>C1 Activated interlocking outputs / inputs</b>	Activated interlocking outputs and inputs can be listed in menu C1.
"↓" Depending on activated outputs, and/or inputs, the following will be shown:	<p>Interlocking area AAA point PP output active User definable text message (if programmed) dd-mm-yyyy hh:mm</p> <hr/> <p>Interlocking area AAA point PP input/output active User definable text message (if programmed) dd-mm-yyyy hh:mm</p> <hr/> <p>Interlocking area AAA point PP input active User definable text message (if programmed) dd-mm-yyyy hh:mm</p> <p style="text-align: center;">3 of 5</p>	It is a dynamic list in which you can scroll with "▼" or "▲".
"ESC"	<b>C1 Activated interlocking outputs / inputs</b>	Scroll to another menu or press "ESC".

## 30.2 Activate / Deactivate Interlocking Output (H9/C2)

The output in each interlocking combination (area / point) can be manually activated via this menu. The corresponding interlocking input will be "monitored" in the same way as if the output was activated by its control expression.

The output in each interlocking combination (area / point) can be manually deactivated via this menu.

**Note:** The output will be deactivated if its control expression still true and can't be activated again until the control expression has been false. Also, a latched output will be deactivated.

If an interlocking output is activated via its control expression and with latching output selected (in EBLWin), the output must be deactivated via this menu.

Action	Text in display	Comments
"Menu" Log on to FT1020G3		According to Section 6.2, page 42.
Scroll to menu H9.	<b>H9 Interlocking outputs and inputs</b>	
"↓"	<b>C1 Activated interlocking outputs / inputs</b> C2 Activate / deactivate interlocking output C3 Disable / re-enable interlocking output	
Scroll to menu C2.	<b>C2 Activate / deactivate interlocking output</b>	
"↓"	Activate _____ Interlocking output area: 000 point: 00	Write area number and address and press "↓" to activate, which will be indicated with "√" and a beep. The output will directly be shown in the Deactivate list.
Write the area number and point (e.g. 001 and 01). "↓"	Activate _____ Interlocking output area: 001 point: 01      √ -- Deactivate list (1) ----- Interlocking output area: 001 point: 01	If the specified output doesn't exist, it will be indicated with "X" instead of "√" and a beep. Use the soft key "→ " to toggle between <b>Activate</b> and <b>Deactivate list</b> .
"→ "	-- Activate ----- Interlocking output area: ___ point: ___ <b>Deactivate list (1)</b> Interlocking output area: 001 point: 01	Select in the Deactivate list with "▼" (in this example there is only one output) and press "↓". The deactivated output will disappear from the list, indicated with a beep.



"↓"	Activate [redacted] Interlocking output area: 000 point: 00	Continue as above or press "ESC".
"ESC"	<b>C2 Activate / deactivate interlocking output</b>	Scroll to another menu or press "ESC".

### 30.3 Disable / re-enable interlocking output (H9/C3)

Interlocking outputs (Type = Interlocking) can be individually disabled via this menu (and collectively via menu H2/B3). The "Interlocking Combination" (Area / Point) is to be entered to disable the output. Up to 100 interlocking outputs can be disabled in the whole system.



Disabled interlocking outputs are listed in menu H4/U1.

The LED Fault / Disablesments "General disablesments" (L10) is also indicating one or more disabled interlocking outputs.

Action	Text in display	Comments
"Menu" Log on to FT1020G3		According to Section 6.2, page 42.
Scroll to menu H9.	<b>H9 Interlocking outputs and inputs</b>	
"↓"	<b>C1 Activated interlocking outputs / inputs</b> C2 Activate / deactivate interlocking output C3 Disable / re-enable interlocking output	
Scroll to menu C3	<b>C3 Disable / re-enable interlocking output</b>	Interlocking outputs can be disabled / re-enabled via menu C3.
"↓"	Disable Interlocking output area: 000 point: 00	Write area number and address and press "↓" to disable, which will be indicated with "√" and a beep. The output will be automatically shown in the Re-enable list.
Write the area number and point (e.g. 001 and 01). "↓"	Disable Interlocking output area: 001 point: 01 √ -- Re-enable list (1) ----- Interlocking output area: 001 point: 01 	If the specified output doesn't exist, it will be indicated with "X" instead of "√" and a beep. Use the soft key "→ " to toggle between <b>Disable</b> and <b>Re-enable list</b> .
"→ "	-- Disable ----- Interlocking output area: ___ point: __ <b>Re-enable list (1)</b> <b>Interlocking output area: 001 point: 01</b> 	Select in the Re-enable list with "▼" (in this example there is only one output) and press "↓". The re-enabled output will disappear from the list, indicated with a beep.
"↓"	Disable Interlocking output area: 000 point: 00	Continue as above or press "ESC".
"ESC"	<b>C3 Disable / re-enable interlocking output</b>	Scroll to another menu or press "ESC".

## 31 Change Password (H10)

A password changed via menu H10 (followed by safe shutdown of control unit via H8/S5) will be valid until it is changed via menu H10 again or it is erased via EBLWin (menu Tools / Reset user passwords). When a password is required to be changed via EBLWin, a new SSD download must be downloaded.

Action	Text in display	Comments
"Menu" Log on to FT1020G3		According to Section 6.2, page 42.
Scroll to menu H10.	<b>H10 Change password</b>	
"↓"		
"↓"	Log in name Password: █ New password:                      Verify:	
Enter the old password, the new password and again the new password.	Log in name Password: ***** New password: *****                      Verify: *****	The six digits are replaced by ***** in the display.
	Incorrect password, NO change or Password changed 	
"ESC"	 menu H1 Perform monthly test H2 Disable or re-enable H3 Set calendar and clock H4 Present system status H5 Service H6 FAULT Acknowledge H7 Perform ZONE TEST H8 Maintenance H9 Interlocking outputs and inputs <b>H10 Change password</b>  <b>Escape menu</b>	The password is now changed to the new one. Scroll to another menu or press "ESC" or "Escape menu".

**Note:** After change of password, it is recommended to do a "Safe shutdown of the Control Unit" (see menu H8/S5). This will save the SSW data.

## 32 FDCIE Maintenance

The FDCIE shall be maintained and tested in accordance with the Australian standard AS1851.

To avoid the Fault TX output(s) to be activated, they can be disabled via menu H2/B5 (or via an open door, see chapter "Open door" page 56. However, in Australia the routing equipment **must** be isolated via the ASE.

Regarding the fault condition, see chapter "Fault", page 70 and "Fault messages", page 71

**Note:** Most of the faults have approximately 60 seconds delay.

Each control unit should be tested as follows:

- Perform monthly / quarterly / yearly test (menu H1).
- Remove one battery fuse (e.g. F2 on the Main board 5012). The following fault message will be shown within one minute:

FAULT: Battery not connected CU xx  
 NOTE! xx is depending on control unit (xx=00-29).

- Re-place the fuse and acknowledge the fault (menu H6).
- Check the manual call points on the panel door. Take required measures. Use the manual call point test key to activate fire alarm.
- Check some control outputs. Are they activated according to programmed control expressions?

### 32.1 Replacing a TLON Connection Board and/or the Main Board

In a TLON network programming, some unique data is stored in a memory on the 5090 TLON connection board and some stored in a memory on the main board.

**Note:** The main board 5012 is not compatible with the old TLON connection board 1590.

#### Replacing only a TLON connection board 5090

After replacing the board:

- In TLON Manager version 1.2 do "Replace", "Update" and "Save".
- In TLON Manager version  $\geq$  V2.0 do "Replace" and "Update" ("Save" is automatically done).

#### Replacing both a TLON connection board 5090 and also the Main Board

After replacing the boards:

- In TLON Manager version 1.2 do "Replace", "Update" and "Save".
- In TLON Manager version  $\geq$  V2.0 do "Replace" and "Update" ("Save" is automatically done).

#### Replacing the Main board

After replacing the main board, mount the TLON connection board(s) in the same position as on the replaced main board:

- In TLON Manager version 1.2 do "Update" and "Save".
- In TLON Manager version  $\geq$  V2.0 do "Update" ("Save" is automatically done).

If main board 5012 is installed, as a replacement to main board 5010, there might be a high resistance fault in the system. If there is a high resistance fault in the system after the replacement, it is recommended to switch the loop resistance monitoring off via a checkbox, when level 1 is activated.

To disable the function 'Monitor loop resistance'.

- a) Go to EBLWin menu Tools/ Advanced functions/ Level 1.
- b) Activate Level 1. The checkbox 'Monitor loop resistance' will appear in the properties for COM loops.

Checkbox is not marked = This function is disabled, which means the loop resistance will not be monitored.

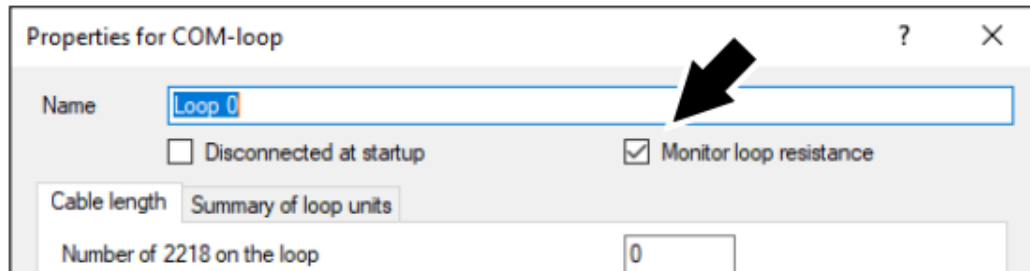

**Note:** It is not recommended to disable "Monitor loop resistance" function. High resistance loop fault requires to be troubleshooted. Refer to EBL512 G3 V3.6.x Planning Instructions section 23.1 'Calculation of Cable Length in EBLWin' to get approximate calculation of loop parameters.

## 32.2 Battery Maintenance

The batteries 2 x 12 V (battery size is dependent on the backup requirement), are placed inside the Control Unit. Larger batteries ( $\leq 65$  AH) can be placed in a separate battery box attached to the FT1020G3 cabinet.

The Control Unit charges the batteries and continuously monitor its condition, a fault will be generated when the batteries are disconnected or outside the specified limits.

The batteries are rechargeable Sealed Lead-Acid batteries, it must be approved batteries by CSIRO. The batteries are normally maintenance-free but the manufacturer's instructions should always be followed.

The ambient temperature affects the battery's capacity, self-discharge and life span. The temperature should preferably not be higher than normal room temperature (approx. 20-22°C). For highest safety, the batteries used in a fire alarm installation should be changed after two year or load tested annually.

**CAUTION:** Risk of explosion may occur if batteries are replaced by incorrect type. Dispose used batteries according to the producer's instructions and national regulations.

## 33 How to Avoid Nuisance Fire Alarms

We all realise when life, buildings, production facilities, etc. should be protected, it is of utmost importance that an initial fire is detected as soon as possible. That's why more reliable automatic fire alarm systems are installed.

In an automatic fire alarm installation, especially if smoke detectors (sensors) are used, everybody in the building needs to be informed how to avoid nuisance fire alarms.

To avoid troubles and unnecessary expenses there are a couple of things to bear in mind. Here are some advices and tips.

### **Tobacco smoke**

The detectors (sensors) cannot differentiate between different types of smoke. They cannot separate tobacco smoke from smouldering smoke. Intensive tobacco smoking in conjunction with poor ventilation can cause a fire alarm.

Welding, grinding, cutting, sawing & drilling, these types of activities may generate smoke.

### **Carpet welding**

Welding of plastic carpets causes a smoke that can be almost invisible, but it still influences the smoke detectors (sensors).

### **Cooking fumes, toasting & candles**

It is not only "normal smoke" that influences smoke detectors (sensors). It is all kinds of "combustion products", caused by cooking (frying/grilling), toasting, etc.

**Warning:** Be careful when smoke detectors (sensors) are mounted near / close to such activities.

### **Special environments**

Certain premises and environments can influence smoke detectors (sensors) and cause alarms. It can be ions (from plastics), flour dust, oil haze, aerosols, strong perfumes, strong ventilation, insecticides, disinfecting sprays, etc. If many odd and unnecessary alarms occur, the environment must be examined and perhaps other detector types have to be chosen.

### **Steam / hot air**

Smoke and heat detectors are influenced by steam and hot air, e.g. from an oven, dry-blower, heater, etc.

### **Exhausts**

Exhausts from cars / trucks, lift trucks, lawn mowers, etc. influences smoke detectors (sensors). If windows and doors are open, exhausts can "slip in" that way.

### **Lack of maintenance**

Smoke detectors (sensors) are influenced by their environment and become "dirty". In an analogue system (like FT1020G3), a Service signal is given when it is time to clean or exchange the smoke detectors (sensors). The alternative is to exchange detectors at even intervals, to be on the safe side.

### **Change in activities or wrong choice of detector**

If the activities in the premises are altered, the detector choice might also need altering. Due to some of the special environments shown above, an in-appropriate detector type might have been chosen from the beginning and thus cause unnecessary alarms.

### **Actions via EBLWin**

Choosing another type of detector, e.g. a multi detector (with both heat and smoke detection), can solve certain problems. Note that the coverage area can be different for different types of detectors.

It is however not always the best action is to change detector type. Here is a list of other actions, programmed via EBLWin, which can be used:

- Another alarm algorithm can be used (e.g. during working hours).
- Alarm Delay Facility (ADF) for analogue smoke sensor / detector and sounder bases combination can be used.

- 
- Alarm verification Facility (AVF) can be used for convention zone inputs.
  - Two-zone or two-unit dependent (co-occurrence) fire alarm activation can be used.
  - In an installation with addressable detectors / sensors (e.g. FT1020G3), the affected detectors can be individually disabled (or whole zones) for temporary work in the premises. Bear in mind that the smoke spreads, and consideration must be taken to adjacent detectors / zones. Disablements can be done automatically via a time channel (built-in or external) or via menu (H2/). Automatic re-enabling can be used. Zone disable card (if fitted) can also be used to manually disable a zone of smoke detectors.
  - If there are some alarm investigation procedures for the personnel on site, the alert annunciation function can be used.
  - Pre-warning can be used as an initial warning before a fire alarm is activated.

---

## 34 Block Wiring Diagram

---

The general arrangement drawings and connection diagrams quoted in this manual are shown in Figure 22. Detailed drawings and connection diagrams are available in a separate document (M436), only 4 drawings are shown in this manual:

- M637-0 19" Rack 22U FT1020G3 General Arrangement with optional 6U battery box
- M637-1 19" Rack 13U FT1020G3 General Arrangement with optional 6U battery box
- F822 FT1020G3 Standard Block Wiring Diagram
- F823 FT1020G3 New 5012 PCB Layout

For a full set of other drawings, refer to FT1020G3 drawing manual M436

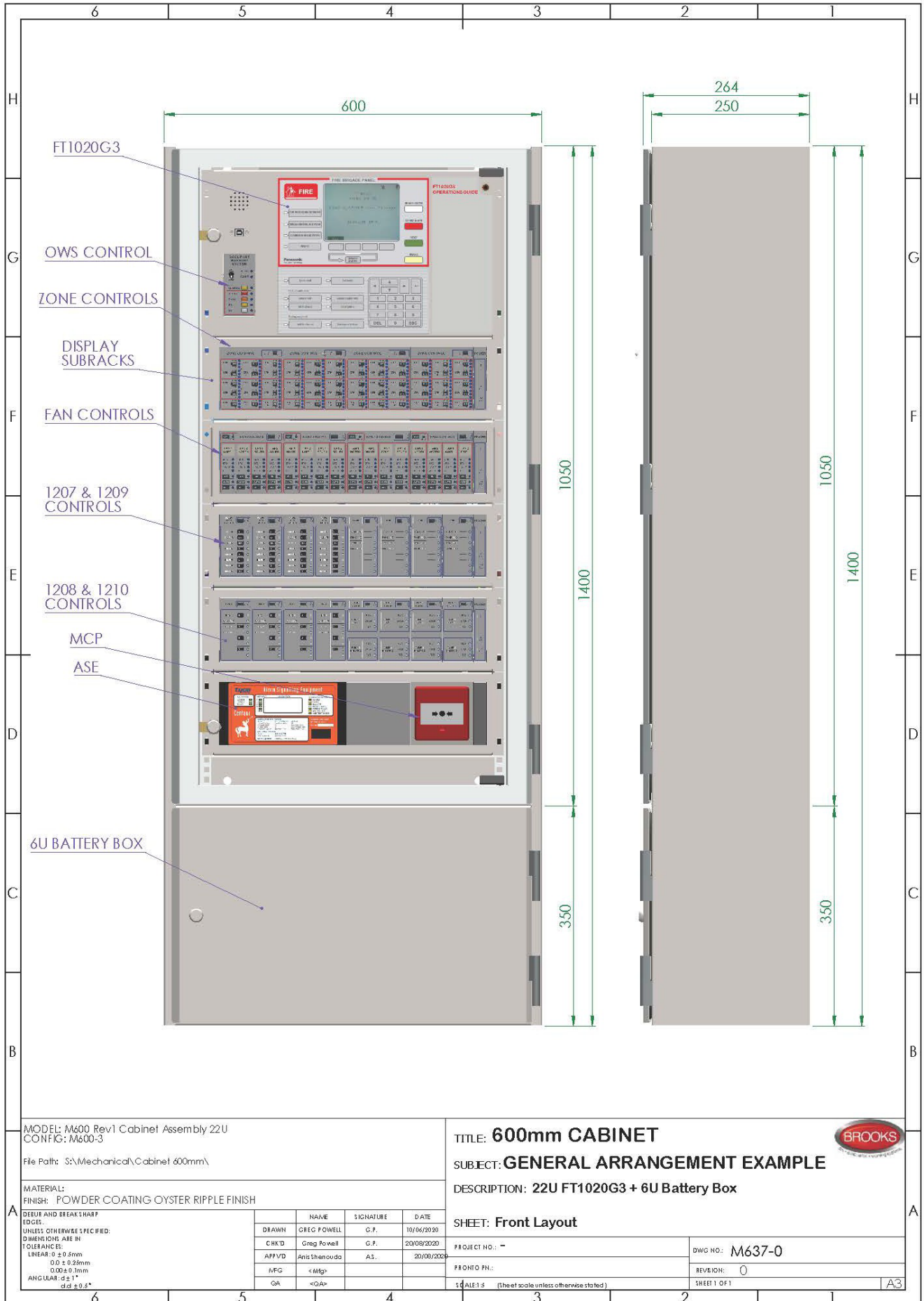
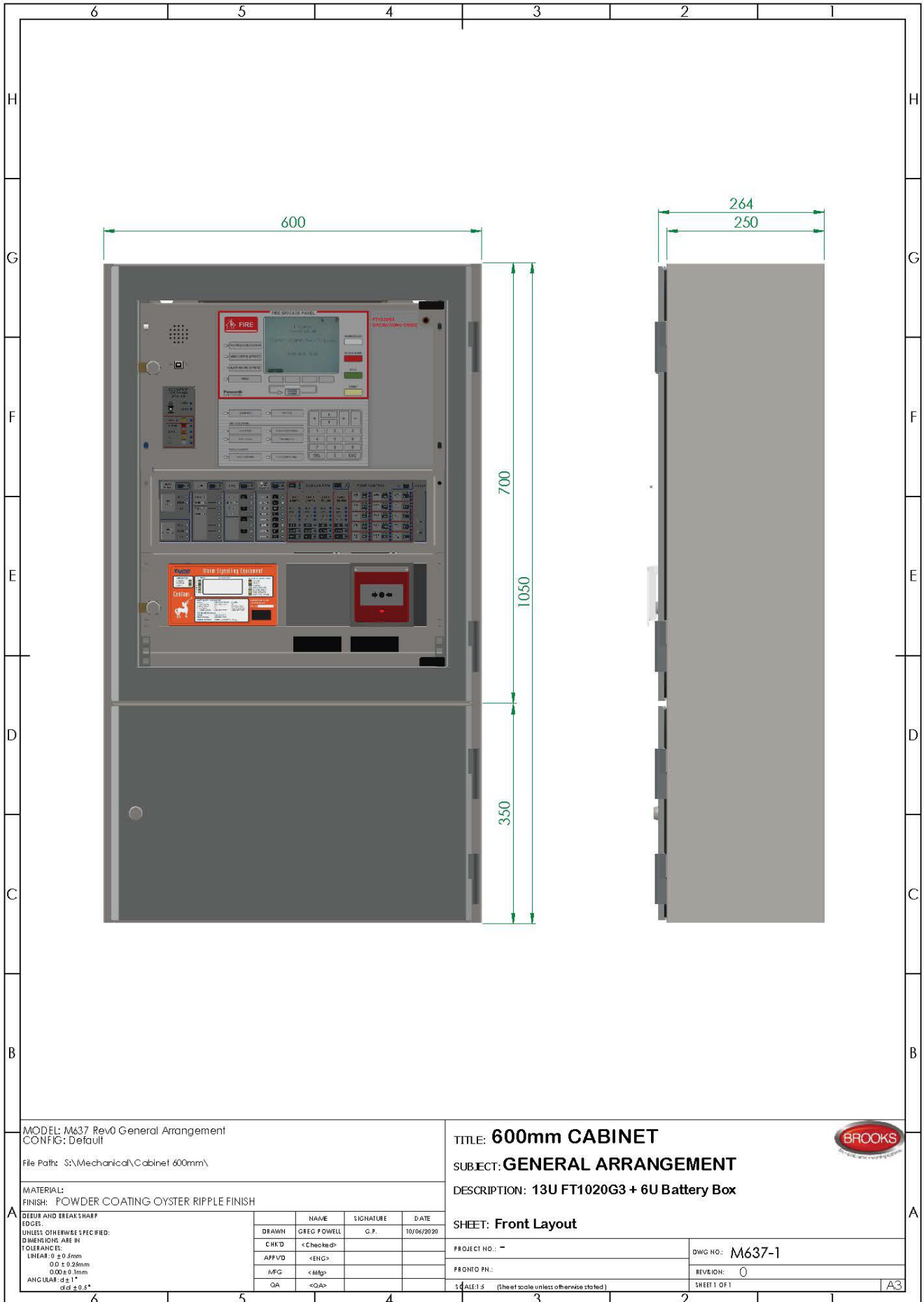

Figure 22 19" Rack 22U FT1020G3 General Arrangement with 6U battery box



MODEL: M637 Rev0 General Arrangement  
 CONFIG: Default  
 File Path: S:\Mechanical\Cabinet\600mm\  
 MATERIAL:  
 FINISH: POWDER COATING OYSTER RIPPLE FINISH

**TITLE: 600mm CABINET**  
**SUBJECT: GENERAL ARRANGEMENT**  
**DESCRIPTION: 13U FT1020G3 + 6U Battery Box**



DEBUR AND BREAK SHARP EDGES.  
 UNLESS OTHERWISE SPECIFIED: DIMENSIONS ARE IN  
 TOLERANCES:  
 LINEAR:  $\pm 0.5mm$   
 $0.0 \pm 0.25mm$   
 $0.00 \pm 0.1mm$   
 ANGULAR:  $\pm 1^\circ$   
 $\pm 0.5^\circ$

DRAWN	NAME	SIGNATURE	DATE
GREG POWELL	G.P.		10/06/2020
CHK'D	<Checked>		
APP'VD	<ENG>		
MFG	<Mfg>		
QA	<QA>		

**SHEET: Front Layout**  
 PROJECT NO.: -  
 DWG NO: M637-1  
 FRONT PN.:  
 REVISION: 0  
 SCALE: 1:1 (Sheet scale unless otherwise stated)  
 SHEET 1 OF 1

Figure 23 19" Rack 13U FT1020G3 General Arrangement with 6U battery box



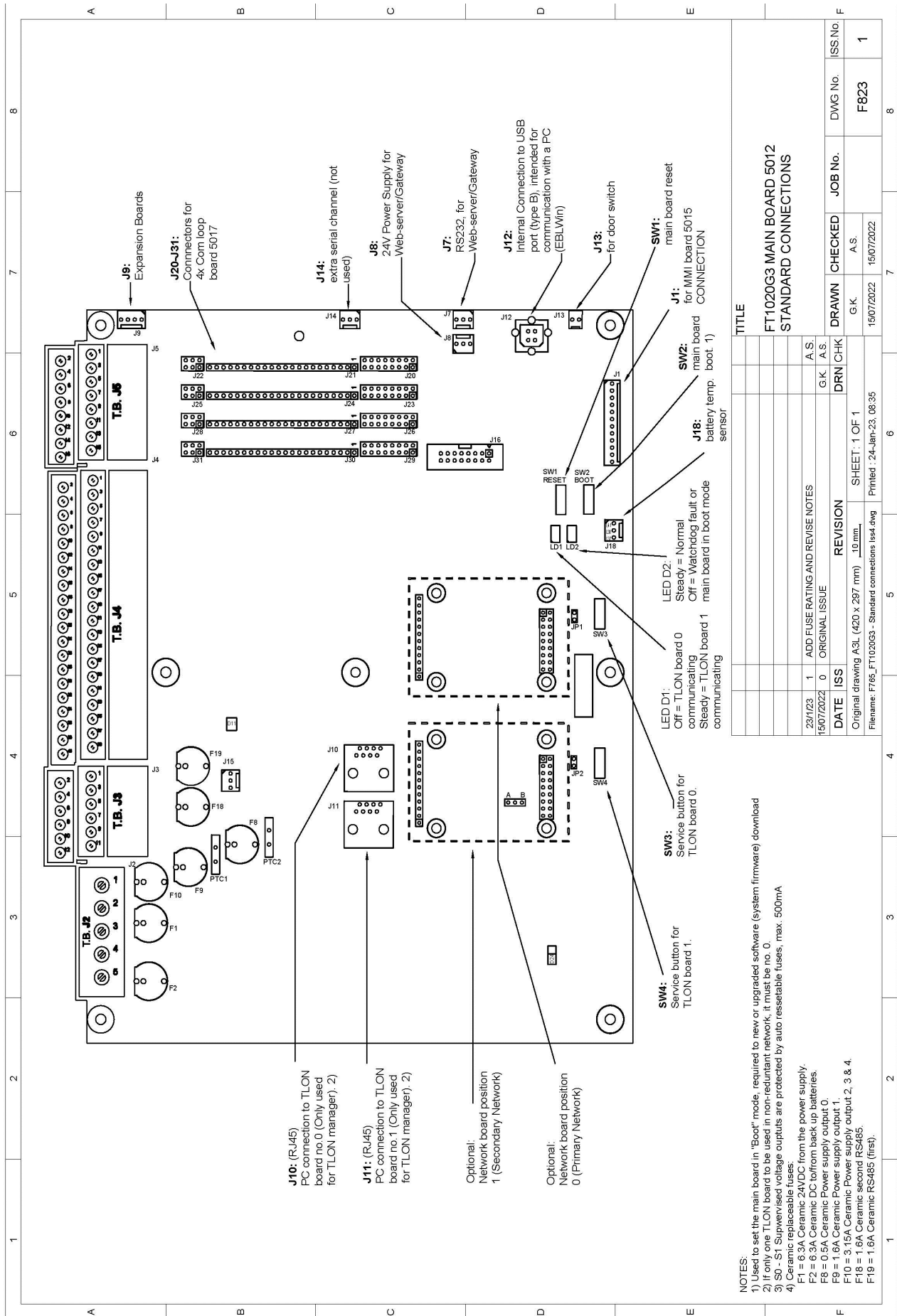

TITLE	
FT1020G3 MAIN BOARD 5012 STANDARD CONNECTIONS	
DRAWN	G.K.
CHECKED	A.S.
ISS No.	1507/2022
DWG No.	F-823
JOB No.	

DATE	ISS	REVISION	DRN	CHK	SHEET: 1 OF 1
23/1/23	1	ADD FUSE RATING AND REVISE NOTES	A.S.	A.S.	
15/07/2022	0	ORIGINAL ISSUE	G.K.	A.S.	

Filename: F765\_FT1020G3 - Standard connections Iss4.dwg  
Printed: 24-Jan-23, 08:35

**NOTES:**

- Used to set the main board in "Boot" mode, required to new or upgraded software (system firmware) download
- If only one TLON board to be used in non-redundant network, it must be no. 0.
- SO - S1 Supervised voltage outputs are protected by auto resettable fuses, max. 500mA
- Ceramic replaceable fuses:
  - F1 = 6.3A Ceramic 24VDC from the power supply.
  - F2 = 6.3A Ceramic DC to/from back up batteries.
  - F8 = 0.5A Ceramic Power supply output 0.
  - F9 = 1.6A Ceramic Power supply output 1.
  - F10 = 3.15A Ceramic Power supply output 2, 3 & 4.
  - F18 = 1.6A Ceramic second RS485.
  - F19 = 1.6A Ceramic RS485 (first).

Figure 25 FT1020G3 New 5012 PCB Layout

---

## 35 Guarantee

---

If the product has any defect due to faulty workmanship or material it is to be returned to BROOKS freight paid. BROOKS will, at its sole discretion, repair or replace the item free of charge.

On returning a component or complete product, proof of purchase will be required. If returning the complete product all accessories and documentation **MUST** be returned.

This guarantee does not cover damage caused to the product or its components as a result of incorrect installation, accident, negligence, misuse, unauthorised dismantling or contamination howsoever caused, careless handling or where repairs have been made or attempted by others. Onsite warranty repairs will be carried out at the discretion of the manufacturer.

No other guarantees written or verbal are authorised to be made on behalf of BROOKS. All other conditions and warranties whether expressed or implied are, to the extent permitted by law, hereby excluded.

As BROOKS has no control over the system's design, installation to the relevant Australian Standard or maintenance, the Company and its agents take no responsibility for any damage, consequential loss or injury caused to any equipment, property or persons resulting from the use of FT1020G3.

Brooks guarantees FT1020G3 for a period of 15 months from the date of purchase the equipment or 12 months from the date of operation.

## 36 Revision history

### 36.1 Operation Manual Revisions Table

Issue	Date	Description	Written By	Checked By
Rev 0	11/06/10	Original Panasonic manual	J.P.	
Rev 1	4/01/12	Update the original MEW01351 Rev 1 document to suit AU & NZ market	A.S.	ET / AS
Rev 1.1	20/04/12	Update drawing F765 to Issue 4	E.T.	A.S.
Rev 2.0	22/02/13	Update for S/W V2.0.0	A.S.	C. O.
Rev 2.1	30/05/14	Update for software V2.1	A.S.	
Rev 2.1.1	20/11/14	Minor update to include S/W V2.1.1	A.S.	
Rev 2.2	12/08/15	Minor update to include S/W V2.2.x & added Local Alarm Acknowledgement (LAA). Update Section 35 Block Wiring Diagram and drawings.	ET / AS	A.S.
Rev 2.4	20/04/18	Update for S/W V2.4.x, add new 19" rack cabinet, new Brooks 19"rack display and field modules.	ET / AS	A.S.
Rev 2.8	26/08/20	Update software to V2.8.x	A.S.	
Rev 2.10	12/05/21	Update software to V2.10 & correct some features	A.S.	H.N.
Rev 2.10.4	22/02/23	Revise manual to include new 5012 & 5015	A.S.	H.N.
Rev 3.6.0	10/11/23	Update software to V3.6.x	N.S	A.S

### 36.2 Software Revision V3.6.0 Enhancement Features

Refer to Technical bulletin TB214

**NSW - Head Office**

P.O. Box 7050 Silverwater NSW 1811  
4 Pike Street Rydalmere NSW 2116  
Ph: 02 9684 1466  
Website: [www.Brooks.com.au](http://www.Brooks.com.au)

**VIC**

9/71 Victoria Crescent, Abbotsford VIC 3067  
Ph: 03 9879 5294

**SA**

P.O. Box 101 Woodville SA 5011  
729A Port Road, Woodville, SA 5011  
Ph: 08 8347 0000

**QLD**

P.O. Box 511 Archerfield QLD 4108  
2/49 Boyland Ave Coopers Plains, QLD 4108  
Ph: 07 3373 8222

**WA**

P.O. Box 2114, Midland DC W.A. 6936  
Ph: 08 6262 8095

Or National Australian Sales Number: 1300 78 FIRE (3473)  
For the cost of local call.



**Panasonic** ideas for life

