



Operation / Installation Manual

Occupant **W**arning **S**ystem

Models OWS-60W & OWS-120W Kits



DOCUMENT HISTORY

Issue	Date	Description	Written By	Checked By	Approved By
1	24 Jun 2008	Original Document.	A.S. / C.A.	A.S.	C.O.

Table of Contents

1	INTRODUCTION	4
1.1	Overview.....	4
1.2	Features	4
1.3	Specifications.....	4
2	OPERATIONS	5
2.1	Display Layouts	5
2.2	Mode of Operation.....	5
2.2.1	Isolate mode	6
2.2.2	Automatic mode.....	6
2.2.3	Manual mode.....	6
2.3	Fault Indications.....	6
2.4	Auxiliary Audio Input.....	6
3	PLANNING.....	7
3.1	System Components.....	7
3.2	Monitored Inputs and Outputs	7
3.3	OWS Main Control Board.....	8
3.3.1	Board layout and connections.....	8
3.3.2	On-Board LED indications	9
3.4	4 Zone Expansion Board.....	10
3.5	Audio Amplifiers.....	11
3.6	Power Supply & Battery Requirements	13
3.7	Fuse.....	14
3.8	Configurations.....	14
3.8.1	DIP switch settings.....	14
3.8.2	RS232 and RS485 selection.....	14
3.8.3	Voice message programming.....	14
3.9	Sound Level Adjustment.....	15
3.9.1	Audio volume adjustments.....	15
3.9.2	Tone generator volume.....	15
3.9.3	Microphone volume	15
3.9.4	Background music volume.....	15
4	Assembly Instructions	17
4.1	Supplied Kit Materials	17
4.2	Cables requirements	19
4.3	Tools Requirement	20
4.4	Display Board Assembly.....	21
4.4.1	Mounting Display Board (SUB868) on Optional Brooks Face Plate CB485	21
4.4.2	Mounting Display Board (SUB868) Directly onto Existing Panel Fascia	22
4.5	Audio Transformer Assembly 60 Watt.....	23
4.5.1	Mounting 60 W Audio Transformer onto Optional Brooks Equipment Plate cb486 or existing Brooks system.....	23
4.5.2	Mounting 60W Audio Transformer onto Existing Panel	24
4.6	Audio Transformer Assembly 150 Watt.....	25
4.6.1	Mounting 150W Audio Transformer onto Optional Brooks Equipment Plate CB486	25
4.6.2	Mounting 150W Audio Transformer onto Existing Panel	26
4.7	OWS Main Control Module (SUB860) and Amplifier	27
4.7.1	Mounting Main Control Module and Amplifier onto Brooks Equipment Plate.....	27
4.7.2	Mounting Main Control Module and Amplifier onto Existing Panel.....	29
4.8	Final procedures.....	29
5	Wiring of brooks ows	30

Figures List

Figure 1 Main display Layouts of the Brooks OWS Kits.....	5
Figure 2 Optional PA Zone Selection display Layouts.....	5
Figure 3 OWS Main Control Board Layout.....	8
Figure 4 Four Zone Expansion Board Layouts.....	10
Figure 5 Class-D 60W and 120W Audio Amplifier Board Layouts.....	12
Figure 6 Class-D 250W Audio Amplifier Board Layouts.....	12
Figure 7 Hardware required for system assembly.....	18
Figure 8 Assembly on Brooks Face Plate.....	21
Figure 9 Cut-out details in the panel fascia.....	21
Figure 10 Fitting Face Plate into Panel Fascia.....	22
Figure 11 Drilling details required on panel fascia.....	22
Figure 12 Assembly on Existing Panel Fascia.....	23
Figure 13 60 Watt Audio Transformer Wiring.....	23
Figure 14 60W Transformer Fitted into Brooks Equipment Plate.....	24
Figure 15 Brooks equipment plate CB586.....	24
Figure 16 Audio transformer fitted in existing panel.....	24
Figure 17 150W/100V Audio transformer wiring.....	25
Figure 18 Step 1 fixing mounting bracket onto Brooks equipment plate.....	25
Figure 19 Step 2 mounting transformer onto Brooks angle bracket.....	26
Figure 20 Step1 fixing mounting bracket onto existing panel.....	26
Figure 21 Step 2 mounting 150W transformer onto bracket.....	26
Figure 22 Fixing Spacers Required to Mount the Amplifier on Main Module.....	27
Figure 22 Mounting Main Control Module onto Brooks Equipment Plate.....	27
Figure 23 Mounting amplifier module on top of main module.....	27
Figure 24 Complete Assembly of Brooks OWS Plate.....	28
Figure 28 Main Control and Amplifier Modules (Picture).....	28
Figure 27 Fixing Brooks Equipment Plate into a panel.....	29
Figure 29 Wiring Diagram for Stand Alone 60W OWS.....	31
Figure 30 Wiring Diagram for Standalone 120W OWS.....	32
Figure 31 Wiring Diagram for Optional Stand Alone 250W OWS.....	33
Figure 32 Wiring Diagram for 4 Zone Split Module & PA Selection.....	34

Tables List

Table 1 General Specifications.....	4
Table 2 Monitored Inputs and Outputs.....	7
Table 3 Connections of the OWS Main Control Board.....	8
Table 4 LED indicators on the OWS Main Board.....	9
Table 5 Connections of the PA Zone Expansion Board.....	10
Table 6 Connections of the Audio Amplifier 60W, 120W and 250W.....	13
Table 7 Current consumption of OWS components.....	13
Table 8 Fuse Specifications.....	14
Table 9 DIP Switch Settings.....	14
Table 10 Sound Volume Adjustment.....	16
Table 11 Common Components.....	17
Table 12 Additional Components for 60W.....	17
Table 13 Additional Components for 120W.....	18
Table 14 Optional Fitting Kit Material.....	18
Table 15 Recommended cables.....	19

1 INTRODUCTION

1.1 Overview

The Brooks Occupant Warning System (OWS) is capable of providing reliable audio and visual warnings to building occupants via speakers and strobes. The system is designed to both alert occupants to an emergency situation and provide for evacuation should it be required. The standard system kits are available in 2 amplifier sizes, 60W amplifier “OWS60WKIT” or 120W amplifier “OWS120WKIT”.

This document provides the technical information required to configure, install, maintain and operate a Brooks OWS and its related components. This document should be read prior installation. Should you have any queries, please contact Brooks for technical support.

1.2 Features

A Brooks OWS kit comprises a main control board, a main display board, audio amplifier, optional PA speaker 4 zone expansion board, optional PA 8 zone display board and optional remote paging disk microphones.

The Brooks series of OWS kit systems have the following features.

1. Automatically switch from alert to evacuation tone in a configurable time period in emergency conditions. It can also be configured for one tone only (T3)
2. Configurable audio warnings with pre-recorded digital voice messages.
 - For Australian applications, it complies with the ISO7731 and the ISO8201 standards.
 - For New Zealand applications, it complies with the NZS4512 and the AS2220.1 standards.
 - For non regulatory applications, the tones and voice message can be customized.
3. Support both local and remote public address with optional remote microphone and PA zone controls (check space availability).
 - Local PA facility via a built-in electrets microphone.
 - Speaker output can be split into a max of 16 individual speaker circuits. Each circuit is individually supervised for short and open-circuit faults.
 - Optional remote desk microphone with an auxiliary input for background music and PA zone selection (if zone split module is fitted).
4. Intuitive indications and controls via the well-grouped LED indicators and momentary switches.
5. A range of Brooks class-D 100V audio amplifiers.
 - High power efficient with standby input to maximize its power conservation.
 - The available standard amplifiers are 60W and 120W. 20W or 250W amplifiers are available on customer’s request.
6. Sufficient inputs and outputs connect to the fire panels and the warning devices.
 - One supervised trigger input (clean N/O contact) to activate the audible and visual warnings from the fire panel or from any mechanical trigger (MCP).
 - One OWS fault clean contact relay output to signal fault condition.
 - One supervised 24V bi-polarity strobe output to provide alert and evacuation visual warnings.

1.3 Specifications

Table 1 General Specifications

Feature	Specification
Operating Temperature	0°C to +50°C.
Operating Humidity	5-95%, non-condensing.
Compliance	ISO 7731, ISO 8201 and Clause 3.22 of AS 1670.1

2 OPERATIONS

2.1 Display Layouts

The OWS display layout is shown as follows.

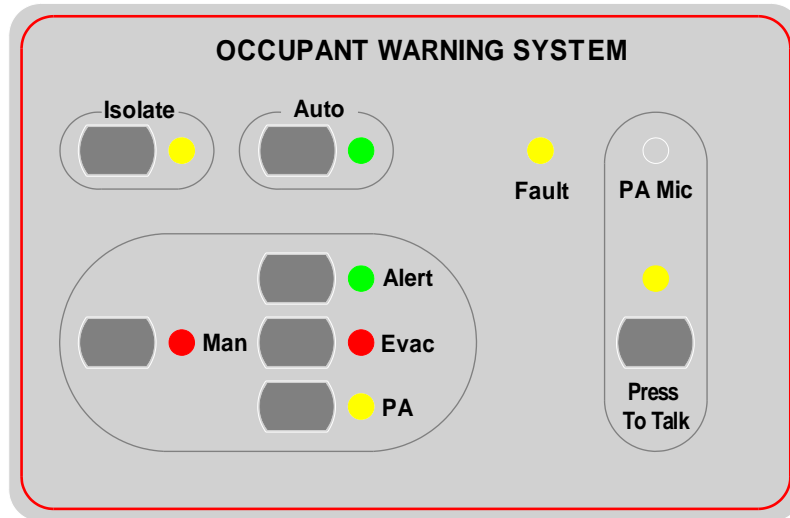

Figure 1 Main display Layouts of the Brooks OWS Kits

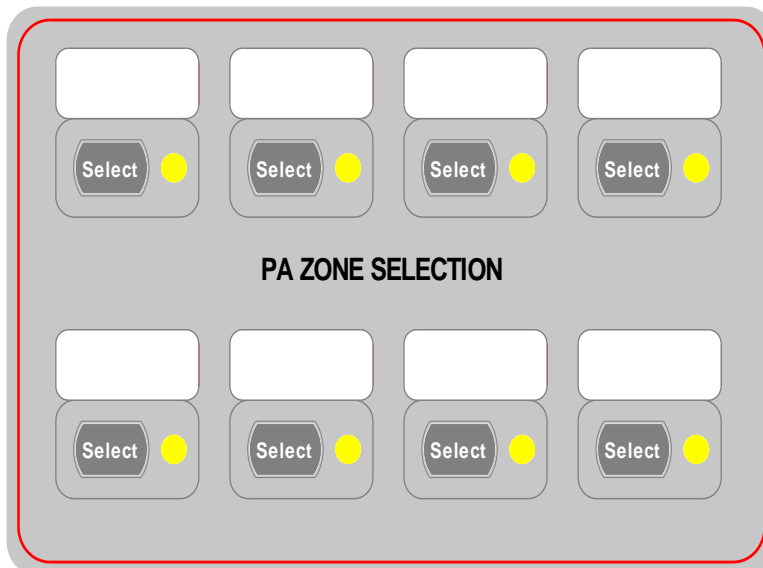

Figure 2 Optional PA Zone Selection display Layouts

2.2 Mode of Operation

Three operation modes are available: isolate, automatic or manual. Only one of these modes can be activated at any one time. A mode is selected by pressing the mode selection button on the display and is indicated as active by a LED next to the button. Pressing the mode selection button again will de-select the mode and return to the default automatic mode.

2.2.1 Isolate mode

The OWS operates in the isolate mode as follow:

- All the outputs are deactivated.
- All the alert, evacuation, PA and background music functions are disabled.
- When the trigger input is active, either the Alert or Evac LED will flash based on the settings.
- When a wiring fault is detected, the Fault LED illuminates, the fault relay remains in its active (normal) state
- In software version V1.5 and higher, when the system is isolated, the OWS system will, after a predetermined time (5 minutes) be in fault condition until the system is de-isolated and returns back to auto mode. This feature has been added to avoid leaving the system in non-auto mode.

2.2.2 Automatic mode

In this mode, if the trigger input is activated, the audio warning signals (tone and voice) will be broadcasted to all the speakers automatically. The bi-polarity strobe output will also be activated. Either the Alert or the Evac LED will flash based on the settings. The buzzer of the OWS will sound.

There are two ways to shutdown the activated warning signal as follow:

1. Press the Isolate button to enter the isolate mode.
2. Press the Manual button and then press either the alert or the evacuation button which is in active conditions (LED opposite to the switch is ON). Either the alert or the evacuation LED will keep flashing until the trigger input becomes inactive.

Note: A fault signal will be generated, after a predetermined time (5 minutes) if the isolate or manual mode is selected (V1.5 and higher)

2.2.3 Manual mode

In this mode, alert, evacuation or PA modes can be activated or deactivated manually.

If one or more PA zone expansion boards (max 4) are installed, the PA speaker zones can be individually enabled or disabled by pressing the related PA zone selection button. The LED next to each button will turn ON when the PA zone is selected.

To access the PA feature, the controller must be in manual mode. The following operations will activate the public address.

- Press the “Manual” control, the manual LED illuminates and a fault is generated after a predetermined time (5 minutes) (V1.5 and higher).
- Press the “PA” control, the PA LED illuminates.
- Press “Press to talk” button and while pressed speak into the microphone.
- The LED above the Press to talk button will illuminate when the microphone input is broadcasted.

2.3 Fault Indications

When a fault in the OWS is detected, the fault LED on the front display illuminates and the Fault relay will de-energise.

2.4 Auxiliary Audio Input

The auxiliary audio input is available in both automatic and manual modes. The audio signal is fed into the “AUX” audio input terminals and may be enabled or disabled via the “AUX. EN.” switch input. It supports either a local background music input or a remote desktop microphone. Please refer to the Brooks remote paging desktop microphone technical datasheet TDS002 for further details.

The auxiliary audio input can be activated only in the non alarm condition, it will be automatically overridden by any alarm signal (activated via the trigger input) or when manually selected for public address.

3 PLANNING

3.1 System Components

The following subassemblies can be used in the Brooks OWS based on the application requirements.

- SUB860, OWS main control module (supplied),
- SUB868, OWS main display board (supplied),
- SUB862, OWS PA zone expansion termination board (optional),
- SUB863 , OWS PA zone expansion display board (optional),
- SUB865, Audio amplifier, class-D, 60 W RMS (OWS60WKIT only),
- SUB866 , Audio amplifier, class-D, 120 W RMS (OWS120WKIT only),
- SUB867, Audio amplifier, class-D, 250 W RMS (special option),
- PA-1 Brooks remote paging desktop microphone with BGM / PA enable / disable control (optional),
- PA-8 Brooks remote paging desktop microphone with 8 PA zone selections (optional),
- PA-16 Brooks remote paging desktop microphone with 16 PA zone selections (optional).

Please note that the sub assembly numbers of the audio amplifiers are not same as the SUB number printed on the PCBs. The PCBs may be revised in future.

Please note that the Brooks OWS and its associated components are not designed for use in any hazard or high vibration environment.

3.2 Monitored Inputs and Outputs

The Brooks OWS has the following inputs and outputs which are monitored individually for open-circuit or short-circuit faults. Each input or output requires an End Of Line (EOL) resistor, 47K, 1%, metal film, 1/2W.

Table 2 Monitored Inputs and Outputs

Board	Item	Terminal
SUB860 OWS main control board	Warning trigger input	TB1, 11 – 12
	Bi-polarity strobe output	TB2, 3 – 4
	Speaker line output	TB2 , 13 – 14
SUB862 OWS PA zone expansion board	PA zone 1 output	CON3, 3 – 4
	PA zone 2 output	CON3, 5 – 6
	PA zone 3 output	CON3, 7 – 8
	PA zone 4 output	CON3, 9 – 10

3.3 OWS Main Control Board

3.3.1 Board layout and connections

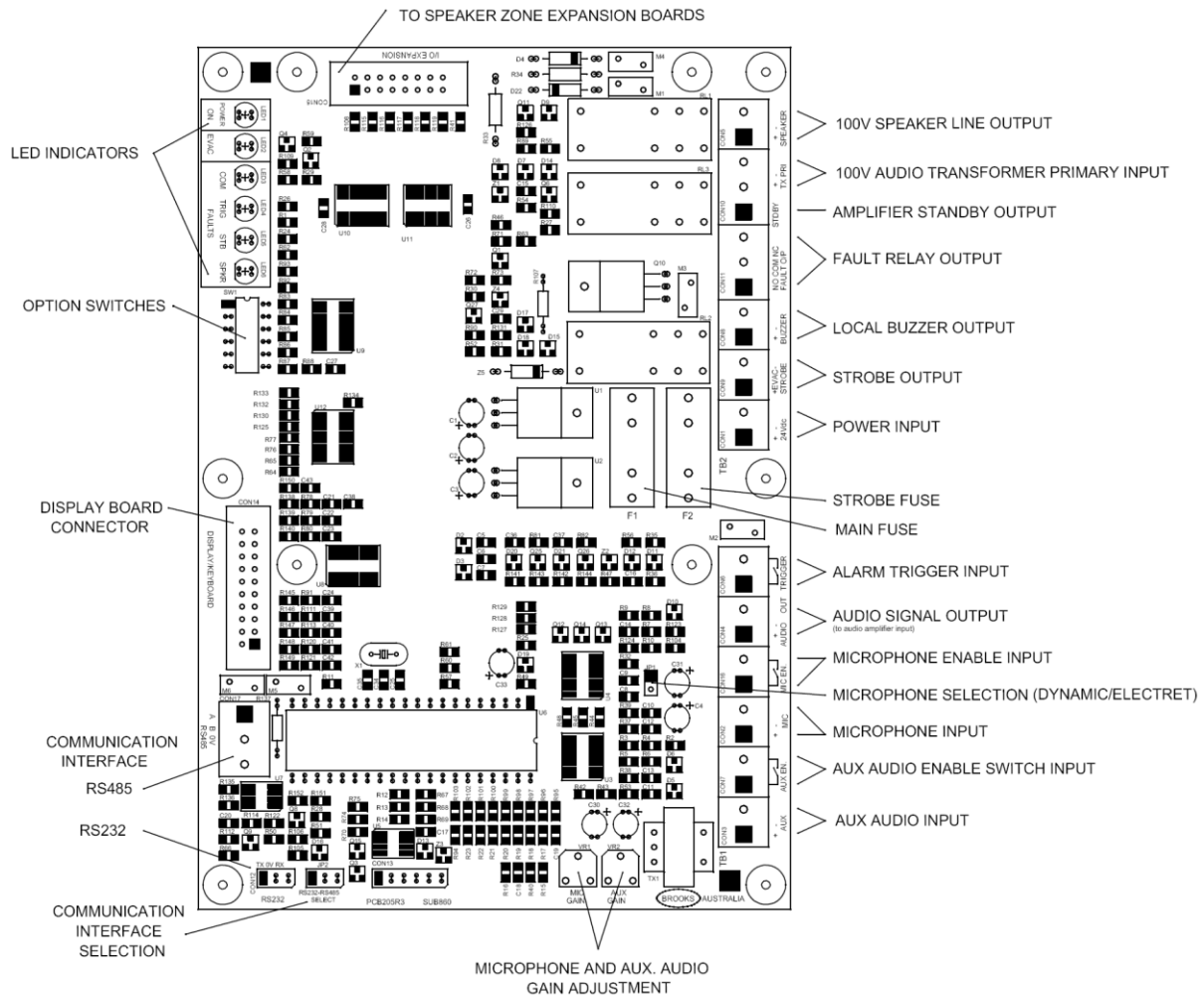

Figure 3 OWS Main Control Board Layout

All inputs, outputs and field wiring are terminated in the main control module as shown in above figure. The OWS main control provides trimpots for volume adjustments as shown in section 3.9 on page 15

Table 3 Connections of the OWS Main Control Board

Designator	Type	No.	Label	Pin	Description		
TB1	Screw terminal	1	AUX	+	Auxiliary audio input.		
		2		-	<= 1V RMS		
		3	AUX EN	+	Auxiliary audio enable input.		
		4		-	Short circuit is the active state.		
		5	MIC	+	Microphone input from the built-in electrets microphone.		
		6		-			
		7	MIC EN	+	Spare input. Not used. Leave it unconnected.		
		8		-			
		9	AUDIO OUT		Audio output to the amplifier. <= 1V RMS.		
		10					
				11	TRIGGER	+	Monitored trigger input. Connect to the N/O alarm contact in the fire panel or any N/O clean contact.
				12		-	EOL resistor: 47kΩ 0.5 Watt 1%.
TB2	Screw	1	24Vdc	+	24 Vdc supply from the CIE		

Designator	Type	No.	Label	Pin	Description
	terminal	2		-	
		3	EVAC STROBE	+/-	Monitored bi-polarity visual warning output. 20-30V, <=1A. The normal polarity is for alert and the reversed polarity is for evacuation. EOL resistor: 47kΩ 0.5 Watt 1%.
		4		-/+	
		5	BUZZER	+	Transistor open-collector output. 20-30V < 100mA. Drive the buzzer on the main display board
		6		-	
		7	FAULT O/C	NO	Wiring fault output. Dry-contact, <=30V, <= 5A Connects to the fire panel input. In normal conditions, the NC and COM is short-circuited. In wiring fault conditions, the NO and the COM is short-circuited.
		8		COM	
		9		NC	
		10	STDBY	+	Audio amplifier control output, logic 5V, <= 5mA. When it is high, the audio amplifier output will be disabled. For Brooks class-D amplifiers only.
		11	TX PRI	+	Transformer input. <100V RMS. Connect to the transformer primary coil output. The maximum current is based on the amplifier type.
		12		1	
		13	SPEAKER	+	Monitored speaker output. Connect to the speaker line or the optional PA zone expansion boards. EOL resistor: 47kΩ 0.5 Watt 1%.
		14		-	
CON7		Screw terminal	1	RS485	A
	2		B		
	3		0V		
CON12	Molex 3 Pin Header	1	RS232	TX	RS232 interface. TX – PC RX, RX – PC TX, 0V – PC GND. Used for digital voice message programming.
		2		0V	
		3		RX	
CON15	IDC header, 2X10	N/A	I/O EXPANSION	N/A	PA zone control board expansion interface. Connect to the first PA zone expansion board.
CON14	IDC header, 2X5	N/A	DISPLAY BOARD	+	IDC connector to the main keyboard.
CON13	IDC header, 2X10	N/A		N/A	Not used.

3.3.2 On-Board LED indications

Table 4 LED indicators on the OWS Main Board

Designator	Label	Color	Active conditions
LED1	POWER ON	Green	The OWS main board power input is ON.
LED 2	EVAC	Red	The warning trigger input is activated.
LED 3	FAULTS COM	Yellow	Common Fault, indicates speaker, strobe or trigger fault. If only COM Fault is ON, it may be a wiring fault in the 4 zone expansion card (SUB862).
LED 4	FAULTS TRIGGER	Yellow	The warning trigger input has a wiring fault. Flashing once per cycle indicates a short-circuit fault detected. Flashing twice indicates an open-circuit fault detected.
LED 5	FAULTS STB	Yellow	The strobe output has a wiring fault. Flashing once per cycle indicates a short-circuit fault detected. Flashing twice indicates an open-circuit fault detected.
LED 6	FAULTS SPEAKER	Yellow	The speaker output has a wiring fault. Flashing once per cycle indicates a short-circuit fault detected. Flashing twice indicates an open-circuit fault detected.

3.4 4 Zone Expansion Board

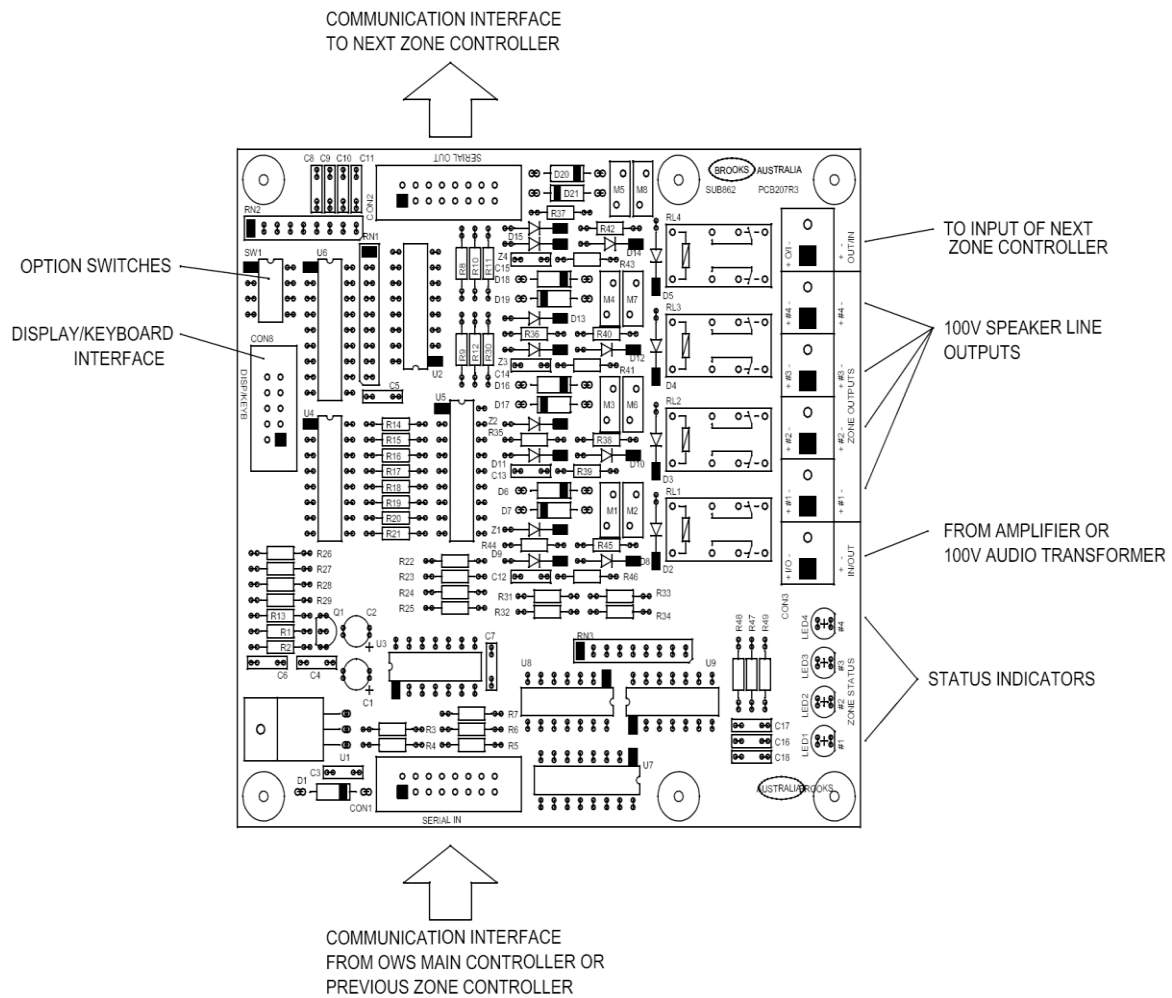

Figure 4 Four Zone Expansion Board Layouts

The OWS main control board has only a single zone speaker output. The optional SUB862, 4 zone expansion board, allows for the single zone speaker output of the main board to split into 4 individual speaker circuits. Each of the four speaker outputs is individually monitored for short and open circuit fault. The optional SUB863 allows the PA to be controlled over selected speaker zone only.

When an individual PA control is required, an eight PA zone selection module SUB863 can be used in conjunction with one or two zone expansion module (SUB862).

Up to four of the four zones expansion modules (SUB862) can be daisy-chained to provide a maximum of 16 speaker zones. Up to two of the eight PA selection modules (SUB863) can be used to control a maximum of 16 PA circuits (if SUB862 is used).

Four status LED indicators are provided to indicate the selected PA zone if the PA selections display board is used, it is a duplicate indication of the PA selection display board LEDs (if used).

Table 5 Connections of the PA Zone Expansion Board

Designator	Type	No.	Label	Pin	Description
CON1	IDC header, 2X8	N/A	SERIAL IN	N/A	PA expansion interface. Connect to the main control board or the previous PA zone expansion board.
CON2	IDC header, 2X8	N/A	SERIAL OUT	N/A	PA expansion interface. Connect to the next PA zone expansion board.
CON3	Screw terminal	1	IN/OUT	+	Audio source input from the main control board or the previous PA zone expansion board.
		2		-	

Designator	Type	No.	Label	Pin	Description		
		3	ZONE OUTPUT	+	PA zone 1output. Monitored. <= 100V RMS, <= 2A.		
		4		-			
		5		+	PA zone 2output. Monitored. <= 100V RMS, <= 2A.		
		6		-			
		7		+	PA zone 3output. Monitored. <= 100V RMS, <= 2A.		
		8		-			
		9		+	PA zone 4output. Monitored. <= 100V RMS, <= 2A.		
		10		-			
				11	OUT/IN	+	Audio source output to the next PA zone expansion board.
				12		-	
CON8	IDC header, 2X5	N/A	DISPLAY	N/A	PA zone expansion keyboard interface.		

3.5 Audio Amplifiers

Brooks OWS has a range of associated class-D audio amplifiers, which have the following features.

- High energy efficiency.
- Standby function to minimize the power consumption.
- Low Voltage protection.
- Over current protection for the 250W amplifier only.
- 60W and 120W amplifiers are mounted on the top of either the OWS main control board or the PA zone expansion to save space

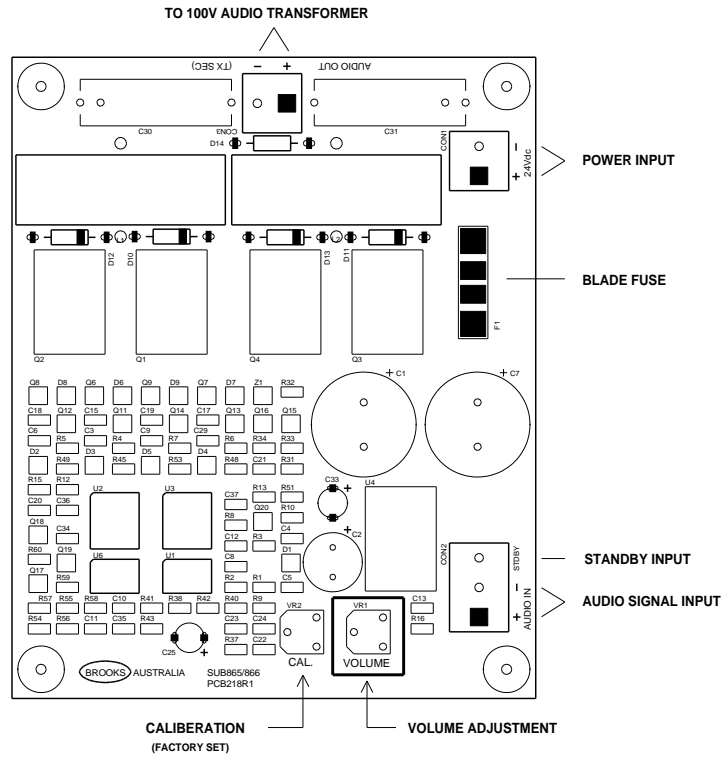

Figure 5 Class-D 60W and 120W Audio Amplifier Board Layouts

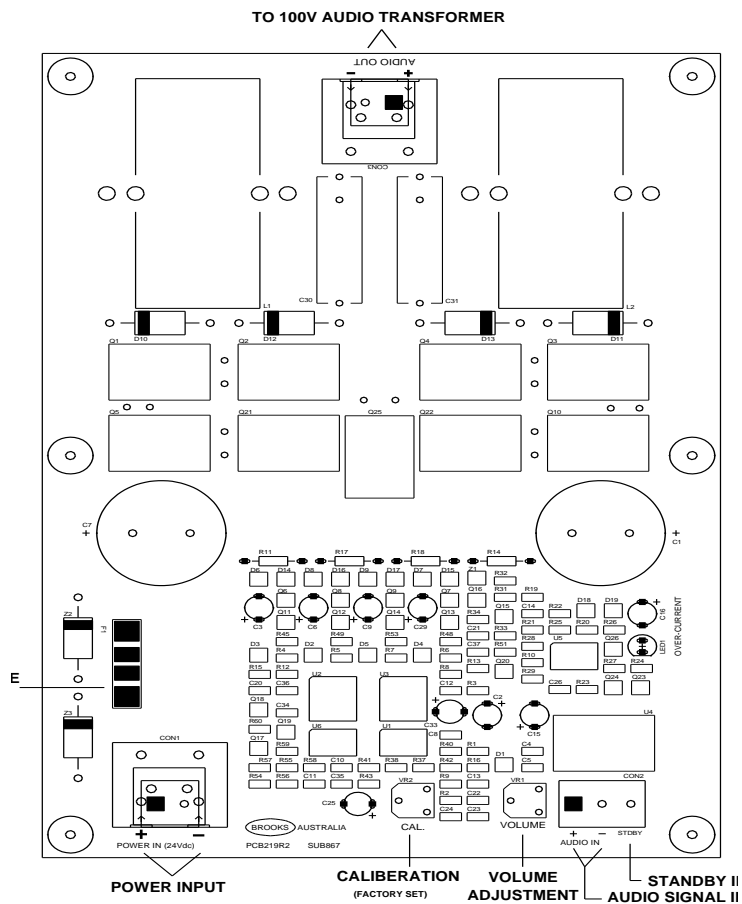

Figure 6 Class-D 250W Audio Amplifier Board Layouts

Table 6 Connections of the Audio Amplifier 60W, 120W and 250W

Designator	Type	No.	Label	Pin	Description
CON1	Screw terminal	1	24Vdc	+	Power input. 19V - 32V. < 3A (60W), 6A (120W), 11A (250W)
		2		-	
CON2	Screw terminal	1	AUDIO IN	+	Audio input from the main control board. <=1V RMS. Input impedance: 10K.
		2		-	
		3		STDBY	Audio amplifier enable/disable input, logic 5V, <= 5mA. It is to minimize the unit power consumption. The amplifier output will be disabled when the input is high.
CON3	Screw terminal	1	AUDIO OUTPUT	+	Audio output to the transformer primary side on the main control board. 16VRMS to the connected transformer.
		2		-	

3.6 Power Supply & Battery Requirements

The power supply of the CIE where the Brooks OWS kits are intended to be added must deliver sufficient current to operate the OWS in full load condition. Battery capacity shall be re-calculated to ensure supplying power for 24 hours in quiescent state and 30 minutes in alarm condition. The Brooks OWS kits require the battery capacity to be determined by the following:

- Standby time period when the system is in quiescent conditions and running on battery only.
- Maximum current time period when the system is in alarm conditions and running on battery only.
- System speaker load.
- Type of audio amplifier in system.
- The quiescent and alarm current consumptions of individual system components.

For a fully loaded 60W OWS, 7 AH batteries are sufficient based on 24 hours of quiescent current and 30 minutes of alarm current. 12 AH batteries can be used for a fully loaded 120 Watt OWS.

Table 7 Current consumption of OWS components

Module	Quiescent Current in mA		Full Load Current	Notes
	Standby	BGM Enabled		
OWS Main Control & Display	88	88		Max current depends on each amplifier
60 Watt Amplifier	40	95	3 A	
120 Watt Amplifier	40	140	5.5 A	
250 Watt Amplifier	40	140	11 A	
4 Zone Expansion Card	35 (all OFF)	150 (all ON)		
1 Zone Desktop Mic	9		40	
8 Zone Desktop Mic	20		100	All LEDs On

3.7 Fuse

The system fuses are listed as follows.

Table 8 Fuse Specifications

Board	Designator	Circuit Protected	Specification
Main Control Board	F1	Power Input	M205, glass sealed, fast blow 1A.
	F2	Strobe output	M205, glass sealed, fast blow 1A.
60W Audio Amplifier	F1	Power Input	ATO blade fuse 32VDC , 5A
120W Audio Amplifier	F1	Power Input	ATO blade fuse 32VDC , 7A
250W Audio Amplifier	F1	Power Input	ATO blade fuse 32VDC , 15A
Remote Desktop microphone	F1	Power input	M205, glass sealed, fast blow 1A in-line fuse inside the control panel.

3.8 Configurations

3.8.1 DIP switch settings

The DIP switch on the OWS main control board (SUB860) is used to configure the system for different applications. The default switch settings are all OFF. This DIP switch needs to be properly set to meet the application requirements.

Table 9 DIP Switch Settings

Function	Status		Descriptions
	S1	S2	
Time delay between Alert/Voice and Evac/Voice in auto mode	OFF	OFF	Evacuation tone / voice messages only (no delay).
	ON	OFF	One minute delay between alert tone/voice and Evac tone/voice message.
	OFF	ON	Three minutes delay between alert tone/voice and Evac tone/voice message.
	ON	ON	Five minutes delay between alert tone/voice and Evac tone/voice message.
Enable/disable voice with Alert	S3	ON	Voice message enabled with alert tone.
		OFF	Voice message disabled with alert tone.
Enable/disable voice with Evac	S4	ON	Voice message enabled with evacuation tone.
		OFF	Voice message disabled with evacuation tone.
Trigger input Latch/non-latch	S5	ON	Trigger input is latching. Must be disabled in manual mode
		OFF	Trigger input is non-latching, follows the trigger input in auto mode
AU / NZ Convention configuration	S6	ON	New Zealand convention, tones/messages comply with the AS2220.1 and the NZS4512 standards.
		OFF	Australian convention, tones(T3) / messages comply with the ISO7731 and ISO8201 standards.

3.8.2 RS232 and RS485 selection

The OWS main control board supports serial communication, the signal level can be configured to either RS232 or RS485 via jumper JP2 on the main control board. To download the audio sound file from a PC, the jumper needs to be set to the RS232. To support remote desktop microphones, the jumper needs to be set to the RS485 level.

- Jumper 1-2 installed for RS232 option,
- Jumper 2-3 installed for RS485 option.

3.8.3 Voice message programming

The alert and evacuation tones are software generated. The alert and evacuation voice messages are pre-recorded and stored in flash memory. The flash memory size is 524288 bytes which can provide

up to 30 seconds of voice message at sample rate 22.05 KHz The digital sound is in 8-bit resolution PCM format.

The digital sound files used in the OWS can be created using PC software such as the Sound Recorder provided by Microsoft Windows as an accessory software. The sound files then can be uploaded from a PC via RS232 connection to CON12 on the OWS main control board. If special tones or messages are required, please contact Brooks offices to organise the engineering department to upload the required files into the main OWS control board.

3.9 Sound Level Adjustment

The audio volume shall be adjusted to ensure that the required sound pressure level is met. The sound pressure level shall be measured by certificated and calibrated sounder meter which meets the requirements of the related standards, such as ISO7731.

The OWS uses a trimpot on the main control board and on the amplifiers as the sound level adjustment facilities. To adjust the sound level, tune the trimpots first and then measure the sound level according the related standards.

Please note that the warning sound level must be adjusted first.

3.9.1 Audio volume adjustments

Two trimpots VR1 and VR2 are provided on the main board to adjust the microphone and auxiliary gain input levels. Before adjusting the microphone and background music sound level, the volume for the tone/message generator must be adjusted first. The tone / message sound level is the reference volume to which all the other levels should be matched. The auxiliary gain adjustment should be adjusted in the centre position, probably there is no need to adjust the gain since the audio source itself can usually be adjusted.

3.9.2 Tone generator volume

The tone generator is utilised as the reference volume level to any other level and must be adjusted first (if required). In manual mode the alert / evacuation tones can be activated. While alert or evacuation tone is active, simply adjust the volume trimpot on the audio amplifier to the required level.

3.9.3 Microphone volume

Once the tone generator volume has been adjusted, on the front display, activate the PA function in the manual mode then press and hold the PTT button and speak into the microphone, adjust the microphone gain VR1 until the required volume level is reached.

3.9.4 Background music volume

The background music level can be adjusted in either manual or automatic modes as follow:

1. Adjust the aux gain control VR1 to the centre position.
2. Ensure that the PA or alert / evacuation tones have been turned off.
3. If Brooks remote desktop microphone is used, press the BGM enable button otherwise activate the auxiliary input on the main board (by shorting the aux. input terminal).
4. Set the volume level of the audio source (iPod, radio tuner, CD player,...).

If the required background music level cannot be reached, the auxiliary gain control VR2 should be adjusted. The gain control VR2 should not be adjusted to the maximum, since volume controls can be controlled by the audio player volume.

Table 10 summarises the volume and gain control in the OWS.

Table 10 Sound Volume Adjustment

Sound	Board	Trimpot	Sound Activation
Warning sound	Audio Amplifiers	VR1, Volume	<ul style="list-style-type: none"> • Enter the manual mode, • Press the evacuation key
Local microphone PA	Main control board	VR1, MIC GAIN	<ul style="list-style-type: none"> • Enter the manual mode, • Press the • PA key, Press and hold the PTT key. • Speak to the built-in microphone and the hand-held microphone if any.
Auxiliary audio	Main control board	VR2, AUX GAIN	<ul style="list-style-type: none"> • Enter Auto mode and confirm the system is in quiescent conditions. • Connect the sound source, such as an mp3 or CD player. • Keep the auxiliary enable input active.
Remote desktop microphone PA	Remote desktop microphone board	Please refer to the remote desktop microphone technical datasheet.	
Remote desktop microphone background music	Remote desktop microphone board	Please refer to the remote desktop microphone technical datasheet.	

4 ASSEMBLY INSTRUCTIONS

4.1 Supplied Kit Materials

The following table contains the common materials required to assemble either OWS60WKIT or OWS120WKIT

Table 11 Common Components

Component	Item Description	Quantity	Notes
CA117	20 Way Cable Assembly 1000	1	
LA???	Caution 100v Audio Line	3	
LA952	Decal Label Standard OWS	1	
MA385	Owners Instructions	1	
RS500	Resistor 0.25W MF 1% 47K	3	
SUB860	OWS Main Control Module	1	
SUB868	OWS Display Module (6 Stud)	1	
XC015	100mm General Purpose Cable Tie	5	
XC020	4 Way Cable Tie Base (19 x 19mm)	5	
XC025	Flat Ribbon Cable Clamp	5	
XF005	M3 Hex Nut	22	
XF010	M3 Internal Shake Proof Washer	26	
XF015	M3 Flat Washer	18	
XF023	M3 x 10mm Pan HD Philips + Washer	6	
XF024	M3 x 6mm Pan HD Philips + Washer	10	
XF027	M3 x 16mm Countersunk	6	
XF034	Hex Spacer M3 x 10mm	6	
XF040	Hex Spacer M3 x 25mm	4	
XF201	M4 Spring Washer	6	
XF207	M4 x 10mm Pan HD Philips	6	
XF211	M4 x 16mm Pan HD Philips	4	
XF320	M4 Hex Nut	6	
XF325	M4 Internal Shake Proof Washer	6	
XF330	M4 Flat Washer	10	
XF360	M4 x 5mm White Nylon Spacer	10	

The common components are used in both 60W and 120W kits in addition to one of the following tables for either one.

Table 12 Additional Components for 60W

Component	Item Description	Quantity	Notes
CC460	Cap E/Lytic 100uF/100v Axial	1	
SUB865	Class D Audio Amplifier 60W	1	
TX290	Audio Transformer 60W/100V	1	

Table 13 Additional Components for 120W

Component	Item Description	Quantity	Notes
CC465	Cap E/Lytic 220uF/100v Axial	1	
SUB866	Class D Audio Amplifier 120W	1	
TX300	Audio Transformer 150W/100V	1	

Table 14 Optional Fitting Kit Material

Component	Item Description	Quantity	Notes
CB485	OWS Display Mounting Plate	1	
CB486	OWS Equipment Mounting Plate	1	
CB487	Audio Transformer Mounting Bracket	1	

The previous list of materials requires some hardware components for mounting the subassemblies and available space on the equipment and face plates.

These items are shown in Figure

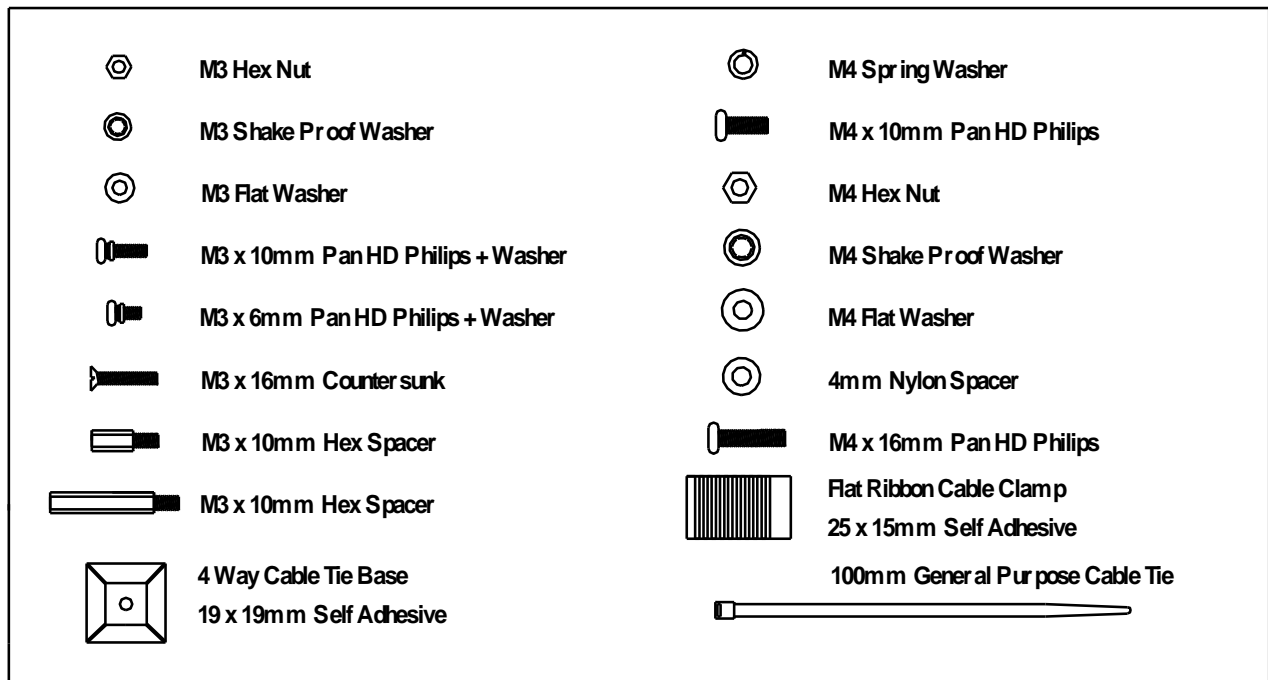

Figure 7 Hardware required for system assembly

4.2 Cables requirements

Brooks recommends using the cables specified in table 15 to wire the occupant warning system to the CIE and field wiring. All cables should be 250V insulated as a minimum requirement.

Please note, the cables are not part of the OWS kits.

Table 15 Recommended cables

Sequence	Item Description
A	Screened Audio Cable (microphone).
B	0.5mm ² Cable – Red (+24vdc) recommended.
C	0.5mm ² Cable – Black (0v) recommended.
D	1mm ² Cable – Brown (system audio) recommended.
E	1mm ² Cable – Blue (system audio) recommended.
F	Cabling for any “system fault” interconnection.
G	Cabling for external system “trigger”.

4.3 Tools Requirement

Depending on the method of installation, the following tools are required:

Method 1: Installed on the optional Brooks equipment plate CB486 and Brooks face plate CB485.

Sequence	Item Description
1a	4.5mm HSS Drill Bit or
1b	3.2mm HSS Drill Bit / 4mm Taper Tap.
2	Battery Drill.
3	Combination Pliers.
4	Jigsaw / Nibbler (control/display cutout)
5	M3 Hex Head Driver.
6	Philips Head Screwdriver.
7	Solder.
8	Soldering Iron.
9	Terminal Screwdriver.

Method 2: Drilled and tapped for fitting to other mounting surface.

Sequence	Item Description
1	Method 1 tool list.
2	12mm Countersinking Drill Bit.
3	2.5mm HSS Drill Bit.
4	3.2mm HSS Drill Bit.
5	3mm Taper Tap.
6	4mm HSS Drill Bit.
7	4mm Taper Tap.
8	8mm HSS Drill Bit.
9	Hand Tap Tool Holder (or other device to thread holes)

Method 3: Drilled for mounting with nuts and bolts on other mounting surface.

Sequence	Item Description
1	Method 1 tool list.
2	12mm Countersinking Drill Bit.
3	3.2mm HSS Drill Bit.
4	4mm HSS Drill Bit.
5	8mm HSS Drill Bit.

4.4 Display Board Assembly

4.4.1 Mounting Display Board (SUB868) on Optional Brooks Face Plate CB485

1. Assemble the display board SUB868 into Brooks face plate CB485 as shown in figure 8.
2. Affix the decal label on Brooks face plate, ensure LEDs and buttons are matching the holes and the buttons operate properly.
3. Using Figure 9 as a guide, cut a rectangular opening 134x79mm in the panel fascia.
4. Drill 4x4mm holes in the panel fascia as shown in figure 9.
5. Clean and remove all metal fillings from the panel.
6. Mount assembled Brooks face plate on the panel fascia using M4x10mm bolts, M4 nuts, washers, etc as shown in figure 10.

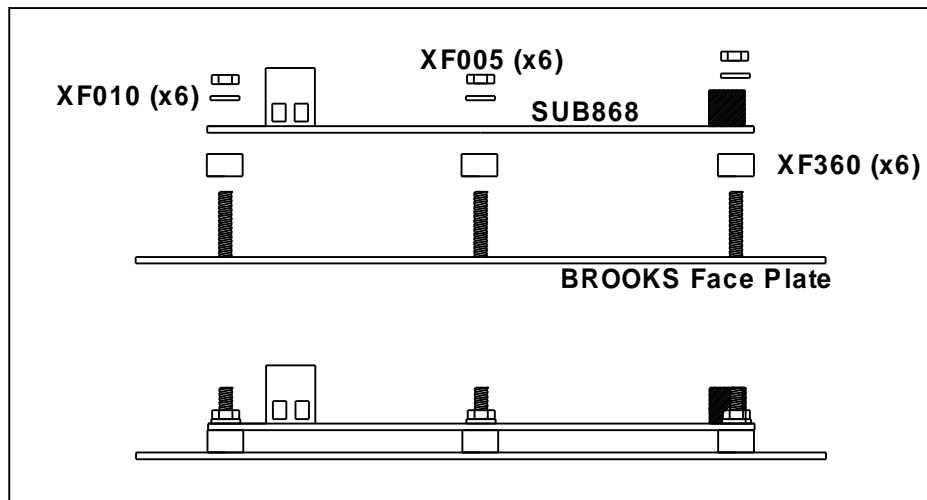

Figure 8 Assembly on Brooks Face Plate

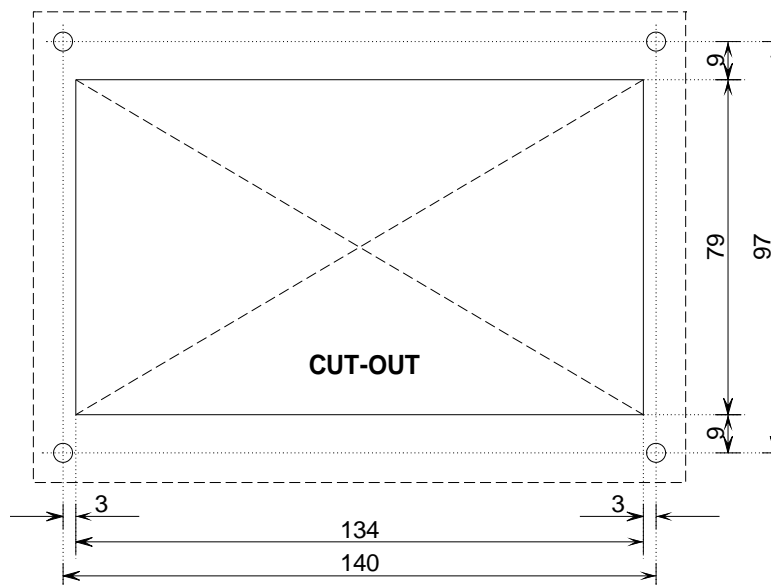

Figure 9 Cut-out details in the panel fascia

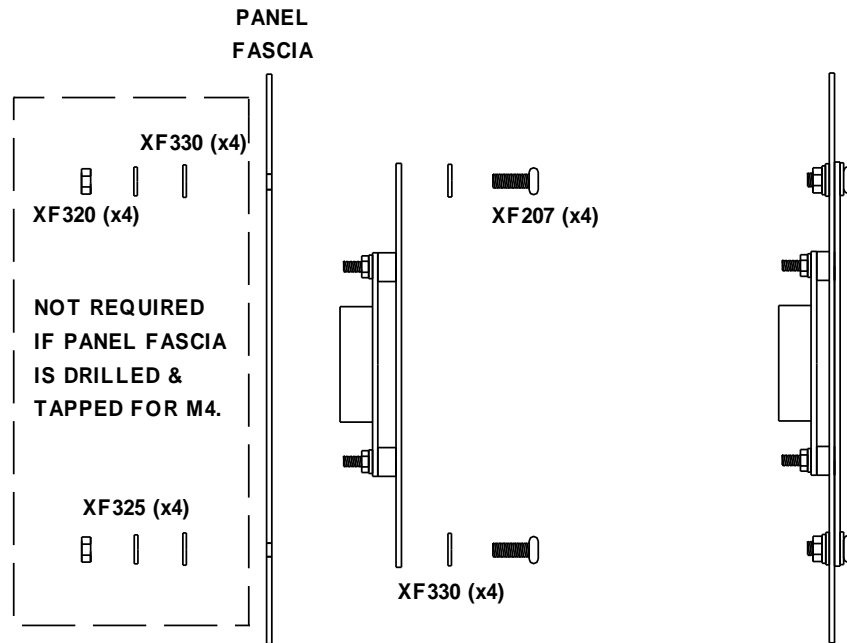

Figure 10 Fitting Face Plate into Panel Fascia

4.4.2 Mounting Display Board (SUB868) Directly onto Existing Panel Fascia

1. Cut out, locate and affix Face Plate template (template #1) to Panel Fascia.
2. Using template 1 as a guide, drill out HOLE B, using 3mm HSS drill bit.
3. Countersink the 3mm holes to accommodate the head of the M3 x 16mm fixings (XF027).
4. Using template 1 as a guide, drill out HOLE C, using 8mm HSS drill bit.
5. Using template 1 as a guide, drill out HOLE D, using 5mm HSS drill bit.
6. Clean and remove all metal filling etc from panel.
7. Fit SUB686 to panel fascia (see Figure 3).

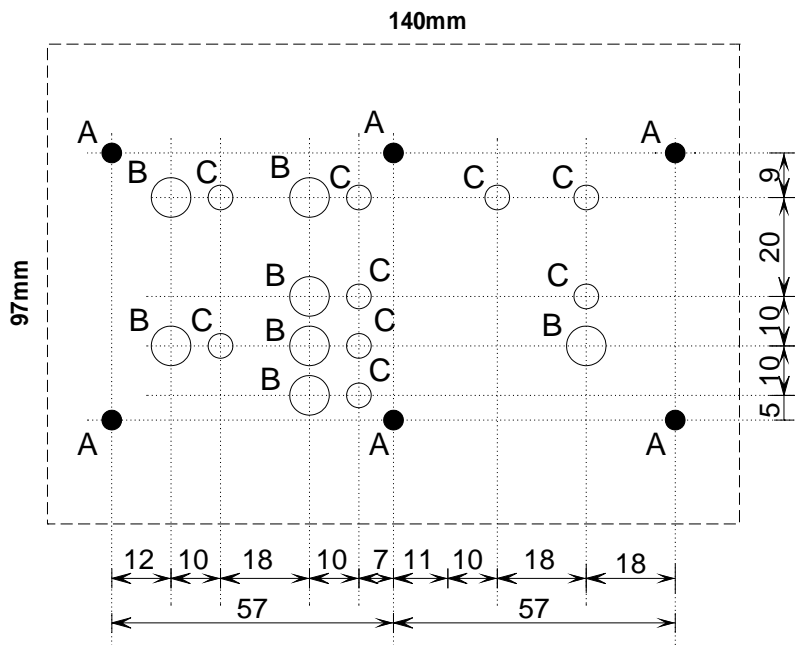

Figure 11 Drilling details required on panel fascia

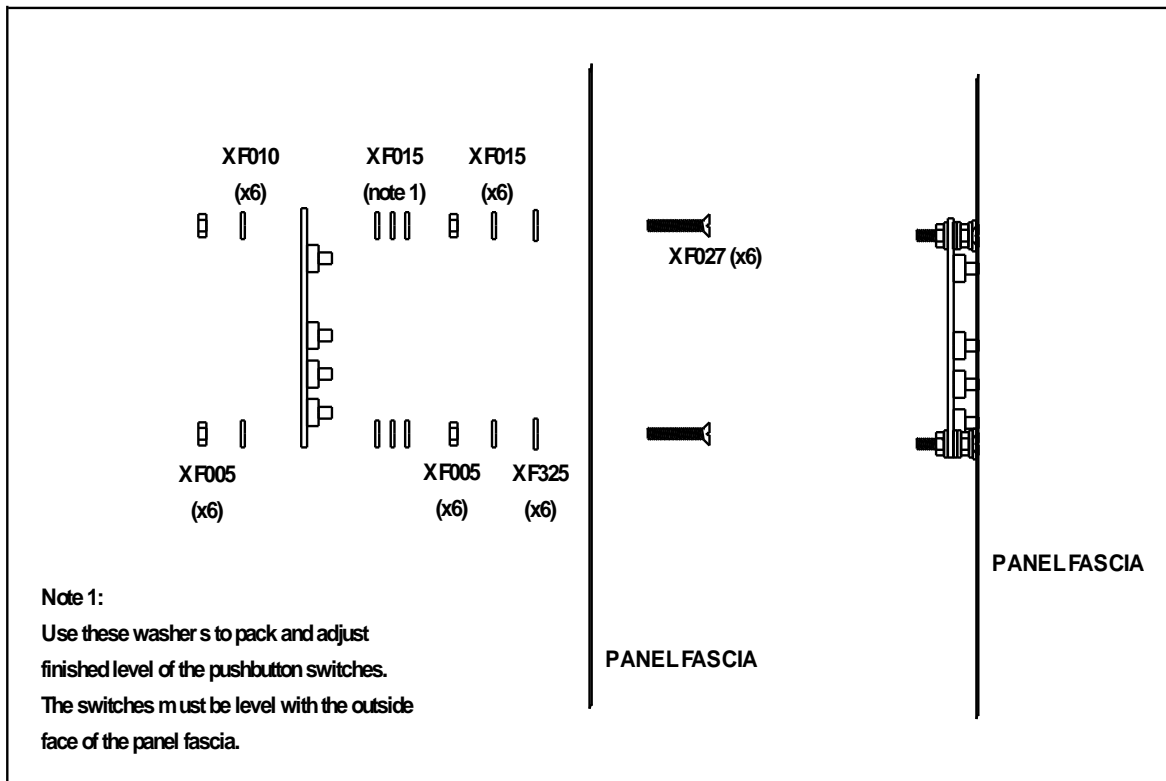

Figure 12 Assembly on Existing Panel Fascia

4.5 Audio Transformer Assembly 60 Watt

4.5.1 Mounting 60 W Audio Transformer onto Optional Brooks Equipment Plate cb486 or existing Brooks system

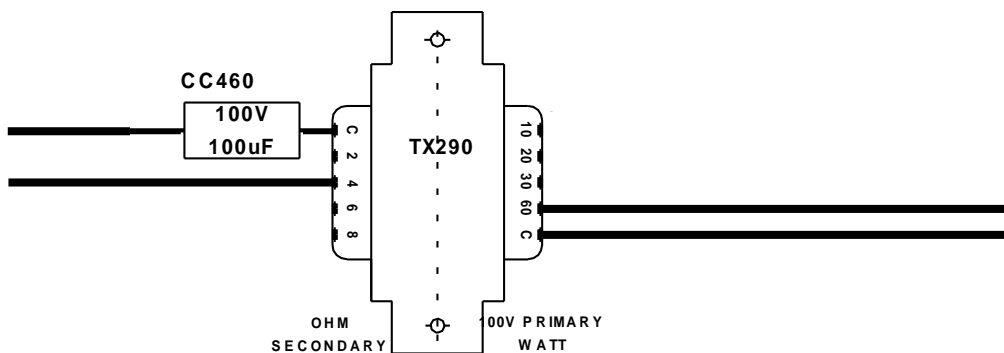

Figure 13 60 Watt Audio Transformer Wiring

1. Solder 100uF/100V capacitor and leads to the Audio Transformer (TX290) (see Figure 11).
2. Mount the transformer on the optional equipment plate (CB486) using 2 x M4 bolts as shown in figure 12.
3. Wire the transformer to the main OWS module as shown in the block wiring diagram.



Figure 14 60W Transformer Fitted into Brooks Equipment Plate

4.5.2 Mounting 60W Audio Transformer onto Existing Panel

1. Using figure 15 as a drilling guide, drill two holes for mounting the transformer. If drilling and tapping your fixings, use 3.2mm HSS drill bit & M4 tap. If using nut and bolt for your fixings, use 4.5mm HSS drill bit M4 nuts and bolts
2. Clean and remove all metal filling etc from panel.
3. Mount the 60W transformer as shown in figure 16

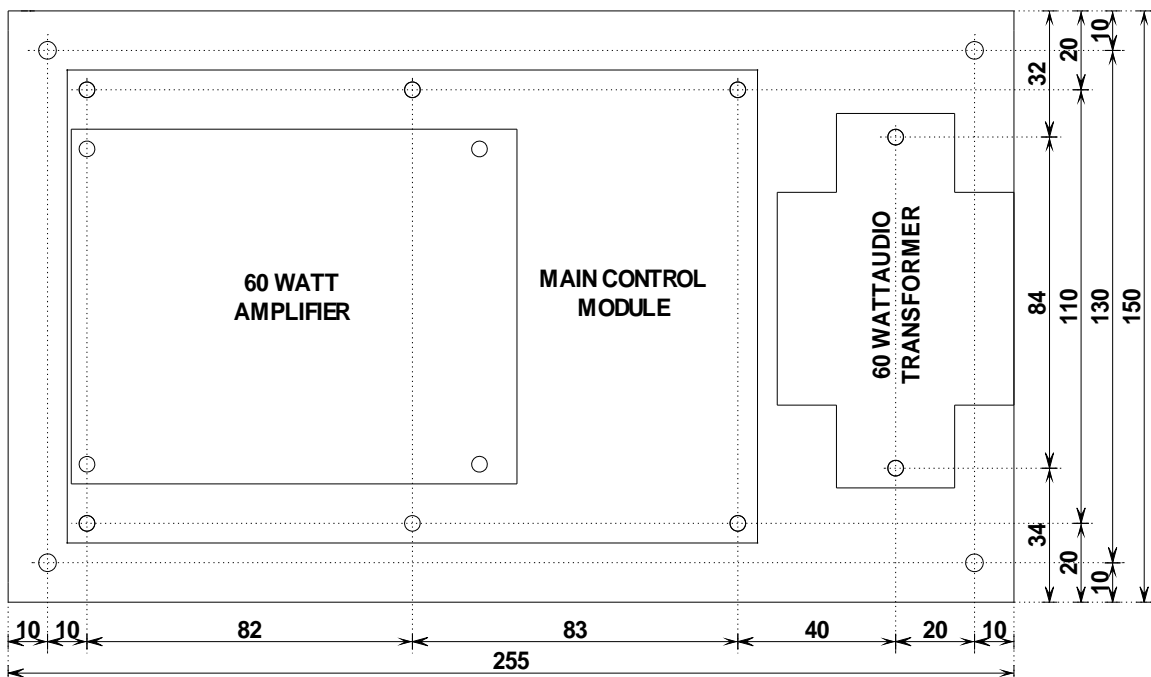

Figure 15 Brooks equipment plate CB586

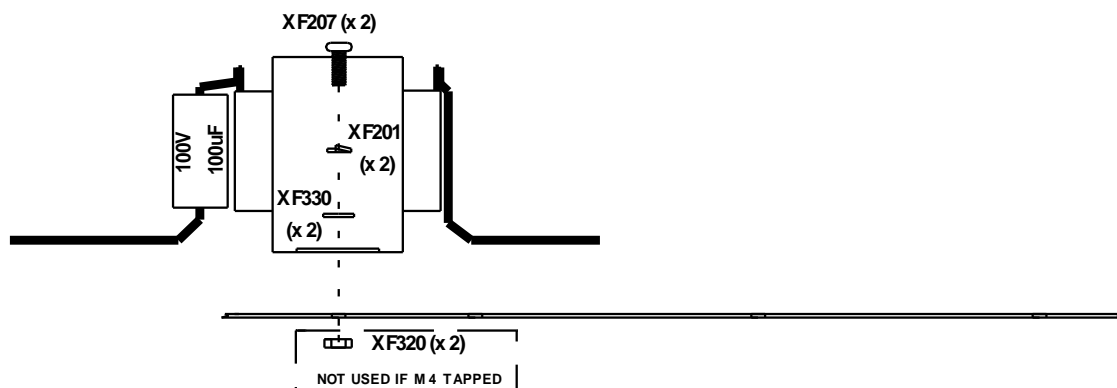

Figure 16 Audio transformer fitted in existing panel

4.6 Audio Transformer Assembly 150 Watt

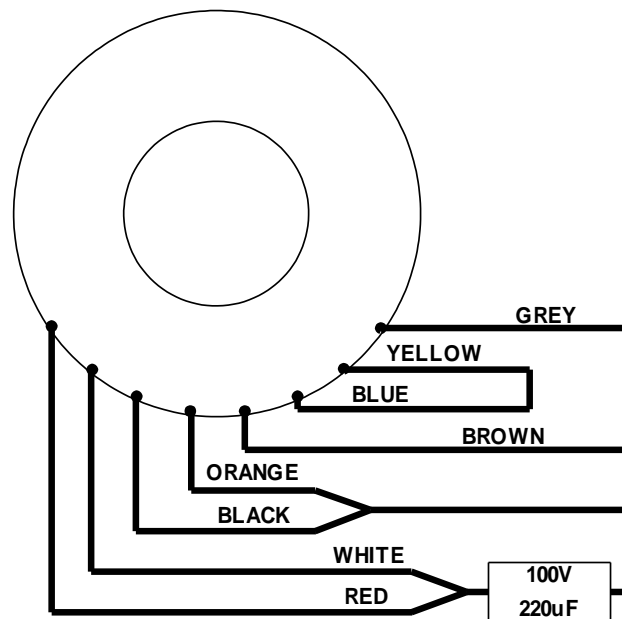

Figure 17 150W/100V Audio transformer wiring

4.6.1 Mounting 150W Audio Transformer onto Optional Brooks Equipment Plate CB486

1. Solder 220uF/100V capacitor and leads to the Audio Transformer (TX300) (see Figure 17).
2. Mount Brooks optional right angle bracket CB487 into Brooks equipment plate CB486
3. Mount the transformer on angle bracket using the hardware supplied with the transformer as shown in Figure 19 on page 26.
4. Wire the transformer to the main OWS module and amplifier as shown in the block wiring diagram.

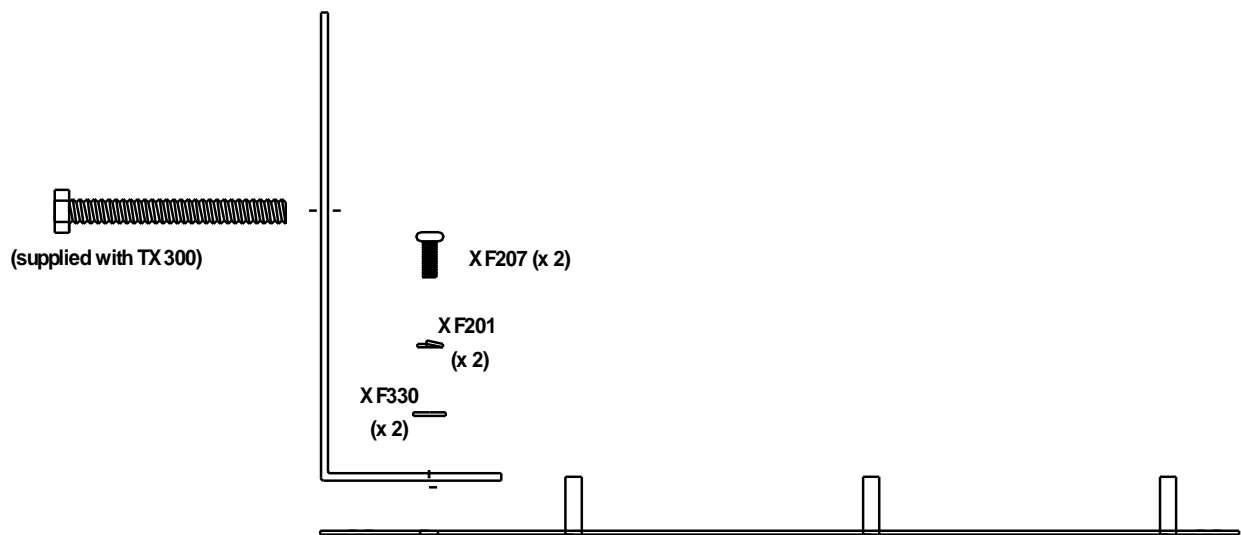

Figure 18 Step 1 fixing mounting bracket onto Brooks equipment plate

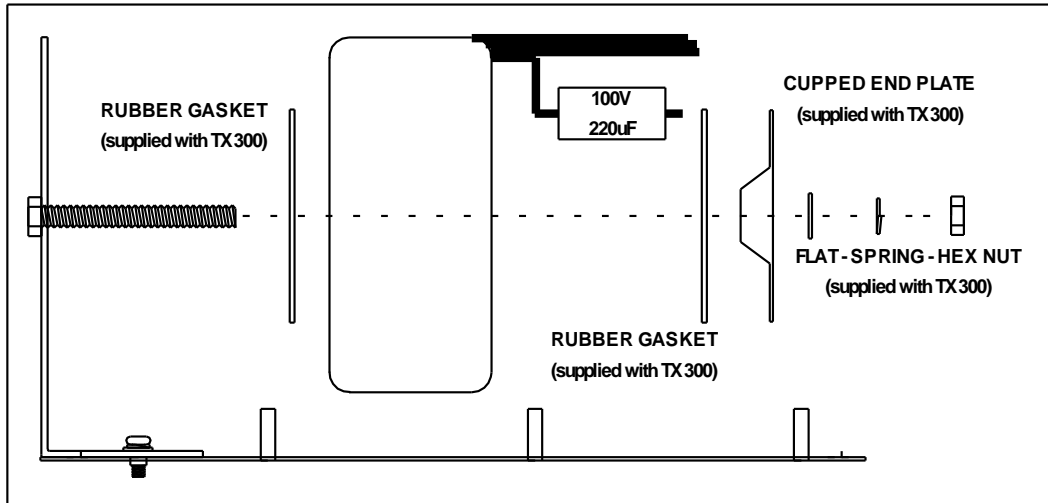

Figure 19 Step 2 mounting 150W audio transformer onto Brooks angle bracket

4.6.2 Mounting 150W Audio Transformer onto Existing Panel

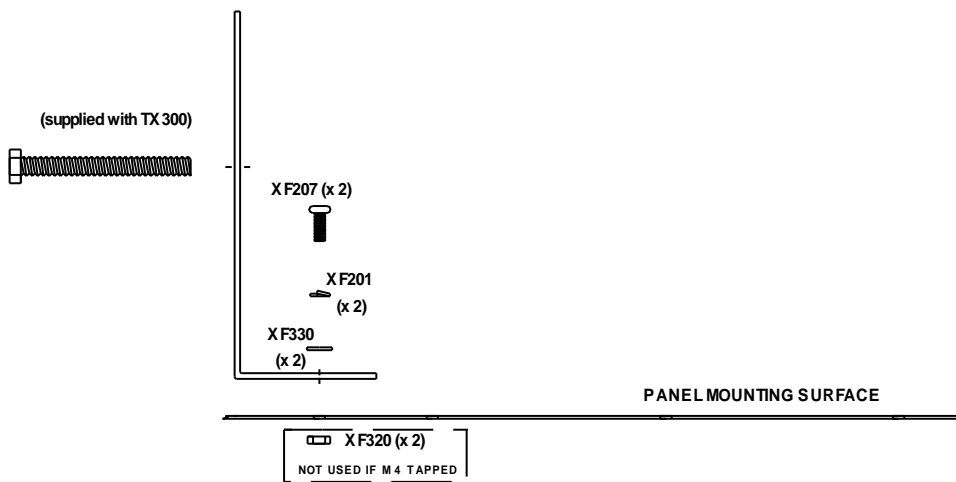

Figure 20 Step 1 fixing mounting bracket onto existing panel

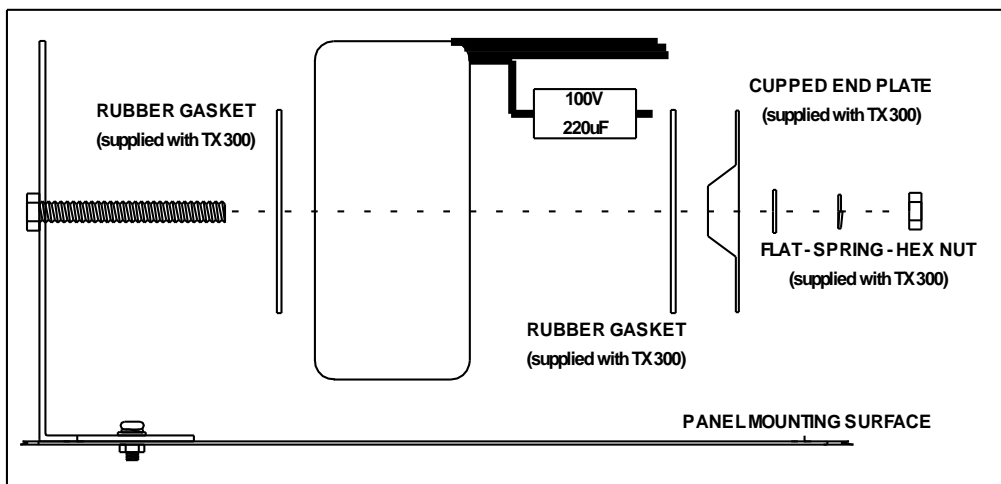

Figure 21 Step 2 mounting 150W transformer onto bracket

4.7 OWS Main Control Module (SUB860) and Amplifier

4.7.1 Mounting Main Control Module and Amplifier onto Brooks Equipment Plate

1. Mount the 60W audio transformer onto Brooks equipment plate as per 4.5.1 on page 23, Figure 13 on page 23 and Figure 14 on page 24.
If 150W transformer is used, refer to section 4.6 on page 25, Figure 20 on page 26 and Figure 21 on page 26.
2. Using Figure 15 on page 24, Fit four M3 x 25mm Hex Spacers (XF040), to holes shown in Figure 15 on the OWS Main Control Module as shown in the following two drawings..

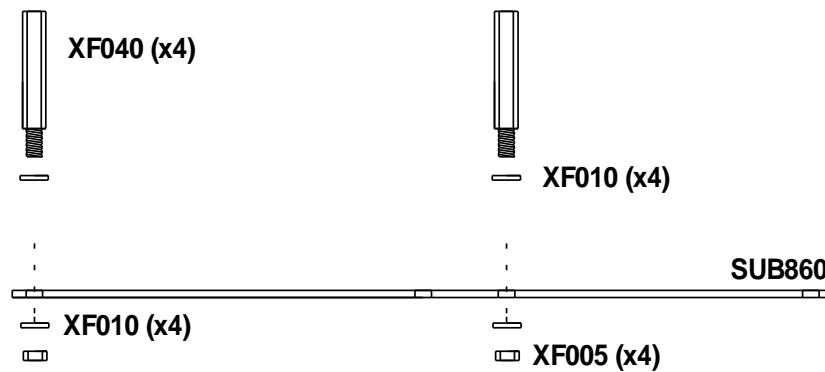

Figure 22 Fixing Spacers Required to Mount the Amplifier on Main Module

3. Mount the main control board SUB860 onto the stand-off provided in Brooks equipment plate

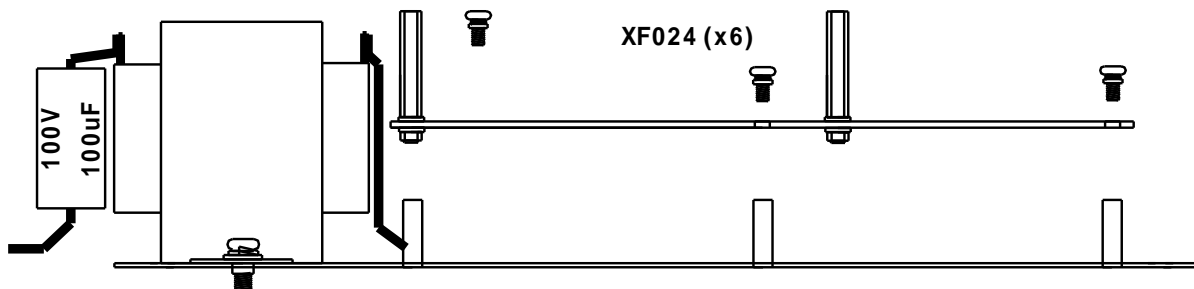

Figure 23 Mounting Main Control Module onto Brooks Equipment Plate

4. Mount Brooks amplifier 60W (SUB865) or 120W (SUB866) as shown in the following two drawings

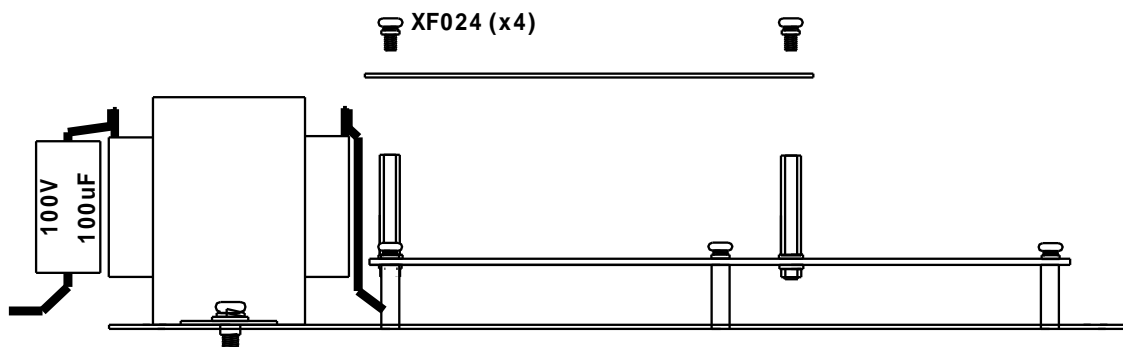

Figure 24 Mounting amplifier module on top of main module

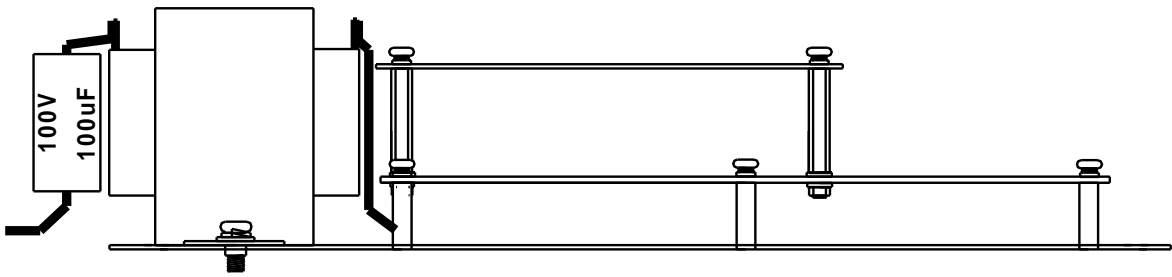

Figure 25 Complete Assembly of Brooks OWS Plate

5. The final assembly of the amplifier and main control module is shown in the following picture

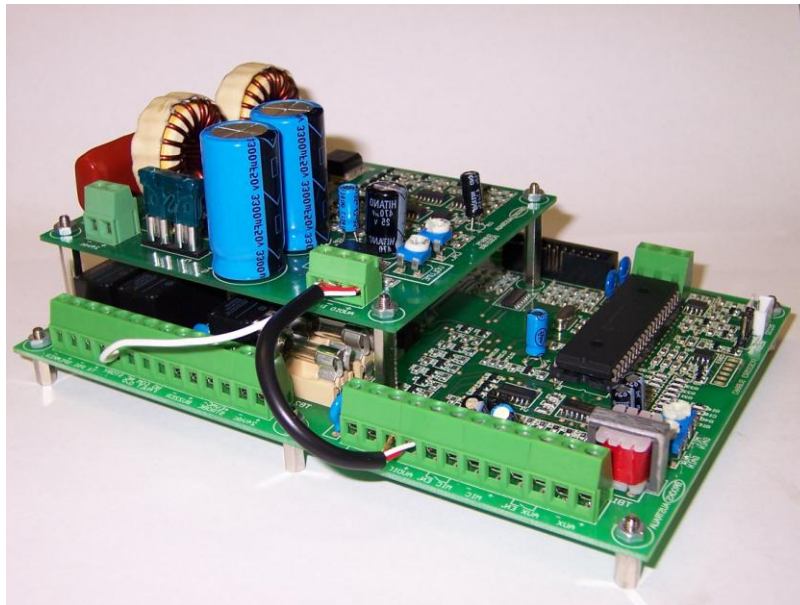
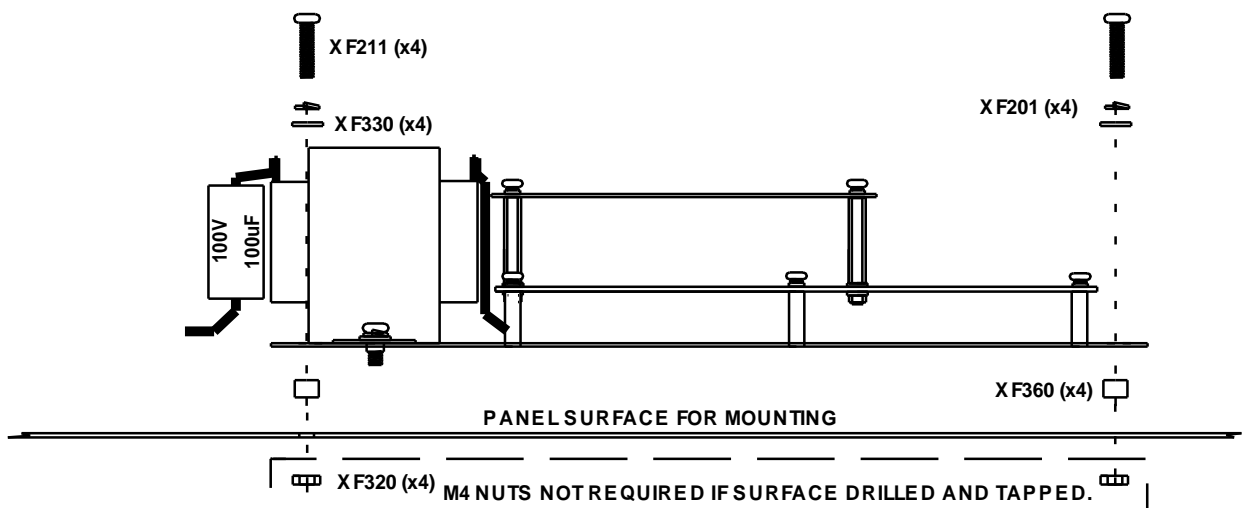

Figure 26 Main Control and Amplifier Modules (Picture)

6. Fit Brooks complete equipment plate to a spot on the panel mounting surface as shown in the following two drawings.



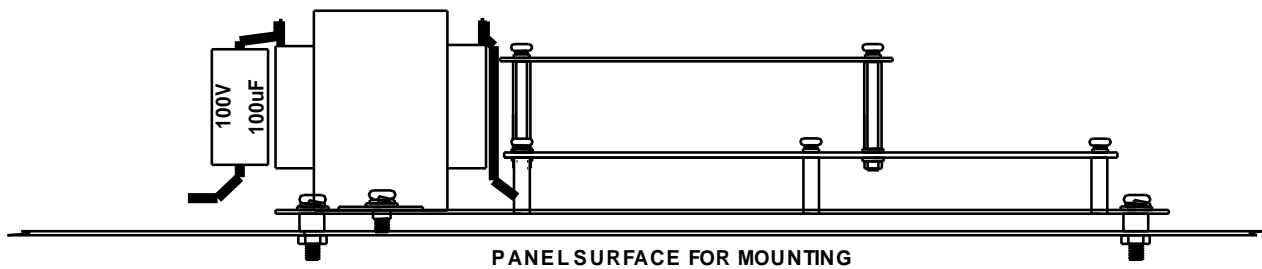

Figure 27 Fixing Brooks Equipment Plate into a panel

4.7.2 Mounting Main Control Module and Amplifier onto Existing Panel

Brooks OWS main control board, transformers and amplifier boards can be mounted on spare spot on the rear of and CIE. It is recommended to use Brooks mounting plates CB485, CB486 and CB487 to ensure ease of installation however, if boards and transformer are required to be mounted inside the CIE without using Brooks metal plates do the following:

1. Mount the display board and decal label as in section 4.4.2 on page 22, Figure 11 on page 22 and Figure 12 on page 23.

Mount The 60W audio transformer as per section 4.5.2 on page 24 and

2. Figure 16 on page 24. For 150W transformer, refer to section 4.6.2 on page 26 Figure 17 on page 25, Figure 20 on page 26 and Figure 21 on page 26
3. Using Figure 15 on page 24 as a guide drill and tap the equipment plate of the CIE to suit the mounting holes for the main control board

Assemble the audio amplifier to the main board as shown in Figure 24 on page 27, Figure 25 on page 28 and in the picture shown in

4. Figure 26 on page 28.

4.8 Final procedures

1. Wire the complete OWS assembly as per the block wiring diagram shown in chapter 5. Internal wiring of the OWS may be pre-wired in the factory on request. Wiring between The OWS and CIE or field wiring must be wired by a qualified technician and according to the relative standard.
2. After mounting the display module on a suitable space in the CIE fascia, affix the OWS decal label, if it has not been affixed. Check the buttons to ensure it operates correctly. When Brooks face plate is used, the decal will be affixed at the factory.
3. Affix the warning sticker "Caution 100V Audio Line"
4. Test the OWS as per the OWS technical manual.

5 WIRING OF BROOKS OWS

The Brooks OWS shall be wired as per the following block wiring diagram:

1. 60W OWS
Figure 28 Wiring Diagram for Stand Alone 60W OWS
2. 120W OWS
Figure 29 Wiring Diagram for Standalone 120W OWS
3. 4 Zone expansion board
Figure 31 Wiring Diagram for 4 Zone Split Module & PA Selection
4. 250W OWS
Figure 30 Wiring Diagram for Optional Stand Alone 250W OWS

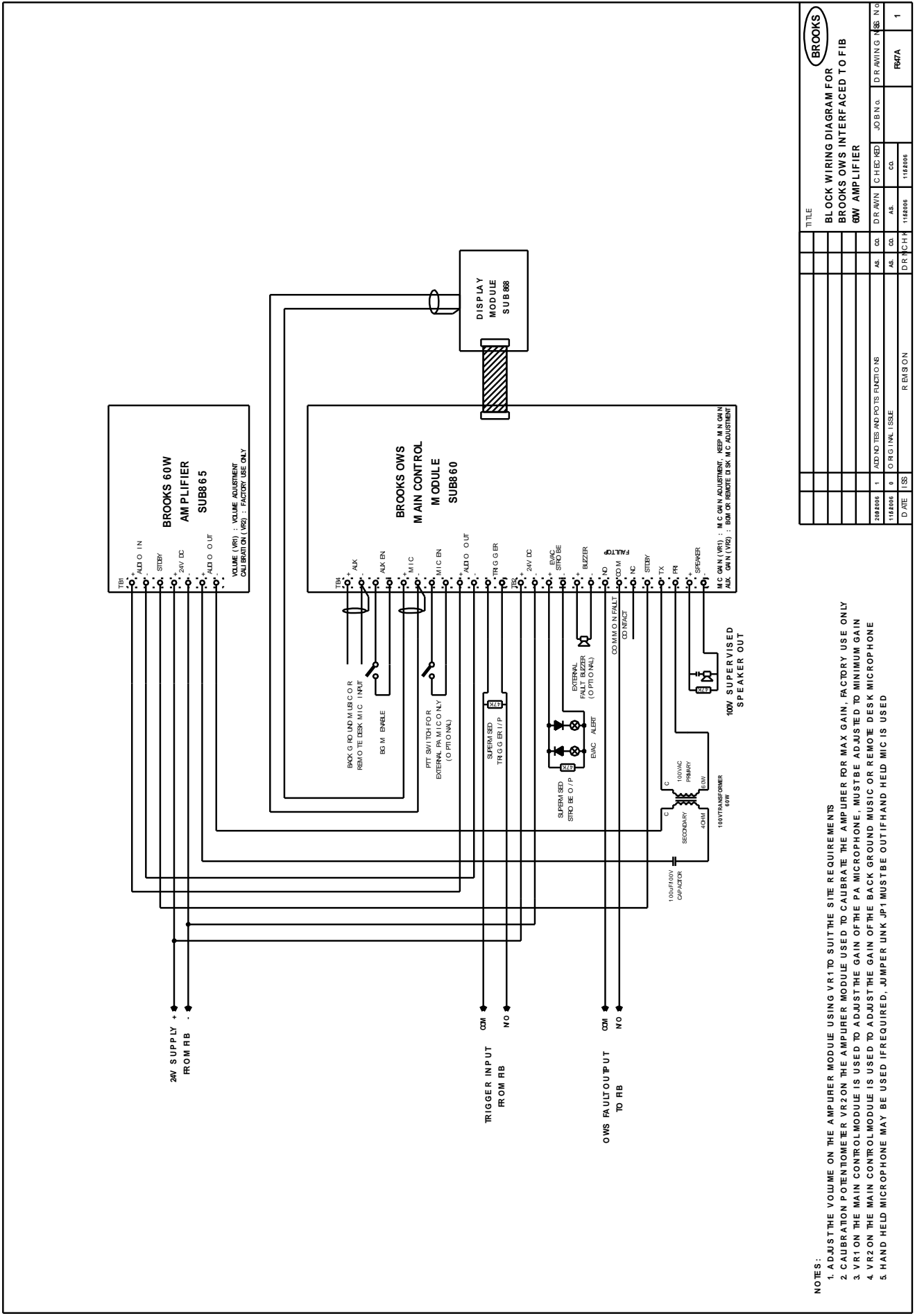

TITLE		D R W N		C H E C K E D		J O B N U M		D R W N I N G N U M	
BROOKS									
BLOCK WIRING DIAGRAM FOR									
BROOKS OWS INTERFACED TO FIB									
60W AMPLIFIER									
200806	1	ADD NOTES AND POINTS TO FACTORY	AS	CO	D R W N	C H E C K E D	J O B N U M	D R W N I N G N U M	ISS
1168006	0	FOR FINAL ISSUE	AS	CO	AS	CO		1168006	1
D A T E	ISS	REVISION	D R W N	C H E C K E D	1168006	1168006			R667A

- NOTES :
1. ADJUST THE VOLUME ON THE AMPLIFIER MODULE USING VR1 TO SUIT THE SITE REQUIREMENTS
 2. CALIBRATION POTENTIOMETER VR2 ON THE AMPLIFIER MODULE USED TO CALIBRATE THE AMPLIFIER FOR MAX GAIN, FACTORY USE ONLY
 3. VR1 ON THE MAIN CONTROL MODULE IS USED TO ADJUST THE GAIN OF THE PA MICROPHONE, MUST BE ADJUSTED TO MINIMUM GAIN
 4. VR2 ON THE MAIN CONTROL MODULE IS USED TO ADJUST THE GAIN OF THE BACK GROUND MUSIC OR REMOTE DESK MICROPHONE
 5. HAND HELD MICROPHONE MAY BE USED IF REQUIRED, JUMPER LINK JP1 MUST BE OUTFITTED IF HAND HELD MIC IS USED

Figure 28 Wiring Diagram for Stand Alone 60W OWS

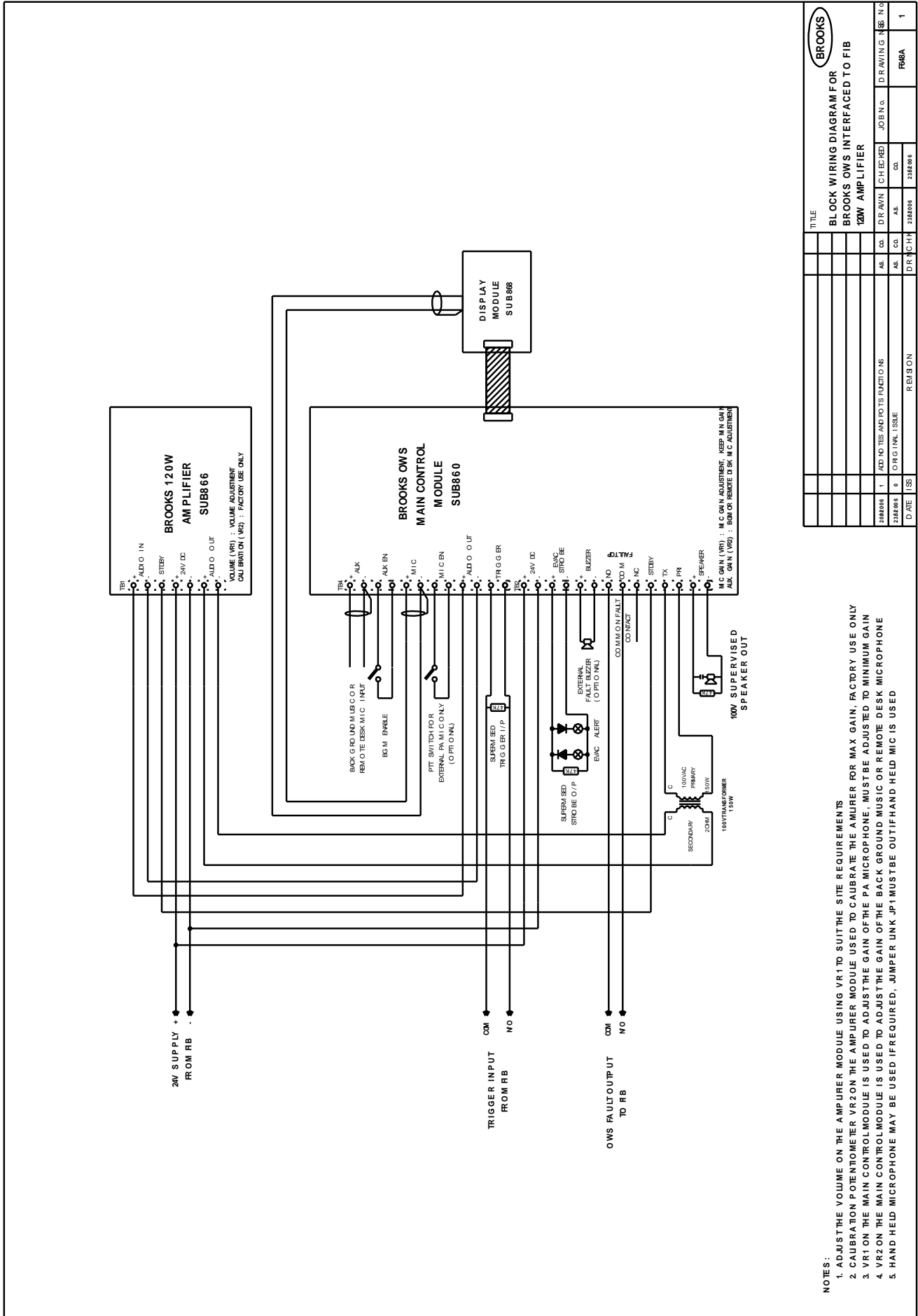

TITLE		JOB NO.		ISS. NO.	
BLOCK WIRING DIAGRAM FOR BROOKS OWS INTERFACED TO FIB 120W AMPLIFIER					
AS.	CO.	DR. AVN	CH. ECR	DR. AVN	ISS. NO.
236E006	1	ADD NOTES AND POINTS FACTORS			
236E006	0	ORIG. INK. ISSUE			
DATE	ISS.	REVISION	DR. CHH	236E006	236E006
					1

Figure 29 Wiring Diagram for Standalone 120W OWS

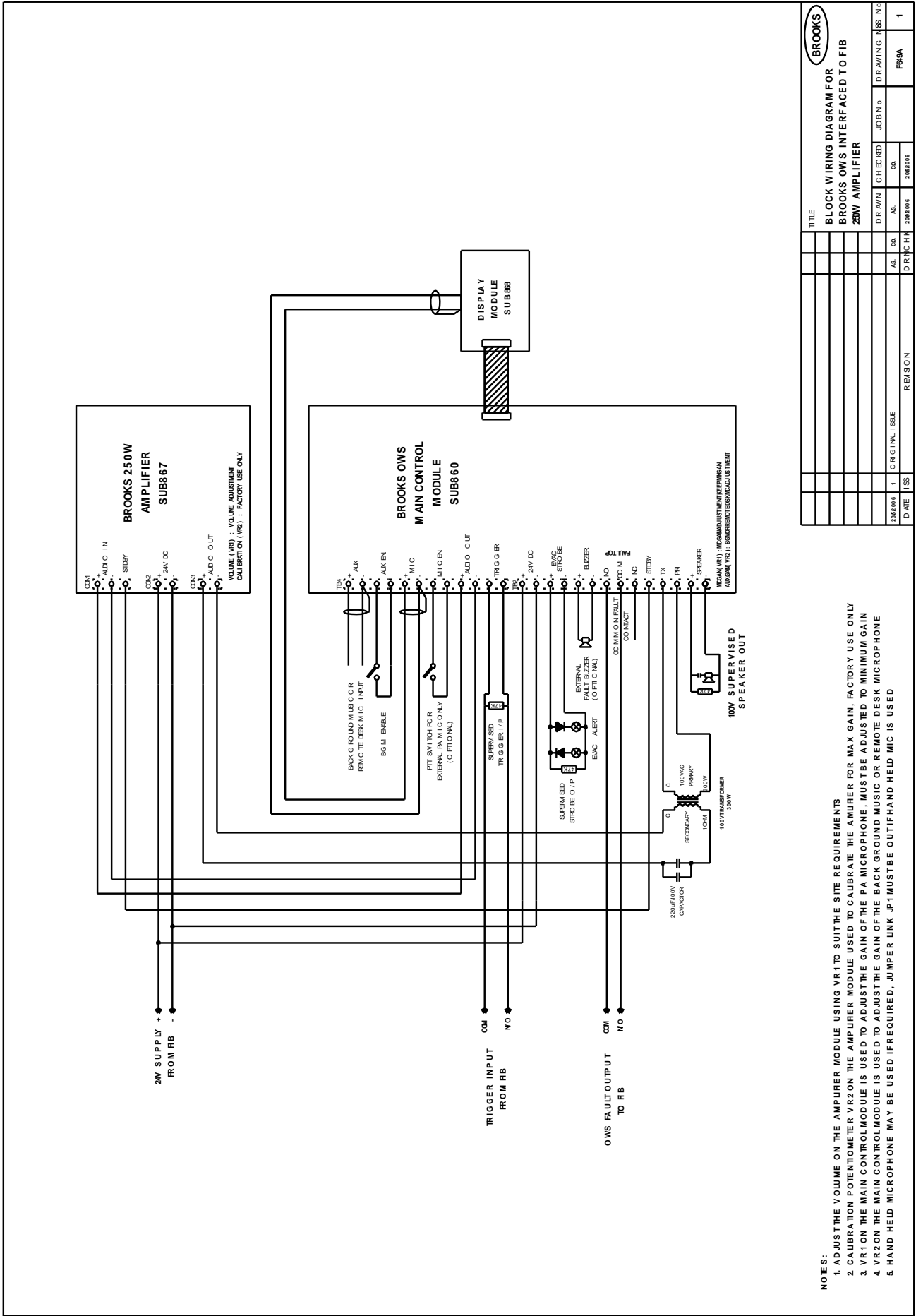

BROOKS		TITLE	
BLOCK WIRING DIAGRAM FOR			
BROOKS OWS INTERFACED TO FIB			
250W AMPLIFIER			
2388004	1	OR ORIGINAL ISSUE	2008/006
DATE	ISS	REVISION	DRAWING
			1

Figure 30 Wiring Diagram for Optional Stand Alone 250W OWS

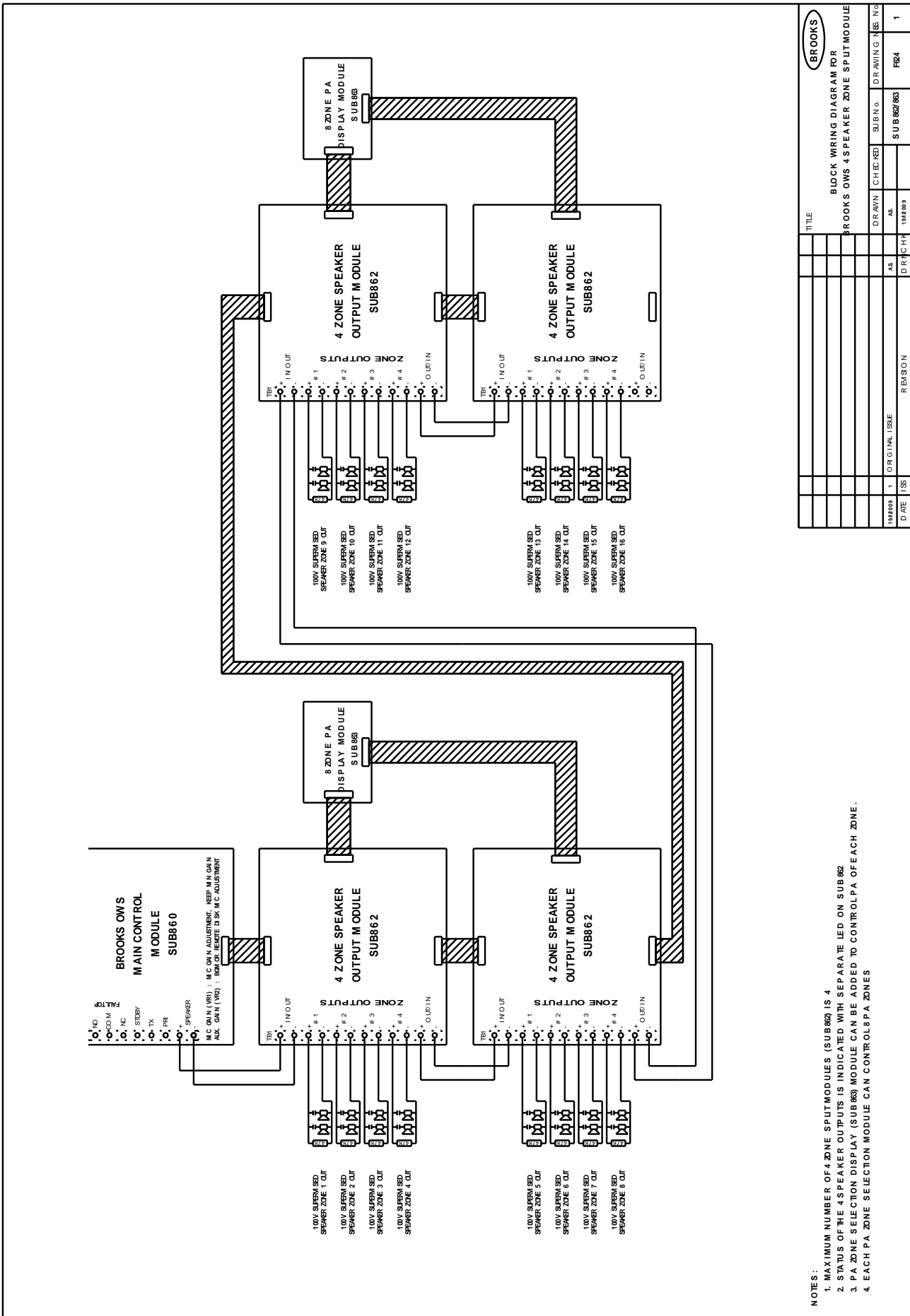

Figure 31 Wiring Diagram for 4 Zone Split Module & PA Selection

NSW

4 Pike Street Rydalmere NSW 2116

Ph: 02 9684 1466

Fax: 02 9684 4146

Website www.brooks.com.au

VIC

1/3 Molan Street, Ringwood, VIC 3134

Ph: 03 9879 5294

Fax: 03 9879 5249

SA

729A Port Road, Woodville, SA 5011

Ph: 08 8347 0000

Fax: 08 8347 0600

QLD

2/49 Boyland Ave Coopers Plains, QLD 4108

Ph: 07 3373 8222

Fax: 07 3373 8022

OR NATIONAL SALES NUMBER: 1300 78 FIRE

FOR THE COST OF A LOCAL CALL

