

SPKSM200-5 | 200mm 100V 5W Surface Mount Speaker White AS ISO7240.24

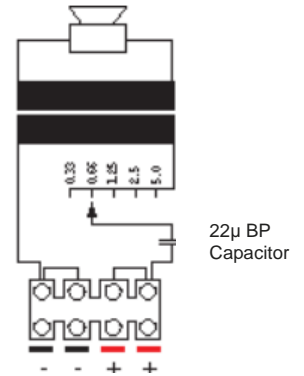
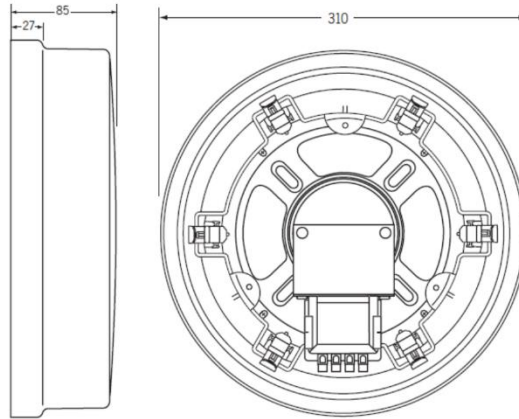

Designed to meet the requirements of AS ISO7240.24:2015 the SPKSM200-5 features flame retardant housing material and a tuned PA driver to suit the new approval requirements. One-Shot design simply snap-fits in seconds to the surface mounting ring, reducing installation time considerably.

Features

- Designed to meet AS ISO7240.24 standard for fire & evacuation warning systems
- High power 5 Watt output for increased SPL
- Excellent speech intelligibility
- High quality speaker driver developed for BGM, paging and emergency warning applications
- Fitted with 4 way wire protect terminal block for loop in, loop out wiring as required by Australian Standards.
- Fitted with supervisory capacitor for line monitoring

Technical Specification

Power Taps	.33W, .66W, 1.25W, 2.5W, 5W
Sensitivity	93dB (1W @ 1m) 81dB (1W @ 4m)
Max Sound Pressure Level	101dB (5W @ 1m) 89dB (5W @ 4m)
Frequency Response	100Hz - 15kHz, 500-4kHz: 0 ± 8dB
Coverage Angle (-6dB)	500Hz: > 180°, 1000Hz: 81° 2000Hz: 93°, 4000Hz: 58°
Environmental Type	(for indoor applications as per standard)
Speaker Component	200mm (4") paper cone speaker
Mounting Method	Surface Attachment
Line Monitoring	Yes, 22µF bipolar capacitor
Applicable Cable	2.5mm ² (14AWG) max conductor area
Finish	White flame retardant ABS grille and housing (Taitalac 8540T) Clear Flame retardant ABS spring clips (Makrolon 6557)
IP Rating	IP21C
Dimensions	310Ø x 85mm
Weight	1.36Kg

Compliance

Designed to meet AS ISO7240.24:2015, 'Fire Detection and alarm systems – Part 24: Sound-system loudspeakers