

EIB428RF - RadioLINK Relay Module

Mains Powered 230V~ Rechargeable Battery Back-up

Key Features

- Designed for standalone or use with Easi-fit 140RC series of alarms
- RF wireless interconnect
- Unique house coding feature
- Visual RF transmission indicator
- Advanced suppression and calibration technology
- Radio transmitter and receiver in each base
- Easi-fit design construction
- Non-removable, rechargeable lithium battery back-up
- 5 Year Guarantee (limited)

Product Description

The EIB428RF Relay Base is a device that switches a relay upon receipt of an alarm signal from a suitable alarm.

The EIB428RF relay base is primarily designed to work with the range of RadioLINK products, but for additional flexibility it can also be used with conventional hard wired interconnect systems.

The EIB428RF Relay Base is powered by 230VAC mains and has rechargeable battery backup (in the event of a mains failure). As supplied, the relay operates continuously but can be easily adjusted to pulse condition.

The electrically isolated contacts can be used for many applications such as signalling, turning on lights, strobes etc.

The EIB428RF uses advanced radio transceiver technology with unique software coding to transmit and receive the radio signals. The transmissions are frequency modulated (FM) and use Manchester coding to ensure robust signal integrity and avoid signal noise interference.

The EIB428RF has built in circuitry to aid suppression of voltage transients and RF interference.



Technical Specification

Supply Voltage:	230V AC 40 mA
Battery back-up:	Rechargeable Lithium Battery
RF Visual Indicator:	Red LED flashes on receipt of an RF signal
RF Frequency:	926.365 MHZ (1% duty cycle)
RF Power:	+5dBm
Relay Contacts:	250 Volt AC - 5A Resistive
Normal Operating and Storage Temperature:	Range 0°C to 40°C
Normal Operating and Storage Humidity Range:	15 % to 95 % Relative Humidity (Non-condensing)
Fixing:	Screw fixings supplied
Power-on Indicator:	Green LED
Interconnect:	Up to 12 RadioLINK devices
Plastic material:	UL94VO flame retardant
Dimensions:	141mm x 26mm
Weight:	180g
Warranty:	5 year (limited) warranty
Approvals:	AS/NZS 4268

Due to continual product development, Brooks reserve the right to alter product details and specifications without prior notice.

Head Office: Sydney, 4 Pike Street, Rydalmere 2116 | PO Box 7050 Silverwater BC1811
Regional Offices: Melbourne - Brisbane - Adelaide - Perth - Auckland
www.brooks.com.au - Toll Free 1300 783 473

EIB428RF - RadioLINK Relay Module

EIB428RF - RadioLINK Relay Module

Operation

- ▶ The green indicator will illuminate to show mains power is present.
- ▶ In "continuous" mode, the relay will switch until an alarm cancel signal is received.
- ▶ In "Pulse" mode, the relay will switch for 5 seconds only and return to standby state.
- ▶ In code mode, the red indicator will flash to indicate the number of other RF alarms that have been "learned" in the system.
- ▶ The red indicator on the alarm attached to the EIB168 Base will flash rapidly to show an alarm condition for the smoke detector.
- ▶ The red light every 10 seconds to indicate that the battery back-up is depleted (green light switches off).

EIB428RF - RadioLINK Relay Module

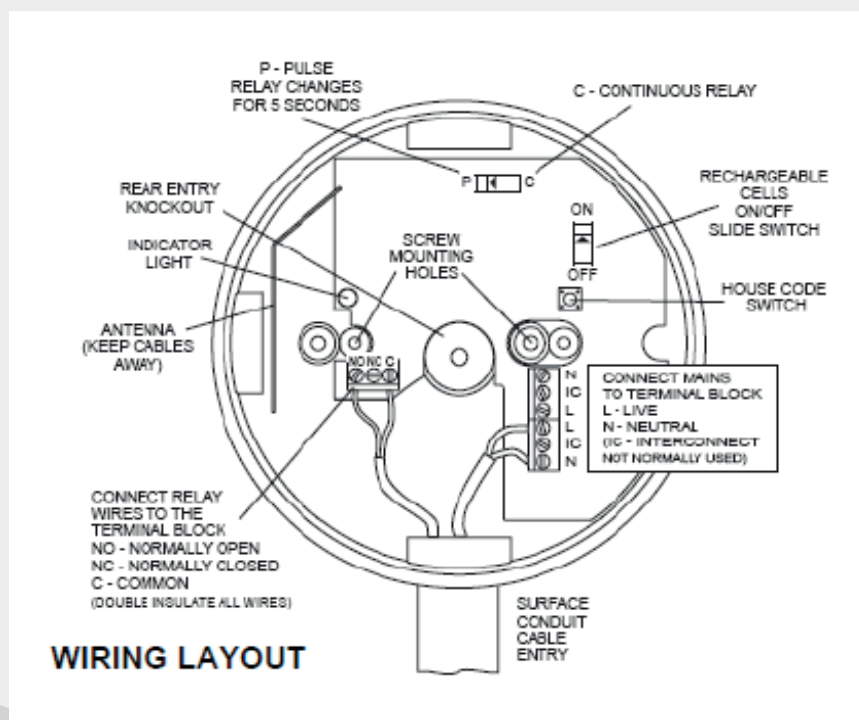

Due to continual product development, Brooks reserve the right to alter product details and specifications without prior notice.

Head Office: Sydney, 4 Pike Street, Rydalmere 2116 | PO Box 7050 Silverwater BC1811
Regional Offices: Melbourne - Brisbane - Adelaide - Perth - Auckland
www.brooks.com.au - Toll Free 1300 783 473